

REVISION HISTORY			
REV	DESCRIPTION	DATE	APPROVED
1	DCR #2009-273	8/10/2009	ggravelle

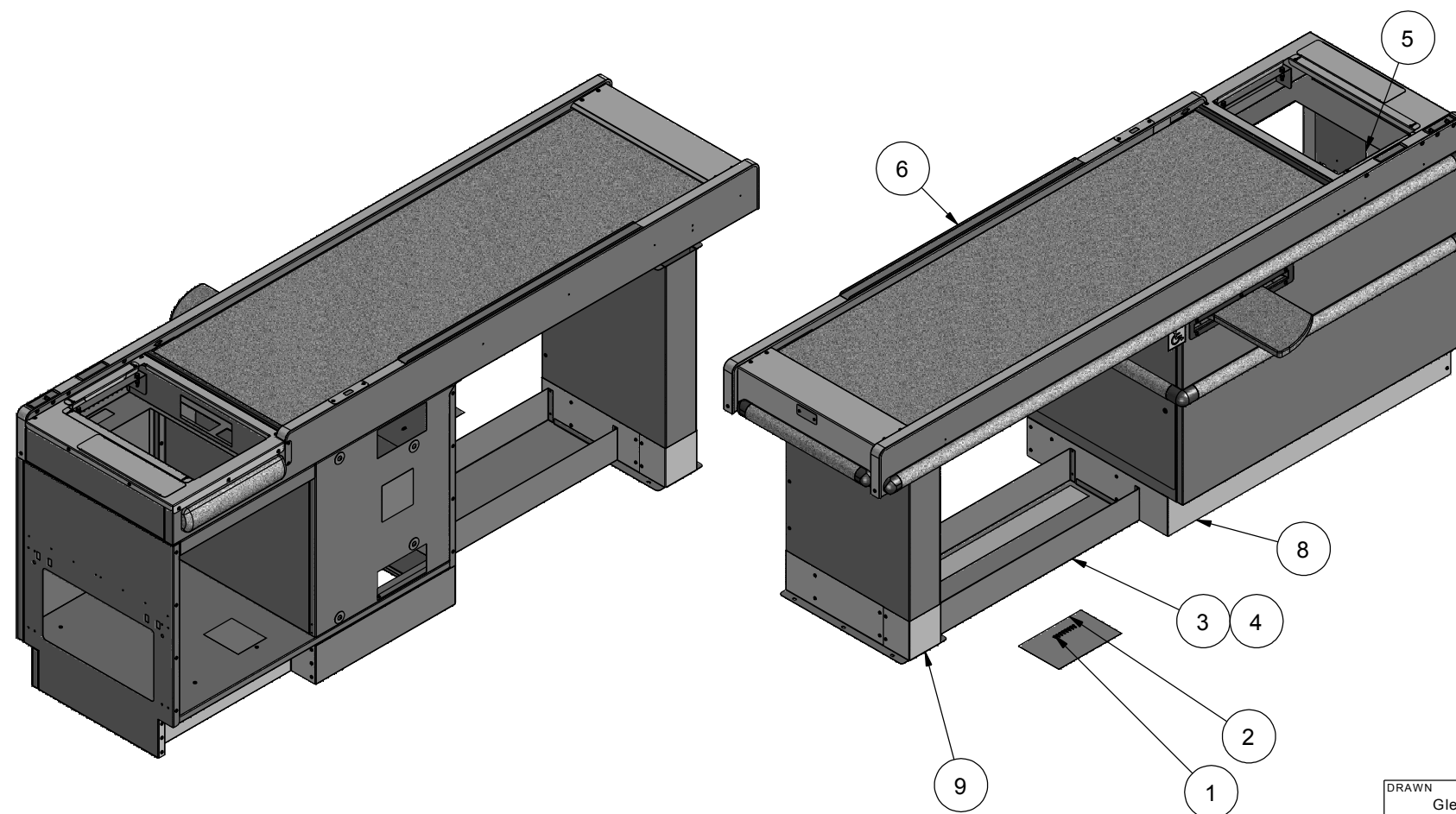
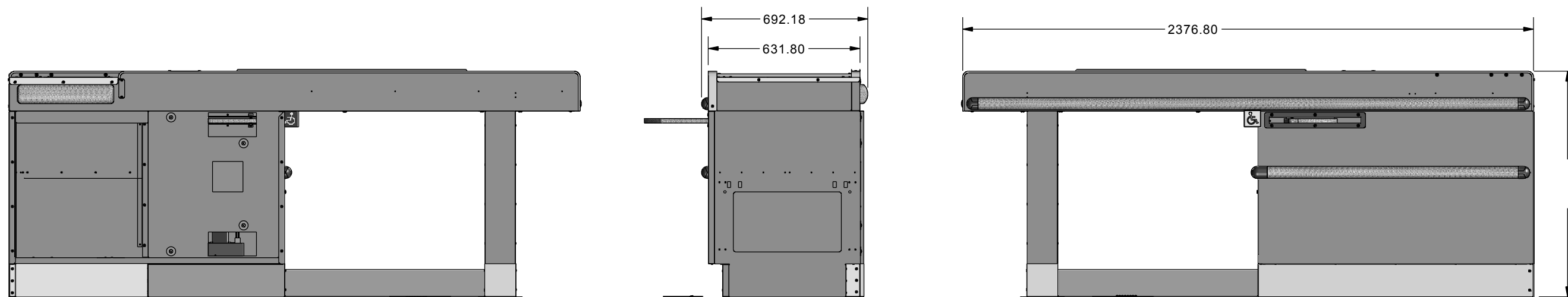

Parts List			
ITEM	PART NUMBE	QTY	DESCRIPTION
1	23222	12	#8 x 1/2" SELF DRILL SCREW
2	4372	1	PACKING SLIP, 6.5" x 10"
3	500380	1	Shipping Brace
4	64764	1	LABEL, REMOVE BRACE
5	902	1	Label, "Level Conveyor"
6	BM-56317-LH	1	Assy, 8' LH Conveyor
8	BM-56482-LH	1	BASE CABINET ASS'Y for CONVEYOR LANE
9	BM-62317	1	CONVEYOR PEDESTAL ASSEMBLY

DRAWN Glen Shirley	6/17/2009	ALL DIMENSIONS ARE IN MILLIMETERS, ANSI Y14.5 ST. STL. PARTS PAPERSIDE UP UNLESS OTHERWISE NOTED	FIRST ANGLE PROJ
CHECKED		DESCRIPTION: Assy, 8' Conveyor -LH	REV 1
OPPOSITE DWG		MATERIAL	DWG NO BM-56478-8-LH
REFERENCE DWG		TITLE: SHEET 1 OF 1	
PAINT ZONE	Pan-Oston		

The contents of this drawing are the exclusive property of Pan-Oston, and are for the use of the customer for whom they were created. Any reproduction or disclosure thereof without the written consent of Pan-Oston, is strictly prohibited.