

INSTALLATION, OPERATION & MAINTENANCE MANUAL

Versymmetric™ Two Post Surface Mounted Lift

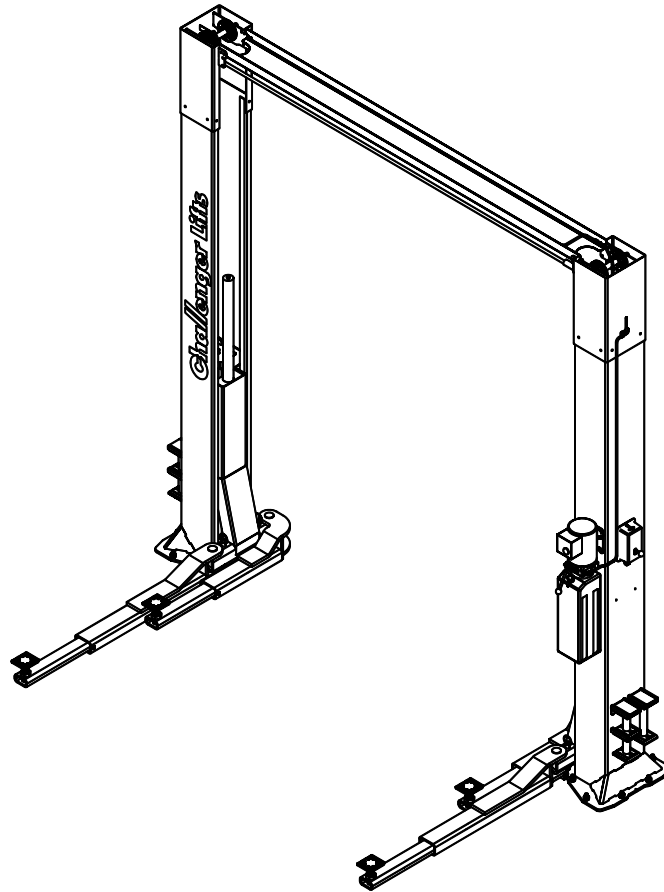

MODEL CL10

10,000 LBS. CAPACITY
2500 LBS. PER ARM

200 Cabel Street, P.O. Box 3944 Louisville, Kentucky 40201-3944
Email: sales@challengerlifts.com Web site: www.challengerlifts.com

Office 800-648-5438 / 502-625-0700 Fax 502-587-1933

IMPORTANT: READ THIS MANUAL COMPLETELY BEFORE
INSTALLING or OPERATING LIFT

GENERAL SPECIFICATIONS

See Figure 1	CL10	CL10-2	CL10-3
A Column Height	11'- 8"	13'- 8"	14'- 8"
B Floor to Overhead Switch	11'- 2 1/2 "	13'- 2 1/2"	14'- 2 1/2"
C Rise Height (<i>Screw Pads Highest Position</i>)	74 5/8"		
D Cylinder Height (<i>Full Stroke</i>)	11'- 11"		
E Adjustable Overall Width	11'- 11" / 11' - 6 1/2"		
F crew Pad Height	4 1/8" to 6 5/8"		
G Inside of Columns	114 1/2" / 110"		
Drive Thru Clearance	104 1/2" / 100"		
Ceiling Height Required	11'- 11 "	13'- 9"	14'- 9"
* Maximum Capacity	10,000 lbs. (2500 lbs. Per Arm)		
Lifting Time	48 Sec. (approximate)		
Motor	2HP, Single Phase, 60Hz, 208/230 Optional - 2HP, Three Phase, 50/60Hz, for 208 or 230 or 460		

* Lift capacity ratings are based on loads equally distributed on all four arms.

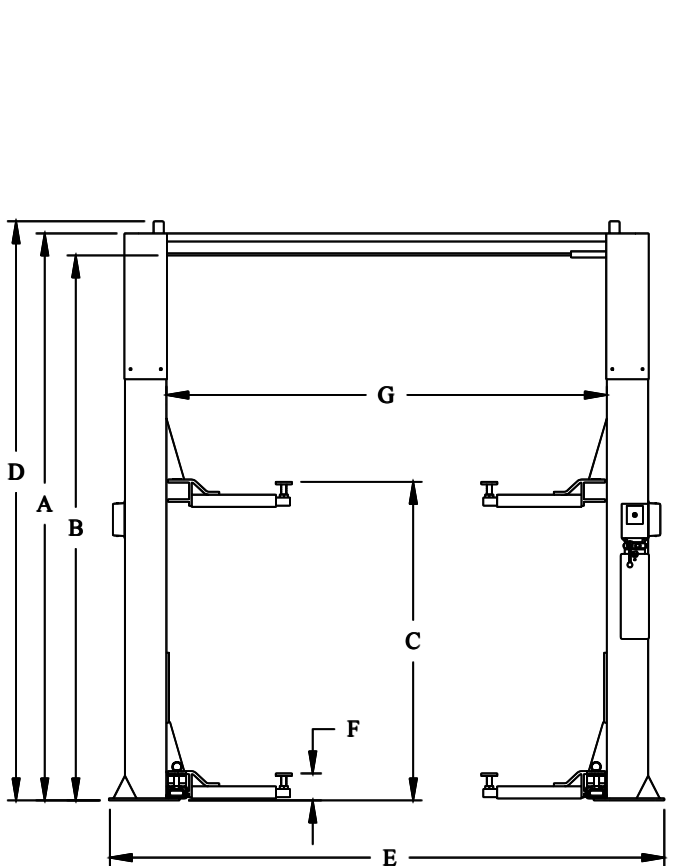

Fig 1a - General Specifications

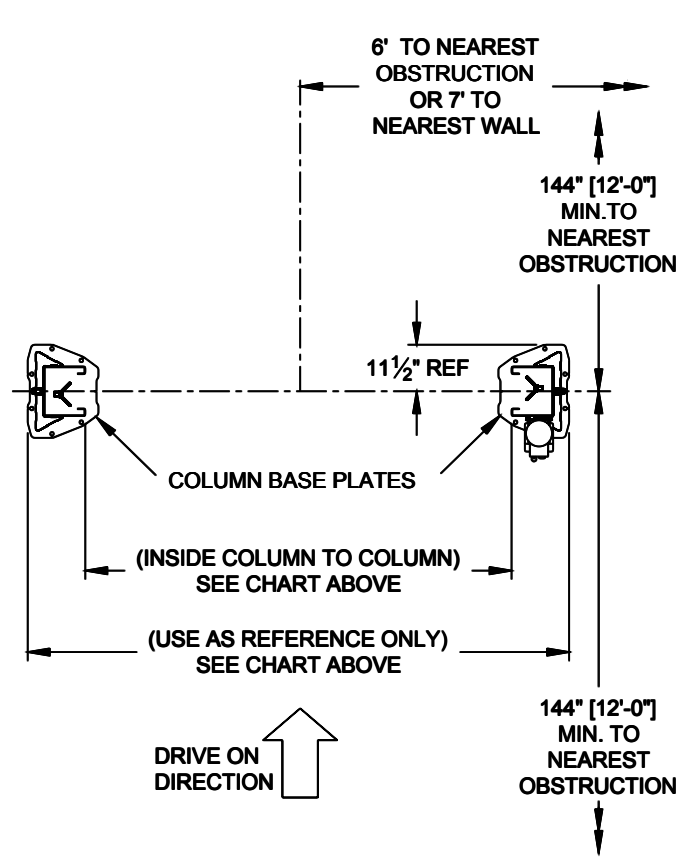

Fig 1b - Service Bay Layout

VERTICAL CLEARANCE

Check the height of the area where the lift is to be installed. Clearance should be calculated based on the full raised height of the lift.



Failure by purchaser to provide adequate clearance could result in unsatisfactory lift performance, property damage, or personal injury.

FLOORING

Be certain you have the proper concrete floor to properly handle the loaded lift. Floor should be in generally good condition with no large cracks, spalling or deterioration.

Minimum requirements for concrete are 4 inches minimum depth, with steel reinforcement, 3500 psi, cured for 28 days per local commercial practice. Floor should be level within 3/8 inch over the installation area. No anchors should be installed within 8 inches of any crack, edge, or expansion joint. If these conditions cannot be met, a pad may be poured to accommodate the lift.

Check with local building inspectors and/or permits office for any special instructions or approvals required for your installation.



Failure by purchaser to provide the recommended mounting surface could result in unsatisfactory lift performance, property damage, or personal injury.

ELECTRICAL REQUIREMENTS

For lift installation and operation for single phase units, it is necessary to have a dedicated circuit with a double pole 25 amp circuit breaker or time delay fuse.

SAFETY NOTICES AND DECALS

For your safety, and the safety of others, read and understand all of the safety notices and decals included here.

READ ENTIRE MANUAL BEFORE ASSEMBLING, INSTALLING, OPERATING, OR SERVICING THIS EQUIPMENT.

**PROPER MAINTENANCE AND INSPECTION IS NECESSARY FOR SAFE OPERATION.
DO NOT OPERATE A DAMAGED LIFT.**

Safety decals similar to those shown here are found on a properly installed lift. Be sure that all safety decals have been correctly installed on the Power Unit reservoir. Verify that all authorized operators know the location of these decals and fully understand their meaning. Replace worn, faded, or damaged decals promptly.



Do not attempt to raise a vehicle on the lift until the lift has been correctly installed and adjusted as described in this manual.

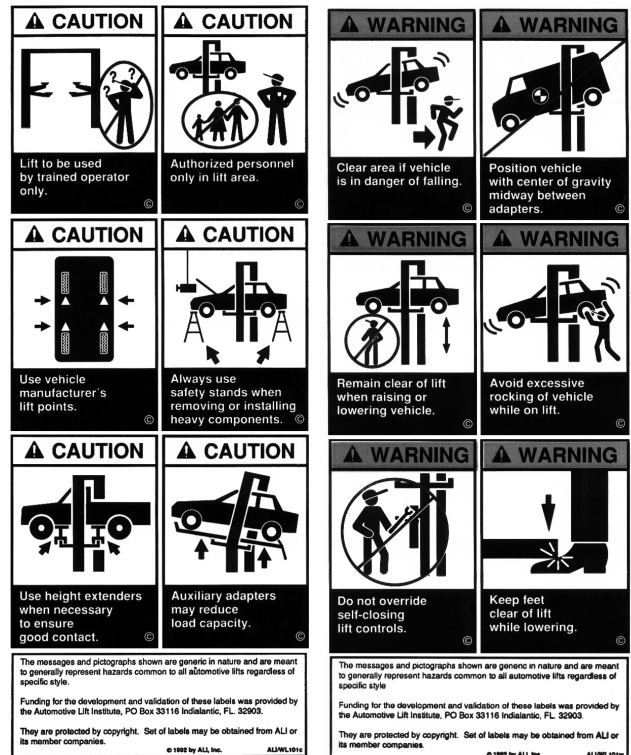

RECEIVING

The shipment should be thoroughly inspected as soon as it is received. The signed bill of lading is acknowledgement by the carrier of receipt in good condition of shipment covered by our invoice.

If any of the goods called for on this bill of lading are shorted or damaged, do not accept them until the carrier makes a notation on the freight bill of the shorted or damaged goods. Do this for your own protection.

NOTIFY **Challenger Lifts** AT ONCE if any hidden loss or damage is discovered after receipt.

IT IS DIFFICULT TO COLLECT FOR LOSS OR DAMAGE AFTER YOU HAVE GIVEN THE CARRIER A CLEAR RECEIPT.

File your claim with **Challenger Lifts** promptly. Support your claim with copies of the bill of lading, freight bill, and photographs, if available.

Component Packing List

PART #	QTY/ LIFT	DESCRIPTION
A2001-P	1	Power Column Ass'y
A2001-I	1	Idler Column Ass'y
A2060	1	Overhead Beam
A2005H	1	Hardware Box
B2002	1	Arm Pack
A2055-0	2	Column Extension for CL10
A2055-1		Column Extension for CL10-1
A2055-2		Column Extension for CL10-2
A2003-0	1	Sync Cable Pack for CL10
A2003-1		Sync Cable Pack for CL10-1
A2003-2		Sync Cable Pack for CL10-2
A2055 - *	2	Column Extensions
A2003 - *	1	Sync Cable Pack
36035	1	Overhead Shut-Off Bar Ass'y
36027	1	Mercury Switch
A1201-17 A1203-17	1	Power Unit – 1 Phase Power Unit – 3 Phase
A2150	1	Literature Pack

INSTALLATION

IMPORTANT: Always wear safety glasses while installing lift.

TOOLS (MINIMUM REQUIRED)

- Tape measure, 16ft
- Chalk line
- 4ft level
- 10" adjustable wrench
- Standard open end wrenches 7/16", 1/2", (2) 9/16", (2) 11/16", 3/4", 15/16"
- 5/16" allen wrench
- Needle nose pliers
- Hammer drill with 3/4" diameter carbide tipped bits
- 2lb hammer
- Torque wrench: 150 foot pounds minimum with 1 1/8" socket
- 12 ft. Step ladder
- Anti-Seize lubricant (for arm pins)

LAYOUT

- Layout the service bay according to the architect's plans or owners instructions (**see Fig 1b**). **Failure to install in this orientation can result in personal and property damage.** Be certain that the proper conditions exist, see page 3.
- Assemble column extension to column using 3/8-16 x 3/4" lg Hex flange head bolt. repeat for opposite column and extension.
- Erect both column assemblies. Align the notches in column base, **Fig 2**, with the installation lines.

ANCHORING

- The anchor bolts must be installed at least 8" from any crack, edge, or expansion joint.
- Use a concrete hammer drill with a 3/4 inch carbide bit. Tip diameter should conform to ANSI Standard B94.12-1977 (.775 to .787). Do not use excessively worn bits or bits which have been incorrectly sharpened. A core bit may be necessary if an obstruction is encountered. **Never substitute with shorter anchor.**
- Recheck "Inside of Columns" dimension, **Fig 1**. Drill the anchor holes using the base plate as a template. Drill through the floor if possible or to a depth of 5 inches minimum.
- Vacuum dust from the hole for proper holding power.
- Shim both columns to plumb using the shims provided as shown in **Fig 2**. **DO NOT** shim more than 1/2" at any given point. Use a level no less than 24" in length to plumb columns.

- 9) Assemble washer and nut to anchor with nut just below impact section of bolt. Drive anchor into hole until nut and washer contact base.

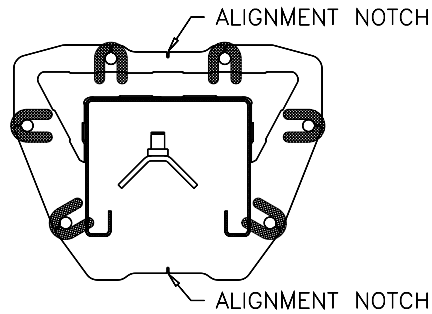

Fig 2 – Column Shimming

- 10) Tighten power column anchors and recheck column for plumb. Reshim if necessary. Torque to 150 foot pounds to set anchors.

OVERHEAD

- 11) Before raising overhead into position install 4 each (2 per column) hex flange bolts and nuts in middle hole of column extension (see **Fig 3 Installation Aid**) for temporary support of overhead. Lift overhead assembly up into position and install with 8 each (4 per column) 3/8-16 x 3/4" lg hex flange bolts and hex flange nuts per side as shown in **Fig 3**.

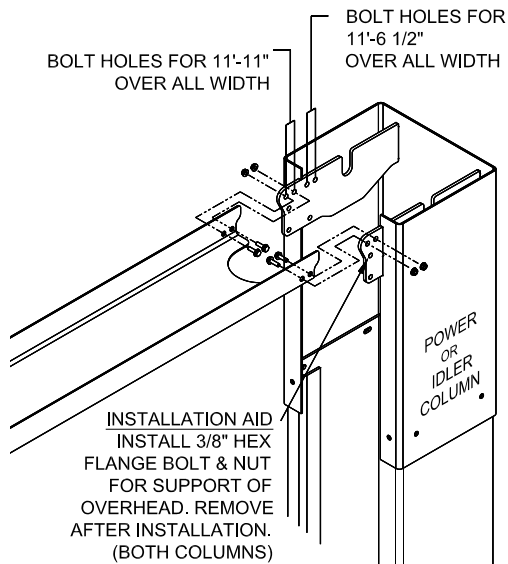

Fig 3 – Overhead Assembly

- 12) Check idler column shimming. Use additional shims (see **Fig. 2**) to remove any gaps that may have been created while installing overhead beam. Tighten anchor bolts and recheck column for plumb. Torque to 150 foot pounds.

- 13) Install Overhead Limit Switch to **REAR** of Power Column using (1) 3/8" pivot pin, (1) 3/8" flat washer and (1) hairpin cotter pin as shown below. Switch **MUST** pivot freely on pin for proper function. **NOTE** switch tube cord is to be oriented **above** pivot pin as shown in **Fig 4a**. Leave switch cord hanging at this time.

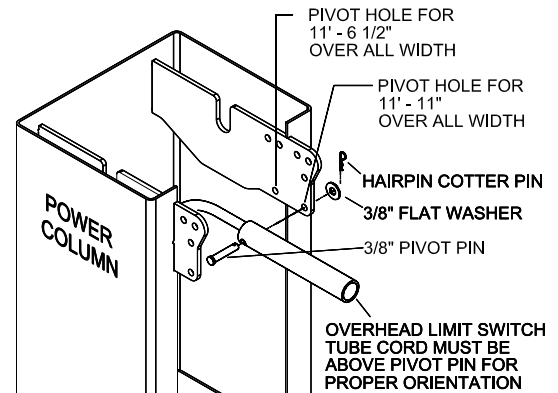

Fig 4a – Overhead Limit Switch Sub-Assembly

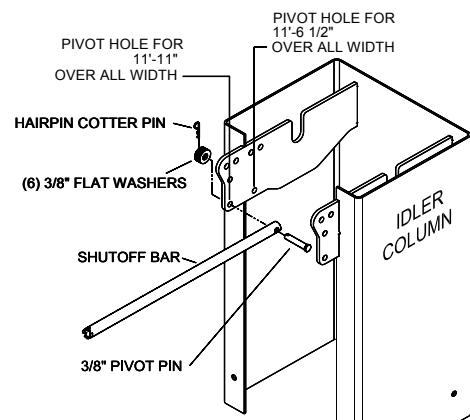

Fig 4b – Overhead Limit Switch Sub-Assembly

IMPORTANT: There are two overall width settings. Insure to place the limit switch and shutoff bar in the proper pivot holes as shown in Fig's 4a & 4b.

- 14) Repeat **procedure 12** for shut-off bar. Insert shut-off bar in switch tube on power column side and take other end to idler side. Attach shut-off bar to idler column in same manner as switch tube.

Insure that both switch tube and shut-off assemblies pivot freely for proper operation.

- 15) Assemble the sheaves and spacers onto the sheave pin as shown in **Fig 5**. Set in cradle with all assembly parts between the two plates.

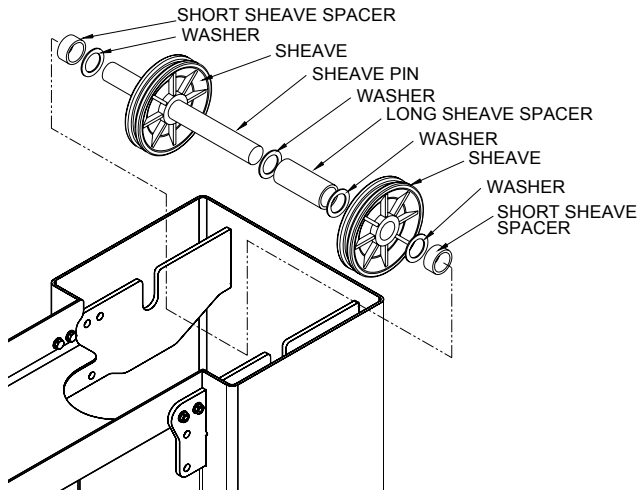

Fig 5 – Sheave Assembly

LOCKING PAWL

- 16) Install Power Column locking pawl and lock release clevis with 5/8" diameter x 1 1/2" lg shoulder bolt and 1/2"-13 nylon lock nut, **Fig. 6**. Attach 3/8" O.D. extension spring to upper hole in locking pawl and other end to hole in bracket welded to column.

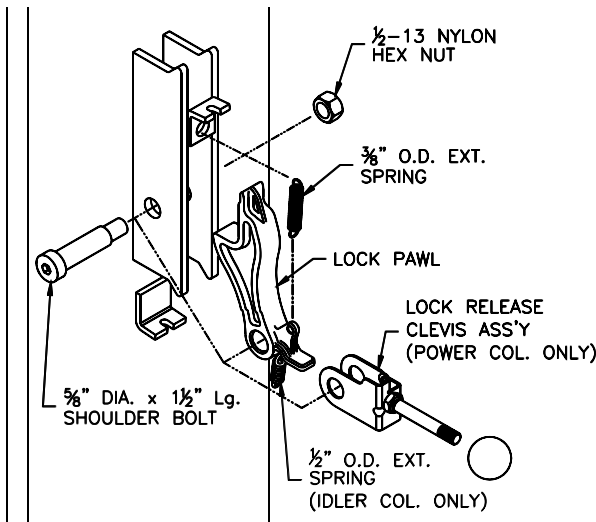

Fig 6 – Locking Pawl Assembly

- 17) Attach 1/2" O.D. extension spring to hole located on bottom side of Idler Column lock pawl and install using 5/8" shoulder bolt and lock nut, **Fig 6**. Attach 3/8" O.D. spring the same as Power side.

SYNCHRONIZER CABLES

- 18) Attach one end of synchronizing cable to carriage. See **Fig 7** for proper attachment.

- 19) Route cable up and over sheave in overhead. Follow across to other sheave on opposite column. Route down through carriage to sheave in bottom of column. Route under sheave and up to cable attachment. Use **Fig 7** for proper attachment.

- 20) Repeat for opposite side.

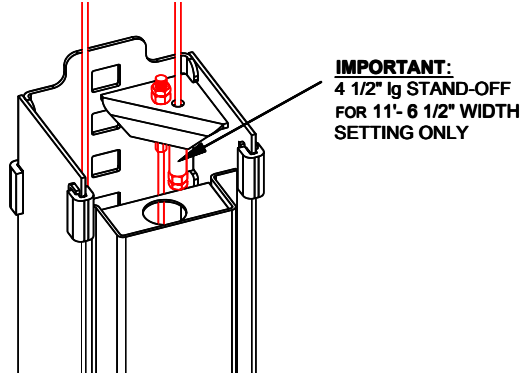

Fig 7 – Cable Assembly

IMPORTANT:

Stand-Offs to be used only on the 11'- 6 1/2" Overall Width Setting.

POWER UNIT & HYDRAULIC LINES

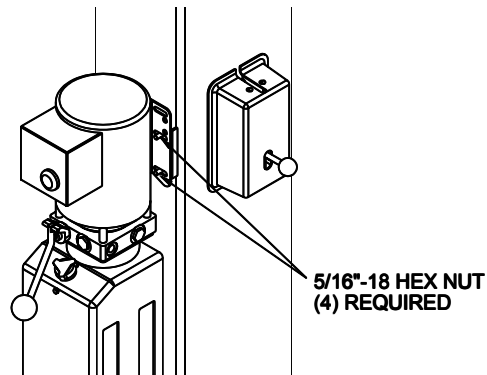

Fig 8 – Power Unit Mounting

- 21) Mount Power Unit to power column as shown in **Fig 8**. The mounting hardware, (4) 5/16"-18 hex nuts, are pre-installed on power unit mounting bracket.

- 22) Uncoil Idler side hose and route through the Idler Side column extension as shown in **Fig 9a**. taking care to avoid the synchronizing cables and hydraulic cylinder path. Remove slack and tighten all 3 clamps. Route hose across overhead avoiding the synchronizing cables and down through the Power Side column extension as seen in **Fig 9b**. Do Not Tighten Clamps at this time.

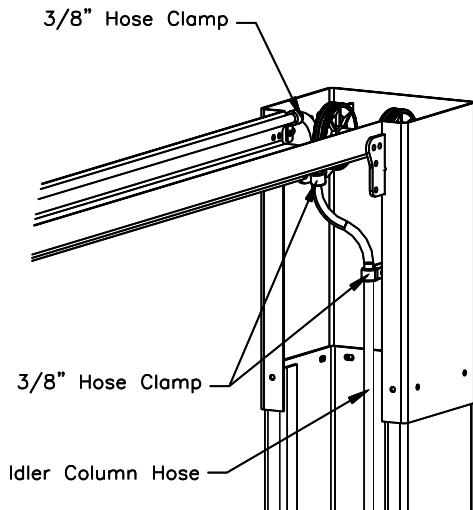

Fig 9a – Idler Side Column Ext. Hose Routing

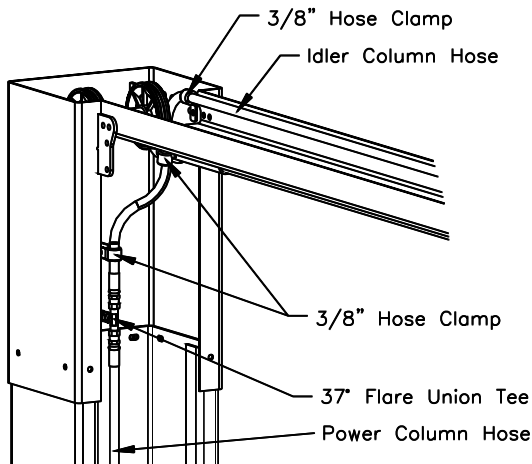

Fig 9b – Power Side Column Ext. Hose Routing

- 23) Loosely attach power column hose and idler column hose using the tee fitting (*in hardware box*) Attach Power Unit Hose to power side column extension as seen in **Fig 10a**. Connect Power unit hose to tee from **Fig 9b** and remove slack from power column hose. Tighten loose fittings and clamps from previous step. Serpentine any extra hose length in overhead.

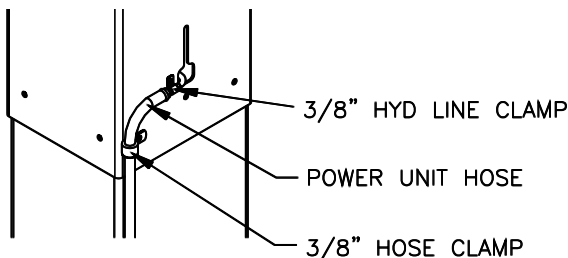

Fig 10a – Power Unit Hose

- 24) Thread 9/16-18 O-ring elbow (*in hardware box*) into power unit. Attach free end of power unit hose to elbow. See **Fig 10b**. CAUTION do not damage rubber O-ring.

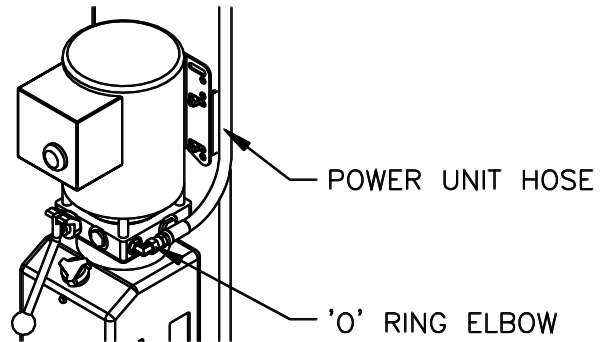

Fig 10b Power Unit Connection

- 25) **BE CERTAIN ALL FITTINGS AND CONNECTIONS ARE TIGHT. IT IS THE INSTALLERS RESPONSIBILITY TO INSURE SYSTEM IS LEAK-FREE.** Fill the Power Unit with three gallons of clean 10wt anti-foam anti-rust hydraulic oil or Dexron III ATF. **Do NOT USE OILS WITH DETERGENTS.**

FOR LIFTS WITH OPTIONAL DUAL PENDANT CONTROL, SKIP STEPS 26 THRU 36 AND REFER INSTEAD TO THE "DUAL PENDANT CONTROL INSTALLATION & OPERATION MANUAL SUPPLEMENT".

LOCK RELEASE

- 26) Attach Mechanical Lock Release Cable Assembly to Power Column Lock Release Clevis using the 3/16" diameter x 1/2" long pin and (2) "C" clip retainers, **Fig 11**.
- 27) Insert threaded sleeve portion of cable assembly in slot located on tab above locking pawl, **Fig 11**. One jam nut should be located on each side of tab. Position threaded sleeve with 1/2" of thread below tab as indicated in **Fig 11** and tighten jam nuts.

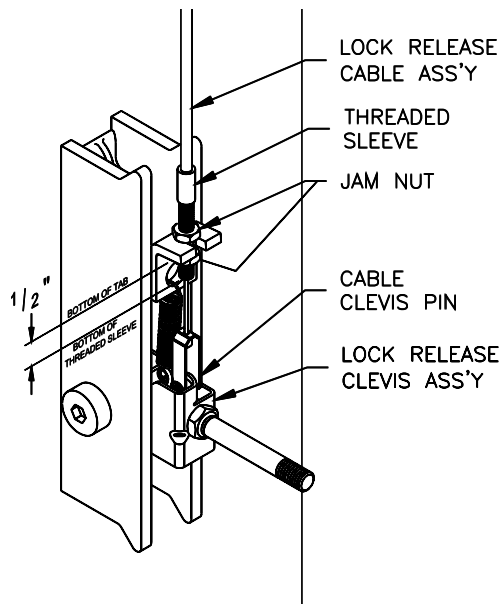

Fig 11 – Power Column Lock Assembly

- 28) Route opposite end of cable assembly up Power Column and into column through access slot in bottom of Column Extension. Following the path of the hydraulic line, route cable assembly across overhead clear of moving parts and back out through access slot in bottom of idler side column extension. Attach Cable Assembly to the hydraulic hose with loosely fit wire ties.

NOTE: DO NOT kink cable assembly when routing. Tighten and trim wire ties after final cable adjustments have been made

- 29) Attach Adhesive-Backed Tab to Idler Column left of the lock assembly (**Fig 12**). Route Lock Release Cable down left side of Idler Column and secure with loosely fit wire tie to Adhesive-Backed Tab. Attach Cable clevis to 1/2" O.D. Extension Spring.

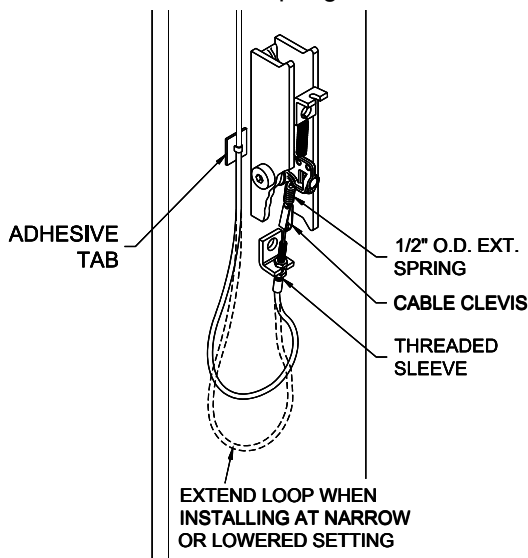

Fig 12 – Idler Column Lock Assembly

- 30) Insert threaded sleeve portion of cable assembly in slot located on tab below lock pawl, **Fig 12**. With one jam nut located on each side of tab, adjust the threaded sleeve to begin to pull tension on the 1/2" O.D. spring. Snug jam nuts by hand.

THE LOCK RELEASE CABLE ADJUSTMENT IS NOT COMPLETE UNTIL THE LIFT HAS BEEN LOWERED AND "FINAL ADJUSTMENTS" HAVE BEEN MADE.

ARM INSTALLATION

- 31) Lubricate the arm pin or carriage arm pin hole with "anti-seize" and install the arms. Insure that the arm restraint gears engage and disengage properly. Arm restraints should disengage when lift is fully lowered. If any binding occurs, insure that the large gear mounted to the arm has been factory installed tight against the arm pin.

ELECTRICAL

- 32) Wire tie Limit Switch cord to column extension hydraulic line and power unit line.
 33) Connect the Overhead Limit Switch Cord to Power Unit as shown in **Fig 13**.
 34) Connect Power Unit to suitable electrical source as shown in **Fig 13**.
 35) **IMPORTANT:** AFTER WIRING HAS BEEN COMPLETED, TEST OPERATION OF POWER UNIT & OVERHEAD LIMIT SWITCH. WHILE RAISING LIFT, OPERATE OVERHEAD SHUTOFF BAR. POWER UNIT MOTOR SHOULD STOP WHEN SHUTOFF BAR IS RAISED.

FINAL ADJUSTMENTS

HYDRAULICS

- 36) Lower the lift to the floor and raise the lift approximately one foot.
 37) Start with Idler side first. Slowly and carefully loosen the bleed plug on top of the cylinder just enough to allow the entrapped air to escape. Repeat for power side.
 38) Raise lift 6 inches. Repeat step 38 until no air comes out of cylinder.
 39) Pressure test hydraulic system. Energize power unit, raise lift to full rise and continue to run motor for additional 10 seconds. (NOTE: pressure relief will make a high pitch squeal sound for these 10 seconds.) Check hydraulic system for leaks.
 40) Energize power unit again for 10 seconds. With a clean rag, wipe down both cylinder rods. (The cylinders are shipped with a small amount of clear anti-corrosive lubricant that will be forced out through the wiper when the lift reaches full rise.) **If lubricant is not wiped clean from the cylinder rod, the cylinder will appear to be leaking.**

Wiring Diagram

*** After wiring has been completed, test operation of Power Unit & Overhead Limit Switch. While raising lift, operate Overhead Shutoff Bar. Power Unit Motor should stop when Shutoff Bar is raised.**

EACH LIFT SHOULD HAVE A DEDICATED CIRCUIT WITH A DOUBLE POLE (THREE POLE FOR 440-480V) BREAKER OR TIME DELAY FUSE SIZED ACCORDING TO THE FOLLOWING CHART

	1Ø 208-240V	3Ø 208V	3Ø 220-240V	3Ø 440-480V
2Hp	25amp	15amp	15amp	5amp

*** WIRING MUST COMPLY WITH NEC AND ALL LOCAL ELECTRICAL CODES ***

FOR SINGLE PHASE

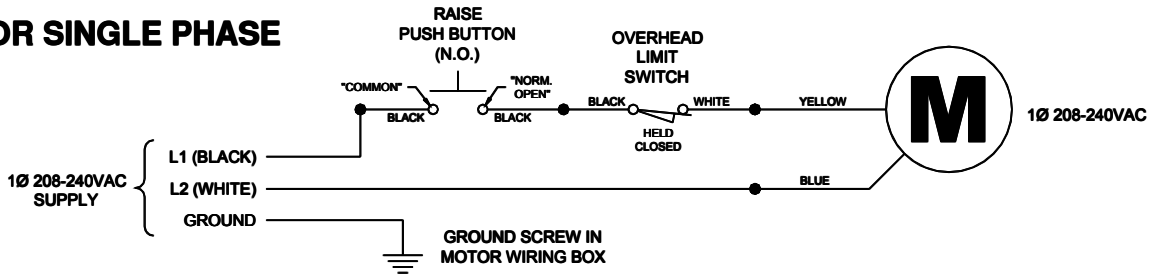

FOR THREE PHASE

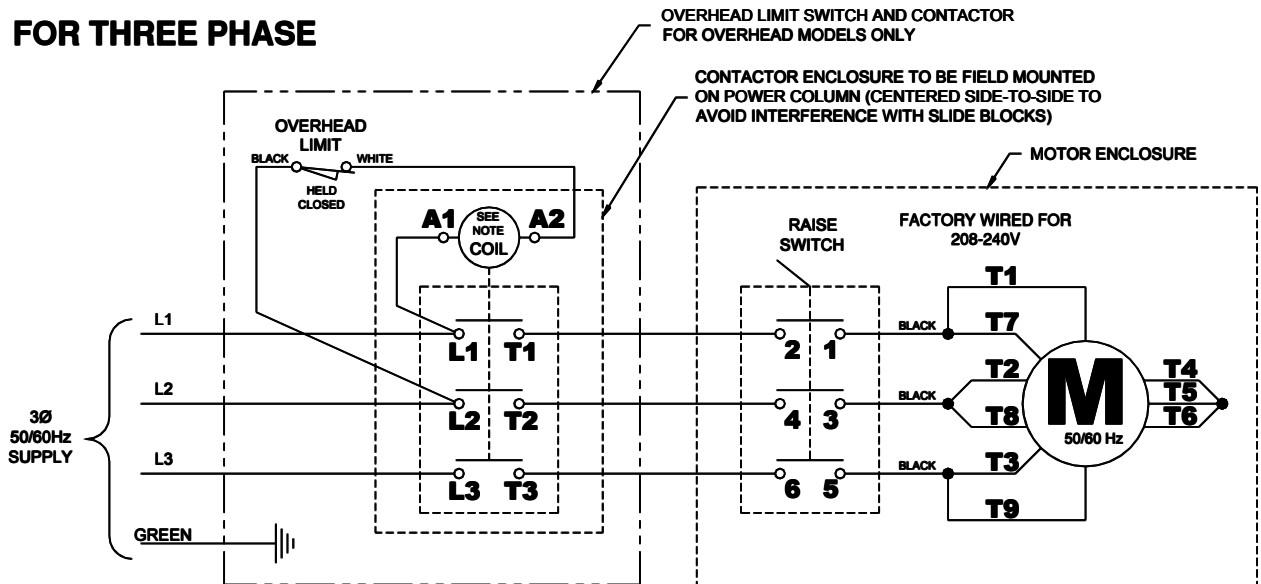

NOTES:

- 1) MOTOR IS FACTORY WIRED FOR 208V OR 220-240V SUPPLY
- 2) MOTOR CONNECTIONS MUST BE RECONFIGURED PER THIS DIAGRAM FOR 440-480V SUPPLY
- 3) CONTACTOR COIL RATING MUST MATCH SUPPLY VOLTAGE (208V, 220-240V, OR 440-480V)
- 4) CONTACTOR MUST BE FIELD MOUNTED ON POWER COLUMN (CENTERED SIDE-TO-SIDE TO AVOID INTERFERENCE WITH SLIDE BLOCKS)
- 5) MOTOR ROTATION IS COUNTER CLOCKWISE FROM TOP OF MOTOR

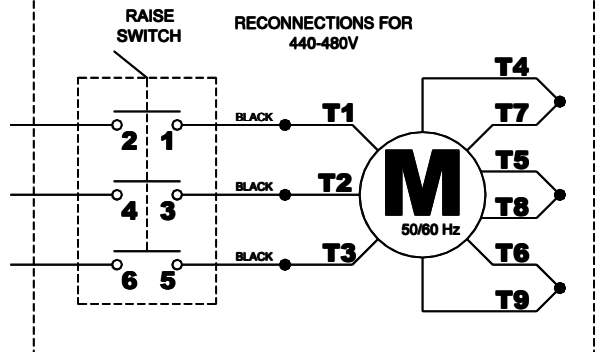

Fig 13 – Electrical Wiring Diagram

FINAL ADJUSTMENTS (CONTINUED)

SYNCHRONIZING CABLES

- 41) Raise lift and insure carriages lower into same lock position.
- 42) Adjust synchronizing cables so the tension is equal in both cables and carriages are firmly sitting on locks.
- 43) Cycle lift to insure that latches operate simultaneously.

LOCK RELEASE CABLE

- 44) Lower lift to the floor and snap plastic cover over Power Column lock assembly.
- 45) Pull and release Power Column lock release handle while watching Idler Column lock. Adjust lower threaded sleeve cable adjuster jam nuts on Idler Column until Idler Column lock disengages and engages fully. When properly adjusted, the idler column lock should just come to rest against the back of the column when engaged and fully out against the tab when disengaged. Tighten Idler Column lower tab jam nuts.

IMPORTANT: IF IDLER SIDE LOCK PAWL DOES NOT FULLY DISENGAGE, DAMAGE MAY RESULT TO IDLER SIDE CARRIAGE AND OR CABLE SYNCHRONIZING SYSTEM.

- 46) Tighten threaded sleeve cable adjuster jam nuts and install lock release knob.
- 47) Tighten and trim wire ties.
- 48) Snap plastic cover over Idler lock assembly (align release cable with notches in cover).

OWNER/OPERATOR CHECKLIST

- 49) Demonstrate the operation of the lift to the owner/operator and review correct and safe lifting procedures using the Lifting It Right booklet as a guide.
- 50) Complete the Installation Checklist/Warranty Validation questionnaire with the owner. Review the terms of the warranty registration card, and return the card and a copy of the questionnaires to:

Challenger Lifts, Inc.

200 Cabell Street
Louisville, KY. 40206

OPERATION PROCEDURE

SAFETY NOTICES AND DECALS

This product is furnished with graphic safety warning labels, which are reproduced on page 3 of these instructions. Do not remove or deface these warning labels, or allow them to be removed or defaced. For your safety, and the safety of others, read and understand all of the safety notices and decals included.

OWNER/EMPLOYER RESPONSIBILITIES

This lift has been designed and constructed according to ANSI/ALI ALCTV-1998 standard. The standard applies to lift manufactures, as well as to owners and employers. The owner/employer's responsibilities as prescribed by ANSI/ALI ALOIM-2000, are summarized below. For exact wording refer to the actual standard provided with this manual in the literature pack.

The Owner/Employer shall insure that lift operators are qualified and that they are trained in the safe use and operation of the lift using the manufacturer's operating instructions; ALI/SM 93 -1, ALI Lifting it Right safety manual; ALI/ST-90 ALI Safety Tips card; ANSI/ALI ALOIM-2000, American National Standard for Automotive Lifts-Safety Requirements for Operation, Inspection and Maintenance; ALI/WL Series, ALI Uniform Warning Label Decals/Placards; and in case of frame engaging lifts, ALI/LP-GUIDE, Vehicle Lifting Points/Quick Reference Guide for Frame Engaging Lifts.

The Owner/Employer shall establish procedures to periodically inspect the lift in accordance with the lift manufacturer's instructions or ANSI/ALI ALOIM-2000, American National Standard for Automotive Lifts-Safety Requirements for Operation, Inspection and Maintenance; and the employer shall insure that the lift inspectors are qualified and that they are adequately trained in the inspection of the lift.

The Owner/Employer shall establish procedures to periodically maintain the lift in accordance with the lift manufacturer's instructions or ANSI/ALOIM-2000, American National Standard for Automotive Lifts-Safety Requirements for Operation, Inspection and Maintenance; and the employer shall insure that the lift maintenance personnel are qualified and that they are adequately trained in the maintenance of the lift.

The Owner/Employer shall maintain the periodic inspection and maintenance records recommended by the manufacturer or ANSI/ALI ALOIM-2000, American National Standard for Automotive Lifts-Safety Requirements for Operation, Inspection and Maintenance.

The Owner/Employer shall display the lift manufacturer's operating instructions; ALI/SM 93 -1, ALI Lifting it Right safety manual; ALI/ST-90 ALI Safety Tips card; ANSI/ALI ALOIM-2000, American National Standard for Automotive Lifts-Safety Requirements for Operation, Inspection and Maintenance; and in the case of frame engaging lift, ALI/LP-GUIDE, Vehicle Lifting Points/Quick Reference Guide for Frame Engaging Lifts; in a conspicuous location in the lift area convenient to the operator.

LIFTING A VEHICLE

- 1) Insure that the lifting arms are parked, out to full drive thru position.
- 2) Position the vehicle in the service bay so that the vehicle's center of gravity is on a line between the two columns, and so the vehicle is centered between the two columns.

DO NOT EXCEED 2250 POUNDS PER ARM.

DO NOT ATTEMPT TO LIFT THE VEHICLE WITH ONLY TWO ARMS, AS THIS WILL VOID THE WARRANTY

INSURE THAT THE HIGHEST POINT ON THE VEHICLE WILL CONTACT THE OVERHEAD LIMIT SWITCH BAR.

DO NOT PLACE THE VEHICLE IN THE SERVICE BAY BACKWARDS.

REFER TO THE VEHICLE MANUFACTURERS SERVICE MANUAL, TECHNICAL BULLETINS, "VEHICLE LIFTING POINTS GUIDE" (ALI/LP-GUIDE) OR OTHER PUBLICATIONS TO LOCATE THE RECOMMENDED LIFTING POINTS.

- 3) Position the arms and adapters so all four pads contact the vehicle simultaneously.

The vehicle should remain level during lifting.

- 4) Raise the lift until all four wheels are off the ground. Test the stability of the vehicle by attempting to rock the vehicle. Check adapters for secure contact with vehicle lift points. If the vehicle seems unstable, lower the lift and readjust the arms. If the vehicle is stable, raise the vehicle to a height a few inches above the desired working height.
- 5) Lower the vehicle until the safety latches on both columns engage. The vehicle should remain level when both latches are engaged. If one side engages and the other continues to descend, stop lowering the vehicle, raise it several inches, and try again to engage both latches.

Always lower lift into locks before entering the area beneath the vehicle.

Always use safety stands when removing or installing heavy components.

LOWERING A VEHICLE

- 1) Insure that the area under the vehicle is clear of personnel and tools.
- 2) Raise the vehicle until both latches are free.
- 3) Disengage the latches by pulling down and holding the lock release lever.
- 4) Lower the vehicle by depressing the lowering valve handle.
- 5) Continue to lower the vehicle until the carriages stop against the base plate. Retract the extension arms, and park them.

MAINTENANCE

To avoid personal injury, permit only qualified personnel to perform maintenance on this equipment.

The following maintenance points are suggested as the basis of a preventive maintenance program. The actual maintenance program should be tailored to the installation. See ANSI/ALI ALOIM booklet for periodic inspection checklist and maintenance log sheet.

- If lift stops short of full rise or chatters, check fluid level and bleed both cylinders per Installation Instructions.
- Replace all Safety, Warning or Caution Labels if missing or damaged (**See *Installation instructions page 3.***)

Daily

- Keep lift components clean.
- Check for loose or broken parts.
- Check hydraulic system for fluid leaks.
- Check adapters for damage or excessive wear. Replace as required with genuine Challenger Lifts parts.
- Check lock release activation. When properly adjusted, the idler column lock should rest firmly against the back of the column when engaged and against the spring mount tab when disengaged.

Weekly

- Check synchronizer cables and sheaves for wear. Replace as required with genuine Challenger Lifts parts.
- Check lock release cable adjustment per Installation Instructions step 42.

IMPORTANT: IF IDLER SIDE LOCK PAWL DOES NOT FULLY DISENGAGE, DAMAGE MAY RESULT TO IDLER SIDE CARRIAGE AND OR CABLE SYNCHRONIZING SYSTEM.

- Check synchronizer cable tension per Installation Instructions. Adjust if necessary.

Monthly

- Torque concrete anchor bolts to 80 ft-lbs.
- Check overhead shutoff switch. While raising lift, operate overhead shutoff bar. Power Unit motor should stop when bar is raised.
- Lubricate carriage slide tracks with heavy viscous grease. (Grease all (4) corners of both columns.)

If any problems are encountered, contact your local service representative.

PARTS BREAKDOWN

Fig A. Column & Overhead

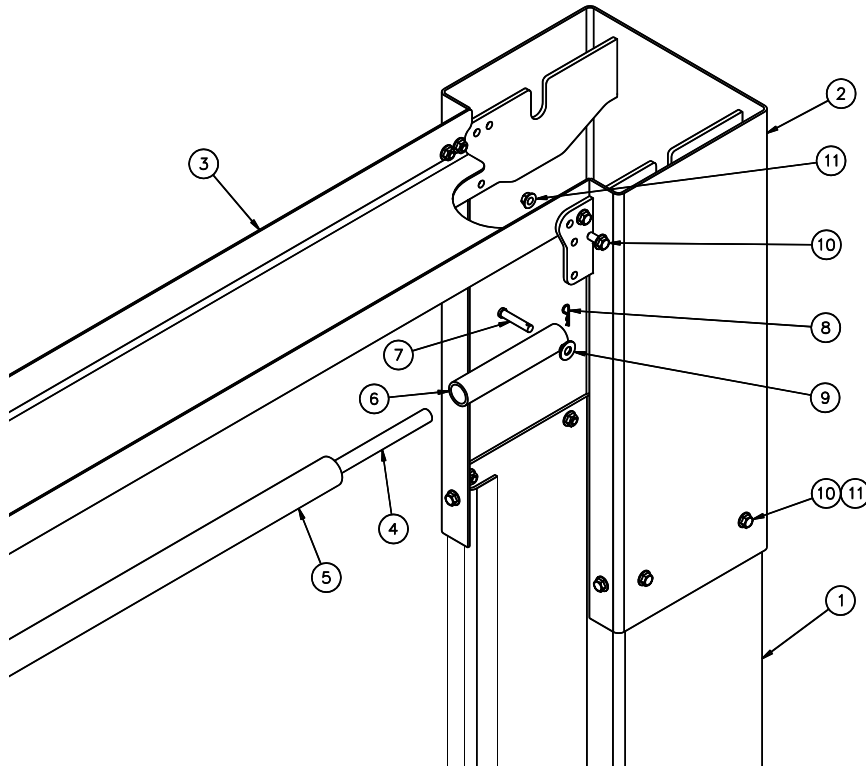

ITEM #	PART #	QTY/LIFT	DESCRIPTION
1	A2010 - P	1	POWER COLUMN WELD
	A2010 - I	1	IDLER COLUMN WELD
2	A2055 - 0	2	COLUMN EXTENSION WELD - CL10
	A2055 - 2		COLUMN EXTENSION WELD - CL10-2
	A2055 - 3		COLUMN EXTENSION WELD - CL10-3
3	A2060	1	OVERHEAD CHANNEL
4	36074	1	SHUTOFF BAR
5	31129	1	PAD
6	36027	1	OVERHEAD LIMIT SWITCH
7	A1064	2	3/8 DIA x 1 7/8 Lg. CLEVIS PIN (SHUTOFF BAR)
8	40124	2	HAIRPIN COTTER PIN
9	31036	7	3/8" FLAT WASHER
10	A1153	24	3/8-16NC HEX.FLG.HD.C.S X 3/4" Lg.
11	A1154	24	3/8-16NC HEX.FLG.NUT

Replace all worn or broken parts with genuine **Challenger Lifts Inc.** parts. Contact your local Challenger Lifts Parts Distributor for pricing and availability. (Call Challenger Lifts Inc. (502) 625-0700 for the Parts Distributor in your area)

PARTS BREAKDOWN (continued)

Fig B. Lock

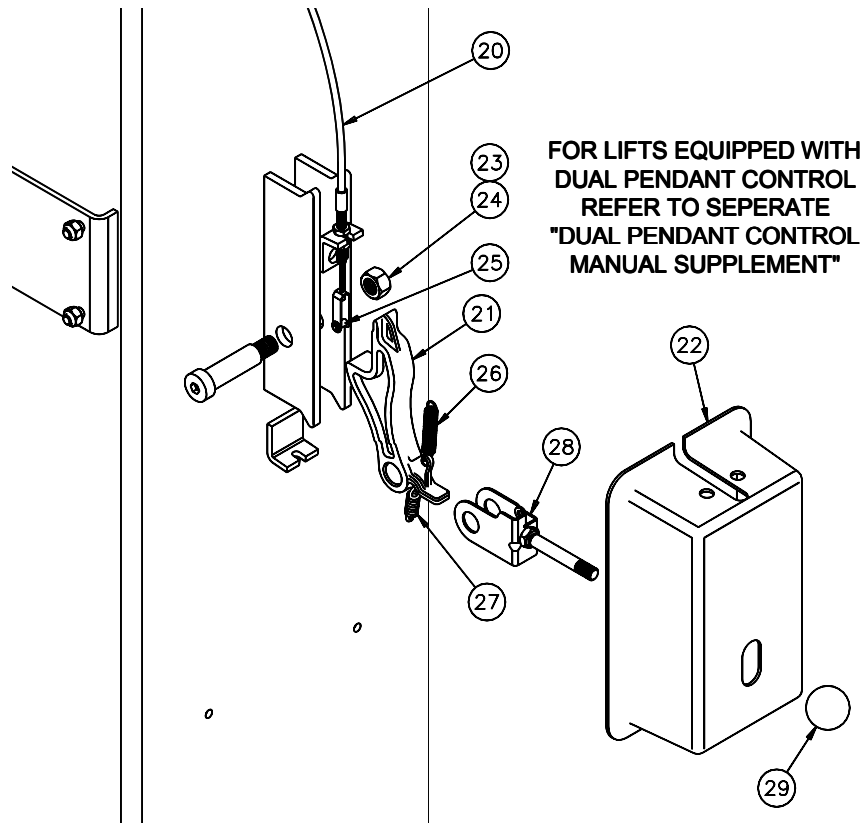

ITEM #	PART #	QTY/LIFT	DESCRIPTION
20	A2135-0	1	LOCK RELEASE CABLE ASSEMBLY - CL10
	A2135-2		LOCK RELEASE CABLE ASSEMBLY - CL10-2
	A2135-3		LOCK RELEASE CABLE ASSEMBLY - CL10-3
21	A1140	2	LOCK PAWL
22	A1133	2	LOCK COVER
23	30020	2	LOCK PIN (5/8 x 1 1/2" Lg. SHOULDER BOLT)
24	37013	2	LOCK PIN RETAINER (1/2-13NC HEX LOCK NUT)
25	37119	1	CLEVIS PIN KIT
26	A1131	2	LOCK SPRING (3/8" O.D.)
27	A1132	1	CABLE SPRING (1/2" O.D.) – Idler side ONLY
28	A1141	1	LOCK RELEASE CLEVIS ASSEMBLY – Power side ONLY
29	36096	1	BALL HANDLE – Power side ONLY

Replace all worn or broken parts with genuine **Challenger Lifts Inc.** parts. Contact your local Challenger Lifts Parts Distributor for pricing and availability. (Call Challenger Lifts Inc. (502) 625-0700 for the Parts Distributor in your area)

PARTS BREAKDOWN (continued)

Fig C. Hydraulics

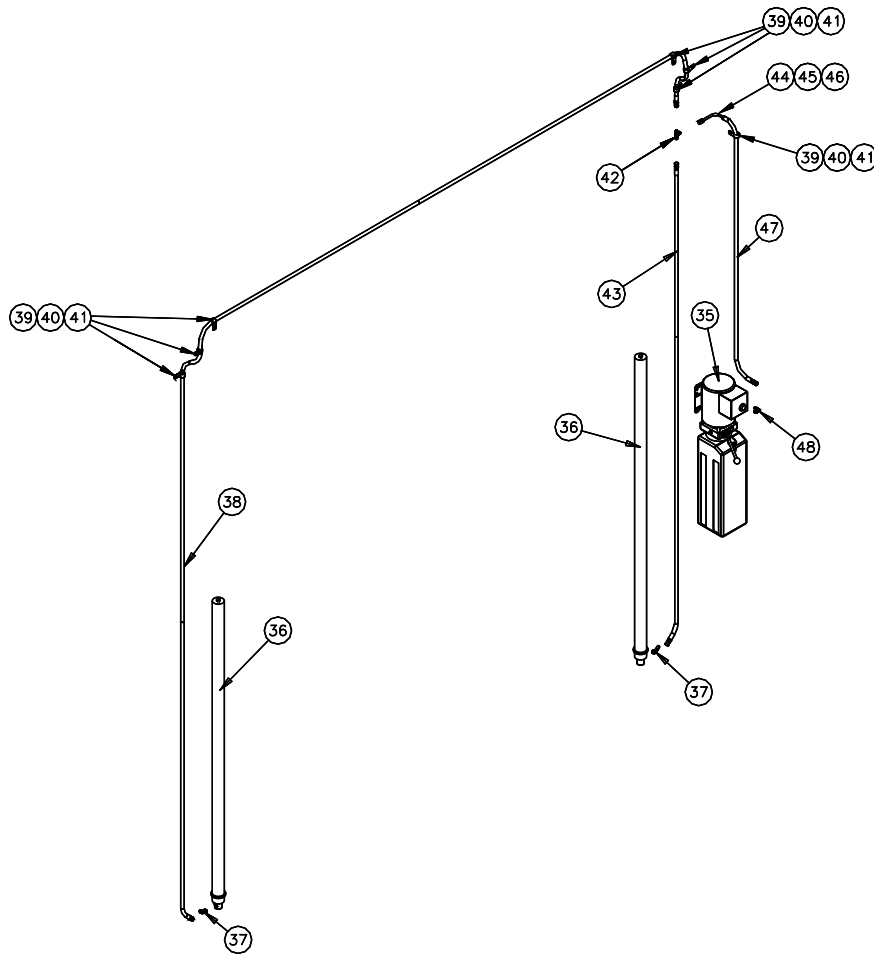

ITEM #	PART #	QTY/LIFT	DESCRIPTION
35	A1201 - 17	1	POWER UNIT 1ph, 60 Hz, 208-230V
	A1203 - 17		POWER UNIT 3ph, 60 Hz, 208-230/460V
36	16138	2	CYLINDER (68" STROKE x 2" BORE)
37	A2128	2	45 Degree ELBOW
38	A2127 - I	1	IDLER HOSE
39	A1122 - 12	7	3/8" HOSE CLAMP
40	A1153	5	3/8-16 x 3/4 HEX FLANGE HEAD BOLT
41	A1154	5	3/8-16 HEX FLANGE NUT
42	39103	1	37 Degree UNION TEE
43	A2127 - P	1	POWER HOSE
44	31025	1	3/8" LINE CLAMP
45	A2125	1	1/4-20 x 3/4 HEX FLANGE HEAD BOLT
46	40085	1	1/4-20 HEX FLANGE NUT
47	A2127 - PU	1	POWER UNIT HOSE
48	16167	1	9/16-18 STRAIGHT THREAD ELBOW

Replace all worn or broken parts with genuine **Challenger Lifts Inc.** parts. Contact your local Challenger Lifts Parts Distributor for pricing and availability. (Call Challenger Lifts Inc. (502) 625-0700 for the Parts Distributor in your area)

PARTS BREAKDOWN (continued)

Fig D. Synchronizer

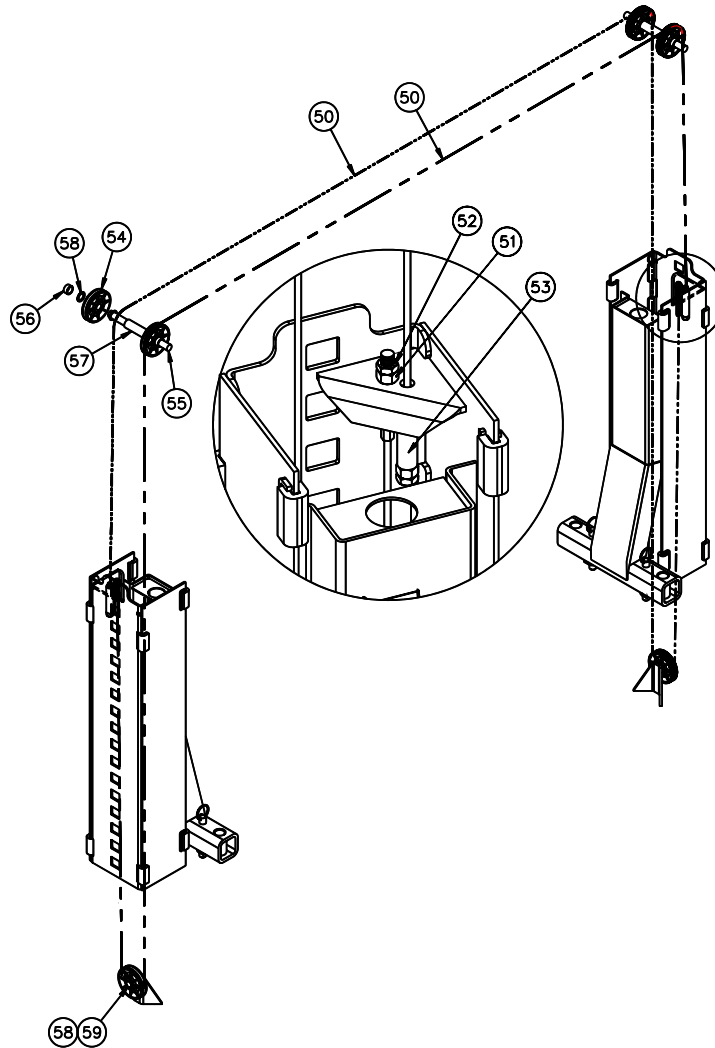

ITEM #	PART #	QTY/LIFT	DESCRIPTION
50	A2115-0	2	SYNCHRONIZER CABLE - CL10
	A2115-2		SYNCHRONIZER CABLE - CL10-2
	A2115-3		SYNCHRONIZER CABLE - CL10-3
51	A2116	4	5/8-11NC HEX NUT
52	A2117	4	5/8-11NC HEX JAM NUT
53	A2118	2	CABLE SPACER (4 1/2" LONG)
54	36025	6	SHEAVE ASSEMBLY (5" DIA. X 5/16" GROOVE)
55	36024	2	SHEAVE PIN
56	A1063-S	4	SHORT SHEAVE SPACER (LINE)
	A2063-S		SHORT SHEAVE SPACER (HOSE)
57	A1063-L10	2	LONG SHEAVE SPACER (LINE)
	A2063-L		LONG SHEAVE SPACER (HOSE)
58	36013	10	1" I.D. SPACER WASHER
59	36014	2	1" EXT. RETAINING RING

Replace all worn or broken parts with genuine **Challenger Lifts Inc.** parts. Contact your local Challenger Lifts Parts Distributor for pricing and availability. (Call Challenger Lifts Inc. (502) 625-0700 for the Parts Distributor in your area)

PARTS BREAKDOWN (continued)

Fig E. Carriage & Arms

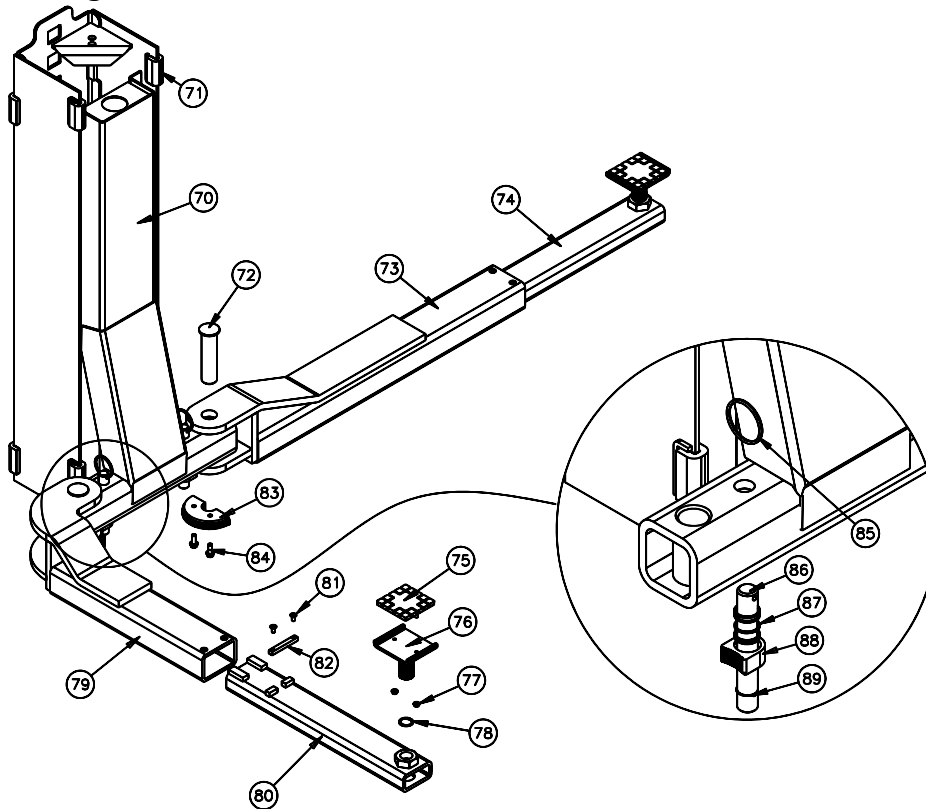

ITEM #	PART #	QTY/LIFT	DESCRIPTION
70	A2025	2	CARRIAGE WELD (LINE)
	B2026		CARRIAGE WELD (HOSE)
71	31023	16	SLIDE BLOCK
72	A1078	4	ARM PIN WELD
73	B2091	2	REAR FEMALE ARM WELD
74	B1094 - R10	2	MALE ARM WELD (REAR)
75	B1104	4	FOOT PAD RUBBER INSERT
76	B1101	4	FOOT PAD WELD
77	B31061	8	M6 KEPS NUT
78	39111	4	FOOT PAD RETAINER RING
79	B2086 - P	1	FRONT FEMALE ARM WELD (POWER)
	B2086 - I	1	FRONT FEMALE ARM WELD (IDLER)
80	B1094 - F	2	MALE ARM WELD (FRONT)
81	B1081	8	M8x1.25 x 16 Flat Socket Head Screw
82	B1082	4	Arm Stop
83	A1070	4	INNER GEAR
84	B1068	8	M10x1.5x25 Hex Flange head Screw
85	A1075	4	PULL RING
86	A1073	4	SHAFT
87	31109	4	COMPRESSION SPRING (RESTRAINT SHAFT)
88	A1072	4	OUTER GEAR
89	36014	4	1" EXT. RETAINING RING
	B2090	2	REAR ARM ASSY (ITEMS NO: 73, 74, 81, 82)
	B2085 - P	1	FRONT ARM ASSY (POWER) (ITEMS NO: 79, 80, 81, 82)
	B2085 - I	1	FRONT ARM ASSY (IDLER) (ITEMS NO: 79, 80, 81, 82)
	B1100	4	FOOT PAD ASSY (ITEMS NO: 75, 76, 77)
	A1077	4	ARM RESTRAINT SHAFT ASSY (ITEMS NO: 85, 86, 87, 88, 89)

Replace all worn or broken parts with genuine **Challenger Lifts Inc.** parts.
Contact your local Challenger Lifts Parts Distributor for pricing and availability.
(Call Challenger Lifts Inc. (502) 625-0700 for the Parts Distributor in your area)

PARTS BREAKDOWN (continued)

Fig E. Carriage & Arms (continued)

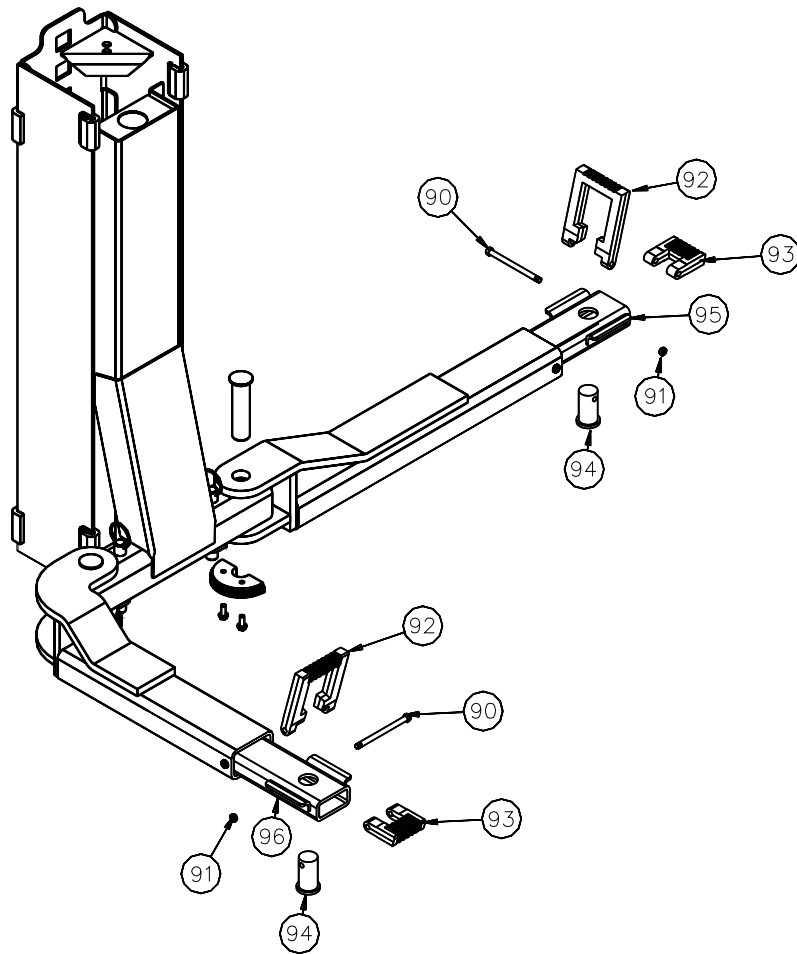

ITEM #	PART #	QTY/LIFT	DESCRIPTION
90	16607M	4	7/16-14 HEX BOLT-MACHINED
91	16608	4	7/16-14 STEEL LOCK JAM NUT
92	16601	4	HIGH PAD
93	16602	4	LOW PAD
94	16603	4	PIN-2 PIECE FLIP UP
95	A1094F - F	2	MALE ARM WELD FRONT
96	A1094F - R10	2	MALE ARM WELD REAR
	A2002F	1	ARM PACK, CL109 2-PIECE FLIP-UP
	A2085F - P	1	FRONT ARM ASSY. 2-PIECE FLIP-UP (POWER)
	A2085F - I	1	FRONT ARM ASSY. 2-PIECE FLIP-UP (IDLER)
	A2090F	2	REAR ARM ASSY. 2-PIECE FLIP-UP

Replace all worn or broken parts with genuine **Challenger Lifts Inc.** parts. Contact your local Challenger Lifts Parts Distributor for pricing and availability. (Call Challenger Lifts Inc. (502) 625-0700 for the Parts Distributor in your area)

BLANK PAGE