

CL Challenger Lifts

Installation, Operation & Maintenance Manual

MODEL RJ7.5

ROLLING JACK

(Model 4015 Series 4-Post only)

7,500 lbs Capacity



PANZITTA SALES & SERVICE
72 George Avenue
Wilkes-Barre, PA 18705
570-822-6720 800-822-6720
www.panzittasales.com

Parts Breakdown

PANZITTA SALES & SERVICE
72 George Avenue
Wilkes-Barre, PA 18705
570-822-6720 800-822-6720
www.panzittasales.com

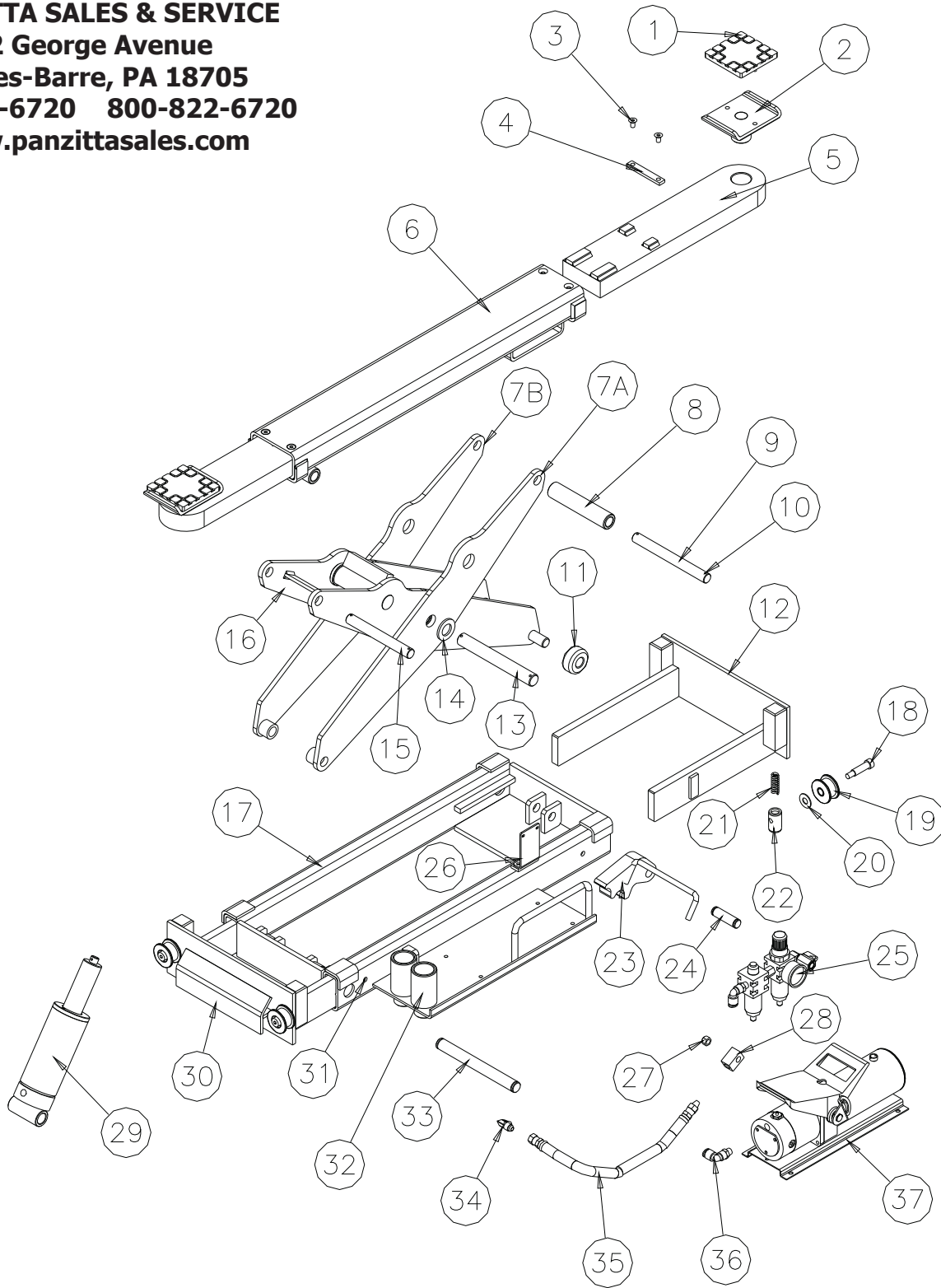

RJ7.5 Installation, Operation and Maintenance Manual

Item Number	Part Number	Qty/Jack	Description
1	A11052	2	Rubber Insert
1A	VS10-35-05	4	M6 Nylon Locknut
2	RJ6-04	2	Foot Pad
3	VS10-31-08	4	M8 x 12 Flat Head Screw
4	RJ6-19	2	Stop Bar
5	RJ6-02CH	2	Arm
6	RJ9-01	1	Sleeve
7A	RJ9-07F	1	Outer Scissor Plate, Front
7B	RJ9-07R	1	Outer Scissor Plate, Rear
8	RJ6-06-04	1	Upper Pin Roller
9	RJ6-13	1	Upper Pin
10	VS10-20-10	6	5mm Roll Pin
10A	X10-099	4	20mm Washer
11	RJ6-18	2	Roller
12	RJ6-15CH	2	Side Member Weld
13	RJ6-08	1	Main Pin
14	RJ6-23	2	Spacer Washer
15	RJ6-12	1	Upper Pin, Fixed End
16	RJ9-06	1	Internal Scissor
17	RJ9-11	1	Jack Body
18	RJ6-27	4	Shoulder Bolt
19	RJ6-17	4	Wheel
20	RJ6-24	4	Nylon Washer
21	RJ6-26	4	Compression Spring
22	RJ6-25	4	Carrier
23	RJ9-16	1	Lock
24	RJ9-20	1	Lock Pin
24A	RJ9-35	2	21mm Snap Ring
25	GZZ	1	FLR Assembly, Including Gage and Fittings
26	RJ6-28	1	FLR Bracket
27	X10-096	1	M10 Nylon Locknut
28	QYB1-4-1	1	Hose Block
28A	RJ6-37	1	4mm x 50mm Cotter Pin
29	RJ6-09CH	1	Cylinder
30	RJ6-15-00CH	2	Side Member Assembly
31	X10-077	4	M10 x 25 HHCS
31A	RJ6-38	4	M10 Hex Nut
32	RJ6-05	2	3" Stack Pad
32A	RJ6-36	2	15mm Snap Ring
33	RJ6-14	1	Cylinder Pin
34	RJ6-22CH	1	Hydraulic Elbow
35	RJ6-21CH	1	Hydraulic Hose
36	RJ6-31	2	10mm Push Loc Elbow
37	QYB1-00	1	Air/Oil Pump

IMPORTANT!

Replace all worn or broken parts with **genuine Challenger Lifts, Inc. parts**. Contact your local Challenger Lifts parts distributor for pricing and availability.