

Multi-Purpose Surface Mounted Lift

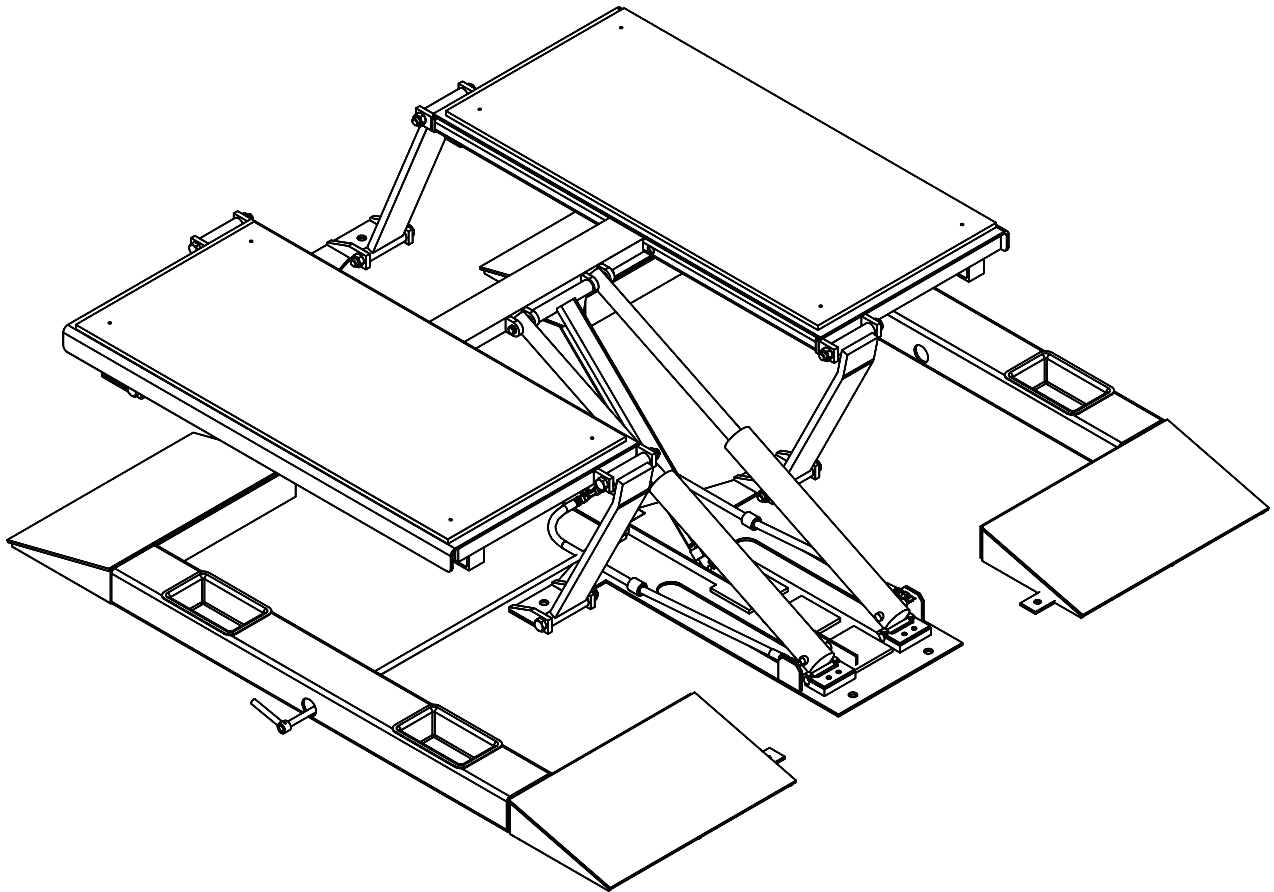

PANZITTA SALES & SERVICE
72 George Avenue
Wilkes-Barre, PA 18705
570-822-6720 800-822-6720
www.panzittasales.com

General Specifications

| | |
|-------------------------|--------------------------------|
| Maximum Capacity | 10000 U.S. Pounds |
| Lowered Height..... | 4 1/4 inches |
| Raised Height | 22 inches |
| Locking Bar Height..... | 13 3/4", 18 3/8", 21 1/4" |
| Overall Width | 85 inches |
| Overall Length | 90 9/16 inches |
| Rearward Movement..... | 13 1/4 inches |
| Motor..... | 1 Hp, 115 Volt, 1 phase, 60 Hz |

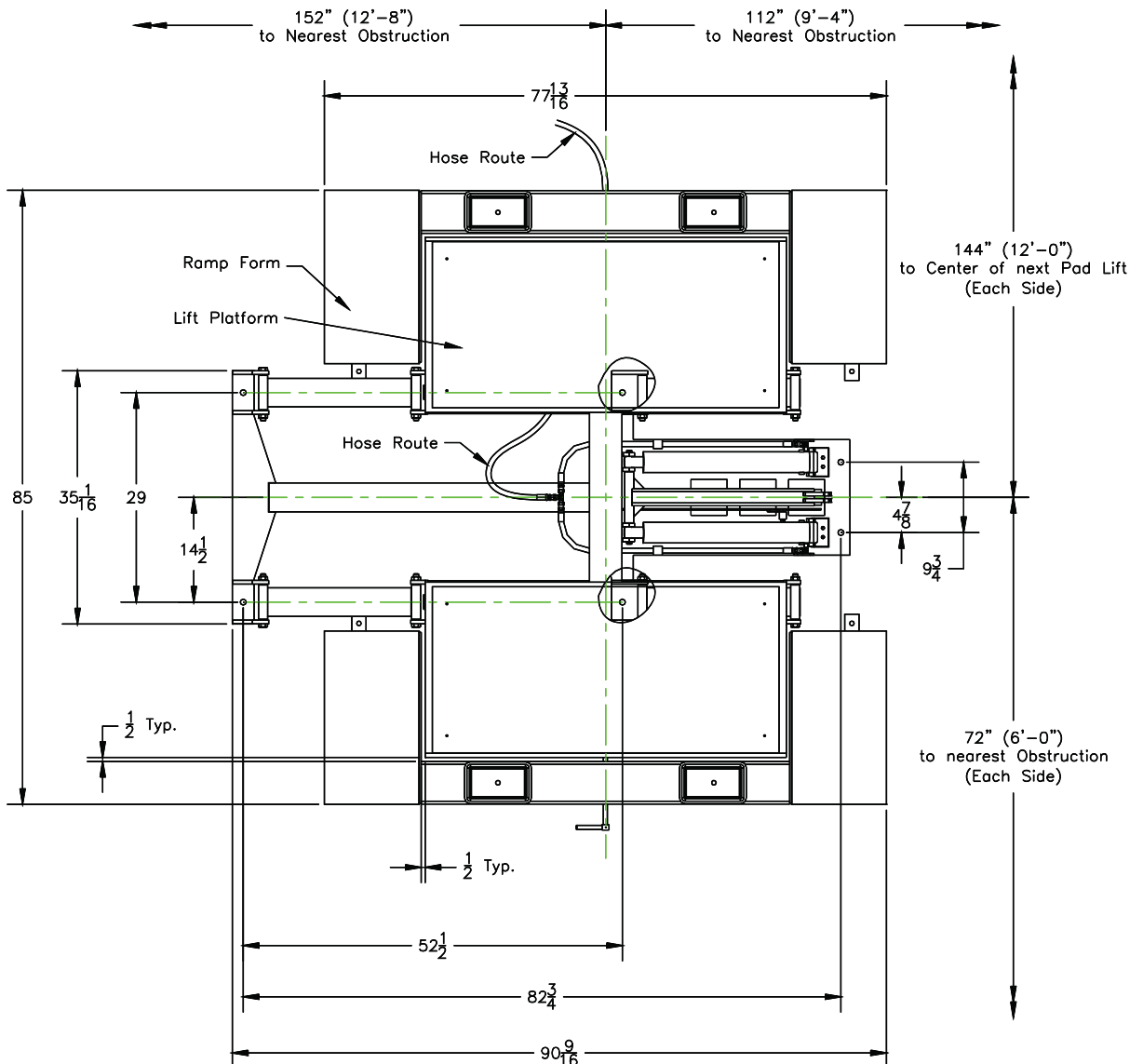
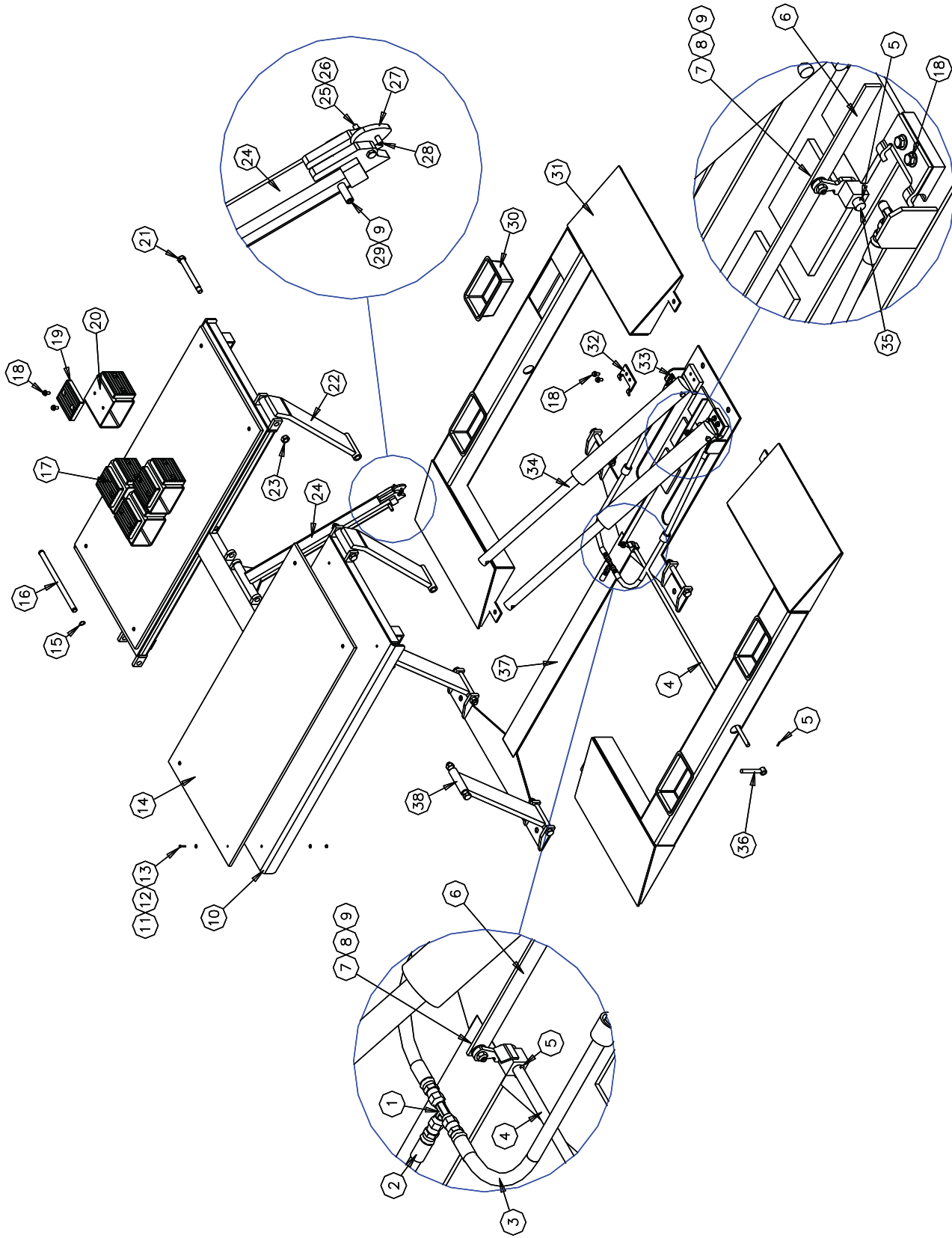

Fig. 1 General Layout

PANZITTA SALES & SERVICE
72 George Avenue
Wilkes-Barre, PA 18705
570-822-6720 800-822-6720
www.panzittasales.com



PANZITTA SALES & SERVICE
72 George Avenue
Wilkes-Barre, PA 18705
570-822-6720 800-822-6720
www.panzittasales.com

Models SR10 and SRM10

| ITEM # | PART # | QTY/LIFT | DESCRIPTION |
|--------|------------|----------------|---|
| 1 | 60-0105 | 1 | #6 JIC Male Branch Tee |
| 2 | 62-0011 | 1 | 20 Foot x 3/8" Hydraulic Hose, #6 JIC Female Ends |
| | 62-0011-30 | 1 | 30 Foot x 3/8" Hydraulic Hose, #6 JIC Female Ends |
| 3 | 62-0012 | 2 | 38 inch x 3/8" Hydraulic Hose, #6 JIC Female Ends |
| 4 | SR-0100 | 1 (SRM10 only) | Lock Release Rod Weld |
| 5 | SR-0122 | 3 (SRM10 only) | 5mm x 19mm Roll Pin |
| 6 | SR-0103 | 1 (SRM10 only) | Lock Release Bar |
| 7 | SR-0123 | 2 (SRM10 only) | 8mm x 12.7mm Shoulder Bolt |
| 8 | SR-0112 | 2 (SRM10 only) | 8mm Flat Washer |
| 9 | SR-0113 | 3 (SRM10 only) | M6 Nylon Locknut |
| 10 | 03-0383 | 1 | Platform Weld |
| 11 | 028-161 | 8 | #10-24 x 1 Pan Head Screw |
| 12 | 108-024 | 16 | #10 Flat Washer |
| 13 | 055-127 | 8 | #10-24 Nylon Locknut |
| 14 | 10-0025 | 2 | Rubber Pad |
| 15 | SR-0121 | 2 | 19mm External Snap Ring |
| 16 | 73-0934 | 1 | Main Pivot Pin |
| 17 | 01-0235 | 4 | Spacer Block Assembly |
| 18 | B1153 | 20 | M10 x 19mm Hex Flange Head Screw |
| 19 | 482365 | 8 | Rubber Lift Pad |
| 20 | 74-0239 | 4 | Spacer Tube |
| 21 | SR-0124 | 8 | Leg Pivot Bolt, 19mm x 155mm with M18 Thread |
| 22 | 03-0382 | 2 | Front Leg Weld |
| 23 | SR-0114 | 8 | M18 Nylon Locknut |
| 24 | 03-0384 | 1 | Lock Leg Weld |
| 25 | 028-077 | 1 (SR10 only) | 1/4-20 x 2 Hex Head Capscrew |
| 26 | 055-160 | 1 (SR10 only) | 1/4-20 Nylon Locknut |
| 27 | 71-0273 | 1 (SR10 only) | Lock Release Cam |
| 28 | 061-081 | 1 (SR10 only) | 1/4 x 1 1/4 Roll Pin |
| 29 | SR-0115 | 1 (SRM10 only) | Lock Release Pin |
| 30 | SR-0125 | 4 | Lug Nut tray |
| 31 | 03-0392 | 2 | Ramp Weldment |
| 32 | 73-0769 | 2 | Cylinder Retainer |
| 33 | SR-0116 | 2 | Union Elbow 1/4 NPT x #6 JIC Male |
| 34 | 63-0022 | 2 | Hydraulic Cylinder, 2 1/4 x 18 |
| 35 | SR-0101 | 1 (SRM10 only) | Linkage Weld |
| 36 | SR-0102 | 1 (SRM10 only) | Lock Release Handle |
| 37 | 03-0385 | 1 | Base Weld |
| 38 | 03-0381 | 2 | Rear Leg Weld |
| | | | |
| | SR10-001 | 1 | Height Adapter Kit (4 pieces item 17) |
| | SR10-002 | 1 | Hose and Fitting Kit (includes items 1, 2, 3, and 33) |
| | SR10-003 | 1 | Hardware Box, Models SR10 and SRM10 |
| | SR10-004 | 1 | Literature Pack, Models SR10 and SRM10 |
| | | | |
| | | | |
| | | | |

PANZITTA SALES & SERVICE
72 George Avenue
Wilkes-Barre, PA 18705
570-822-6720 800-822-6720
www.panzittasales.com

Models SR10 and SRM10

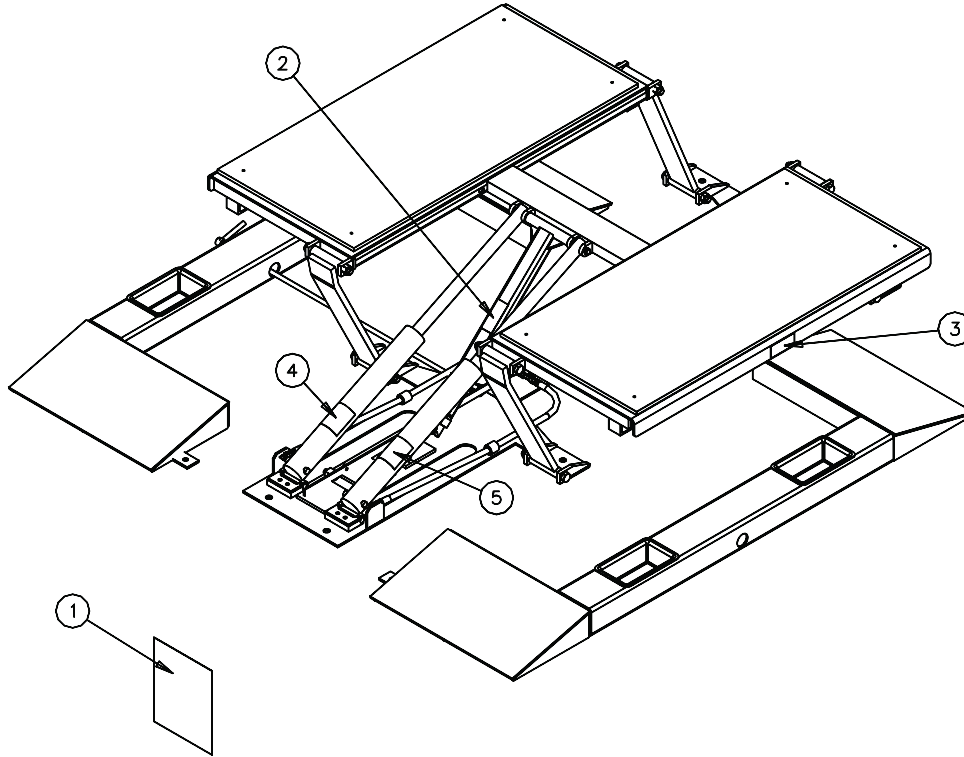

80-0147



80-0148



80-0150



80-0151

| ITEM | QTY | PART NO. | DESCRIPTION |
|------|-----|----------|-------------------------------|
| 1 | 1 | 485412 | ALI Warning Placard, Low Rise |
| 2 | 1 | 80-0147 | Caution Decal |
| 3 | 2 | 80-0148 | Warning Decal |
| 4 | 1 | 80-0150 | Caution Decal |
| 5 | 1 | 80-0151 | Warning Decal |

PANZITTA SALES & SERVICE

72 George Avenue

Wilkes-Barre, PA 18705

570-822-6720 800-822-6720

www.panzittasales.com

Models SR10 and SRM10

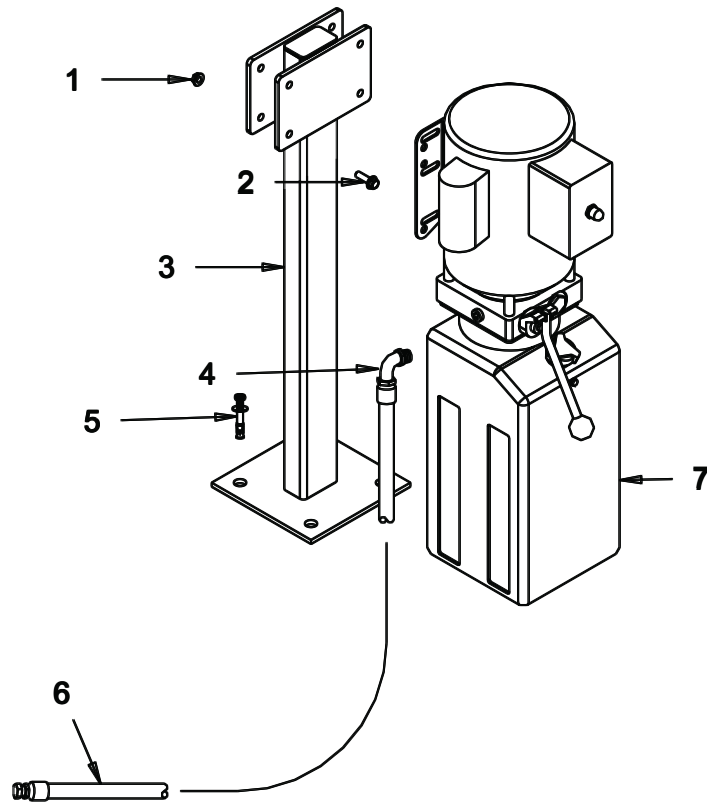

| ITEM | QTY | PART NO. | DESCRIPTION |
|------|-----|-----------------------|--------------------------------------|
| 1 | 4 | 4100237 | 5/16-18 Hex Flange Nut |
| 2 | 4 | A1069 | 5/16-18 x 1 Hex Flange Head Bolt |
| 3 | 1 | 03-0196/03-0389 | Power Unit Stand / 7 Foot Stand |
| 4 | 1 | 16167 | 9/16 O Ring x 37 Deg. Elbow |
| 5 | 4 | 68029 | Anchor Bolt, 1/2 x 3 1/2" lg |
| 6 | 2 | 62-0011 or 62-0011-30 | 3/8" Hydraulic Hose x 20'lg or 30'lg |
| 7 | 1 | 67010 | AC., Power Unit 60Hz |

PANZITTA SALES & SERVICE
72 George Avenue
Wilkes-Barre, PA 18705
570-822-6720 800-822-6720
www.panzittasales.com