

**TWO STAGE/FOUR CYLINDER AIR COMPRESSORS & UNITS  
FEATURING THE R30D PUMP**

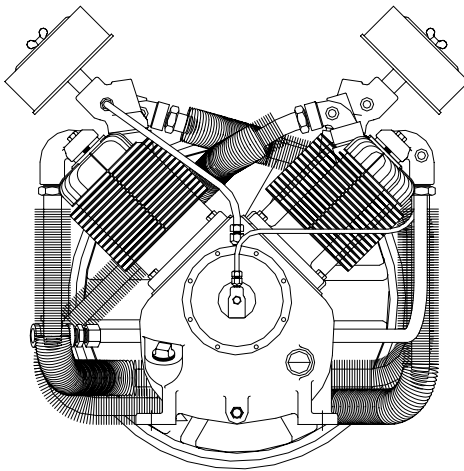

**THIS MANUAL CONTAINS IMPORTANT SAFETY INFORMATION AND SHOULD ALWAYS BE AVAILABLE TO THOSE PERSONNEL OPERATING THIS UNIT. READ, UNDERSTAND AND RETAIN ALL INSTRUCTIONS BEFORE OPERATING THIS EQUIPMENT TO PREVENT INJURY OR EQUIPMENT DAMAGE.**



**C408-A  
(Ref. Drawing)**

**MODEL R30D COMPRESSOR**

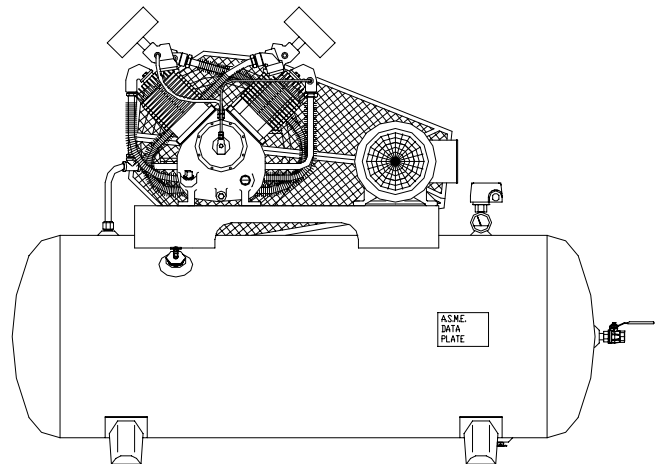

**C476-A  
(Ref. Drawing)**

**MODEL HR10-12 UNIT**

## **MAINTAIN COMPRESSOR RELIABILITY AND PERFORMANCE WITH GENUINE GARDNER DENVER COMPRESSOR PARTS AND SUPPORT SERVICES**

Gardner Denver Compressor genuine parts, manufactured to design tolerances, are developed for optimum dependability – specifically for Gardner Denver compressor systems. Design and material innovations are the result of years of experience with hundreds of different compressor applications. Reliability in materials and quality assurance are incorporated in our genuine replacement parts.

Your authorized Gardner Denver Compressor distributor offers all the backup you'll need. A worldwide network of authorized distributors provides the finest product support in the air compressor industry. Your authorized distributor can support your Gardner Denver air compressor with these services:

1. Trained parts specialists to assist you in selecting the correct replacement parts.
2. A full line of factory tested AEON™ compressor lubricants specifically formulated for use in Gardner Denver compressors.
3. Repair and maintenance kits designed with the necessary parts to simplify servicing your compressor.

Authorized distributor service technicians are factory trained and skilled in compressor maintenance and repair. They are ready to respond and assist you by providing fast, expert maintenance and repair services.

**For the location of your local authorized Gardner Denver Air Compressor distributor, refer to the yellow pages of your phone directory or contact:**

**Factory:**

Gardner Denver  
1301 North Euclid Avenue  
Princeton, IL 61356

Phone: (815) 875-3321

Fax: (815) 872-0421

E-Mail: [Champion@Championpneumatic.com](mailto:Champion@Championpneumatic.com)

### **INSTRUCTIONS FOR ORDERING REPAIR PARTS**

When ordering parts, specify Compressor MODEL, HORSEPOWER and SERIAL NUMBER (see nameplate on unit). All orders for Parts should be placed with the nearest authorized distributor.

Order by part number and description. Reference numbers are for your convenience only.

# TABLE OF CONTENTS

---

<b>Subject</b>	<b>Page</b>
Safety And Operation Precautions.....	4
Explanation Of Safety Instructions Symbols And Decals.....	5
Introduction .....	6
Warranty.....	6
Dimensions And Specifications.....	7
Installation.....	8, 9, & 10
Operation .....	11 & 12
Maintenance.....	12,13,14 & 15
Compressor Oil Specifications.....	16
Lubricant .....	16
Torque Valves.....	16
Trouble Shooting Guide .....	17 & 18
Parts List.....	19 thru 26
Constant Speed Head Unloader Kit.....	27
Unit Hazard Decal & Tags .....	28 & 29
Pump Hazard Decals & Tags.....	30
Record Of Maintenance Service .....	31

## SAFETY AND OPERATION PRECAUTIONS

---

Because an air compressor is a piece of machinery with moving and rotating parts, the same precautions should be observed as with any piece of machinery of this type where carelessness in operation or maintenance is hazardous to personnel. In addition to the many obvious safety rules that should be followed with this type of machinery, the additional safety precautions as listed below must be observed:

1. Read all instructions completely before operating air compressor or unit.
2. For installation, follow all local electrical and safety codes, as well as the National Electrical Code (NEC) and the Occupational Safety and Health Act (OSHA).
3. Electric motors must be securely and adequately grounded. This can be accomplished by wiring with a grounded, metal-clad raceway system to the starter; by using a separate ground wire connected to the bare metal of the motor frame; or other suitable means.
4. Protect the power cable from coming in contact with sharp objects. Do not kink power cable and never allow the cable to come in contact with oil, grease, hot surfaces, or chemicals.
5. Make certain that the power source conforms to the requirements of your equipment.
6. Pull main electrical disconnect switch and disconnect any separate control lines, if used, before attempting to work or perform maintenance on the air compressor or unit. "Lock out" or "Tag out" all power sources.
7. Do not attempt to remove any compressor parts without first relieving the entire system of pressure.
8. Do not attempt to service any part while machine is in an operational mode.
9. Do not operate the compressor at pressures in excess of its rating.
10. Do not operate compressor at speeds in excess of its rating.
11. Periodically check all safety devices for proper operation. Do not change pressure setting or restrict operation in any way.
12. Be sure no tools, or rags or loose parts are left on the compressor or drive parts.
13. Do not use flammable solvents for cleaning the air inlet filter or element and other parts.
14. Exercise cleanliness during maintenance and when making repairs. Keep dirt away from parts by covering parts and exposed openings with clean cloth or Kraft paper.
15. Do not operate the compressor without guards, shields and screens in place.
16. Do not install a shut-off valve in the discharge line, unless a pressure relief valve, of proper design and size, is installed in the line between the compressor unit and shut-off valve.
17. Do not operate compressor in areas where there is a possibility of ingesting flammable or toxic fumes.
18. Be careful when touching the exterior of a recently run motor - it may be hot enough to be painful or cause injury. With modern motors this condition is normal if operated at rated load - modern motors are built to operate at higher temperatures.
19. Inspect unit daily to observe and correct any unsafe operating conditions found.
20. Do not "play around" with compressed air, nor direct air stream at body, because this can cause injuries.
21. Compressed air from this machine absolutely must not be used for food processing or breathing air without adequate downstream filters, purifiers and controls.
22. Always use an air pressure regulating device at the point of use, and do not use air pressure greater than marked maximum pressure of attachment.
23. Check hoses for weak or worn condition before each use and make certain that all connections are secure.
24. Always wear safety glasses when using compressed air gun.

The user of any air compressor package manufactured by **Gardner Denver**, is hereby warned that failure to follow the preceding Safety and Operation Precautions can result in injuries or equipment damage. However, **Gardner Denver** – A Gardner Denver Co., does not state as fact or does not mean to imply that the preceding list of Safety and Operating Precautions is all inclusive, and further that the observance of this list will prevent all injuries or equipment damage.

## **EXPLANATION OF SAFETY INSTRUCTIONS SYMBOLS AND DECALS**



### **DANGER**

Indicates immediate hazards which will result in severe injury or death.



### **WARNING**

Indicates hazards or unsafe practice which could result in severe injury or death.



### **CAUTION**

Indicates hazards or unsafe practice which could result in damage to the Gardner Denver compressor or minor injury.

### **NOTICE**

Notice is used to notify people of installation, operation or maintenance information which is important but not hazard-related.

## **SAFETY AND OPERATION PRECAUTIONS**

**OBSERVE, UNDERSTAND AND RETAIN THE INFORMATION GIVEN IN THE SAFETY PRECAUTION DECALS AS SHOWN IN THE PARTS LIST SECTION**



### **DANGER**

This reciprocating compressor must not be used for breathing air. To do so will cause serious injury whether air is supplied direct from the compressor source or to breathing tanks for later use. Any and all liabilities for damage or loss due to injury, death and/or property damage including consequential damages stemming from the use of this compressor to supply breathing air, will be disclaimed by the manufacturer.



### **WARNING**

The use of this compressor as a booster pump and/or to compress a medium other than atmospheric air is strictly non-approved and can result in equipment damage and/or injury. Non-approved uses will also void the warranty.



### **CAUTION**

This unit may be equipped with special options which may not be included in this manual. User must read, understand and retain all information sent with special options.

# INTRODUCTION

---

Gardner Denver R Series compressors are the result of advanced engineering and skilled manufacturing. To be assured of receiving maximum service from this machine the owner must exercise care in its operation and maintenance. This book is written to give the operator and maintenance department essential information for day-to-day operation, maintenance and adjustment. Careful adherence to these instructions will result in economical operation and minimum downtime.

## WARRANTY

### Gardner Denver Five Year Warranty "R" Series Compressors

**Gardner Denver, Inc. ("the Company")** warrants each new compressor pump manufactured by the Company, mounted on a factory assembled unit, to be free from defects in material and workmanship under normal use and service for a period of sixty (60) months from date of installation or sixty-six (66) months from date of shipment by the Company or the Company distributor, whichever may occur first. **Applies to the compressor pump only, excluding head valves. Valves, controls and accessories are warranted for the first year only.** Compressor pumps purchased separately would carry a one year warranty.

This five year extended warranty will be prorated over the 5 years as follows:

First Year	-	100% Allowance, Parts and Labor
Second Year	-	90% Allowance, Parts and Labor
Third Year	-	80% Allowance, Parts and Labor
Fourth Year	-	70% Allowance, Parts and Labor
Fifth Year	-	60% Allowance, Parts and Labor

**Applies to the Company logo, tank or base mounted complete compressors only.**

### Express Limited Warranty

The Company warrants each new air compressor unit manufactured by the Company to be free from defects in material and workmanship under normal use and service for a period of twelve (12) months from date of installation or eighteen (18) months from date of shipment by the Company or the Company distributor, whichever may occur first.

The Company makes no warranty in respect to components and accessories furnished to the Company by third parties, such as **ELECTRIC MOTORS, GASOLINE ENGINES** and **CONTROLS**, which are warranted only to the extent of the original manufacturer's warranty to the Company. To have warranty consideration, electric motors must be equipped with thermal overload protection.

The extended five year warranty will apply to ASME air receivers provided they are installed on rubber vibro isolator pads or approved equivalent.

**When a compressor pump, or component is changed or replaced during the warranty period, the new/replaced item is warranted for only the remainder of the original warranty period.**

Repair, replacement or refund in the manner and within the time provided shall constitute the Company's sole liability and your exclusive remedy resulting from any nonconformity or defect. THE COMPANY SHALL NOT IN ANY EVENT BE LIABLE FOR ANY DAMAGES, WHETHER BASED ON CONTRACT, WARRANTY, NEGLIGENCE, STRICT LIABILITY OR OTHERWISE, INCLUDING WITHOUT LIMITATION ANY CONSEQUENTIAL, INCIDENTAL OR SPECIAL DAMAGES, ARISING WITH RESPECT TO THE EQUIPMENT OR ITS FAILURE TO OPERATE, EVEN IF THE COMPANY HAS BEEN ADVISED OF THE POSSIBILITY THEREOF.

THE COMPANY MAKES NO OTHER WARRANTY OR REPRESENTATION OF ANY KIND, EXCEPT THAT OF TITLE, AND ALL OTHER WARRANTIES, EXPRESS OR IMPLIED, INCLUDING WARRANTIES OR MERCHANTABILITY AND FITNESS FOR A PARTICULAR PURPOSE, ARE HEREBY EXPRESSLY DISCLAIMED. NO SALESMAN OR OTHER REPRESENTATIVE OF THE COMPANY HAS AUTHORITY TO MAKE ANY WARRANTIES.

## TWO STAGE AIR COMPRESSORS - MODEL R30D

### DIMENSIONS

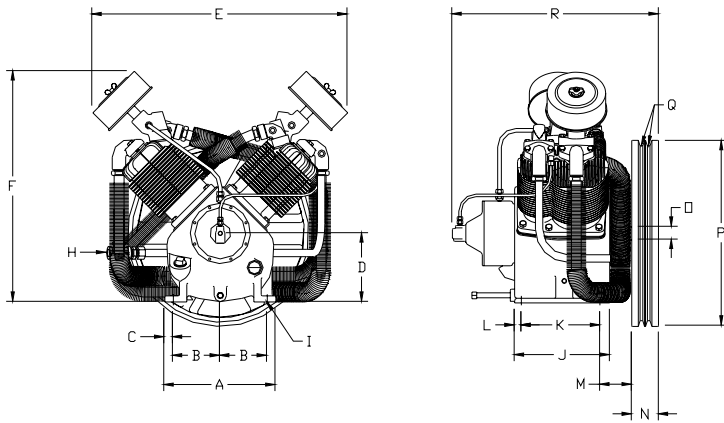

**C407-A**  
(Ref. Drawing)

	ITEM	R30D
A	Base-Width	11-1/8"
B	Bolt Down-Width	4-13/16"
C	Bolt Down to Edge	3/4"
D	Base to Crank Ctr	7"
E	Overall Width	24"
F	Overall Height	23-9/16"
H	HP Exhaust Opening	3/4 NPT
I	Bolt Down Hole Dia.	17/32"
J	Base-Depth	9-3/4"
K	Bolt Down Depth	8-1/16"
L	Bolt Down to Edge	27/32"
M	Bolt Hole to Wheel (Max.)	3-1/16"
N	Flywheel Width	2-23/32"
O	Crank Diameter	1-3/4"
P	Flywheel Diameter	18-7/8"
Q	Flywheel Grooves	2VB
R	Overall Depth	21-1/8"

**Flywheel Rotation** – Clockwise when viewed from front, flywheel to rear.

### SPECIFICATIONS

MODEL	BORE & STROKE (INCHES)	NO. OF CYLINDERS	OIL CAPACITY (QTS.)	WEIGHT (LBS)	PRESSURE (PSIG)	CU FT./REV.	MIN./MAX. RPM
R30D	4-5/8 & 2-1/2 x 3	4	4	220	175	.0583	400/1050

### PERFORMANCE

PUMP	OUTPUT PRESS. PSIG	MOTOR H.P.	PUMP RPM	DISPL. CFM	COOLING AIR FLOW CFM	HEAT REJECTI ON BTU/HR	APPROX. PULLEY O.D. INCHES
R30D	125	7-1/2	670	39.6	975	16,800	7.00
R30D	175	7-1/2	575	33.5	835	16,800	6.20
R30D	125	10	810	48.5	1180	22,400	8.38
R30D	175	10	740	43.1	1075	22,400	8.15
R30D	125	15	1035	60.6	1505	33,600	11.35
R30D	175	15	1035	60.6	1505	33,600	11.35

All data is based on 1750 RPM electric motors as a power source.

$$\text{Pulley Dia. (approx.)} = \frac{\text{Compressor RPM} \times \text{Flywheel Dia.}}{\text{Motor or Engine RPM}}$$

## **INSTALLATION**

 <b>WARNING</b>
--

<b>Do not operate unit if damaged during shipping, handling or use. Operating unit if damaged may result in injury.</b>
---

1. Permanently installed compressors must be located in a clean, well ventilated dry room so compressor receives adequate supply of fresh, clean, cool and dry air. It is recommended that a compressor, used for painting, be located in a separate room from that area wherein body sanding and painting is done. Abrasive particles or paint, found to have clogged the air intake filters and intake valves, shall automatically void warranty.
2. Compressors should never be located so close to a wall or other obstruction that flow of air through the fan bladed flywheel, which cools the compressor, is impeded. Permanently mounted units should have flywheel at least 12" from wall.
3. Place stationary compressors on firm level ground or flooring. Permanent installations require bolting to floor. Bolt holes in tank or base feet are provided. Before bolting or lagging down, shim compressor level. Avoid putting a stress on a tank foot by pulling it down to floor. This will only result in abnormal vibration, and possible cracking of Air Receiver. It is recommended that optional vibro-isolator pads be installed on unit. Tanks bolted directly to a concrete floor without padding will not be warranted against cracking. Gardner Denver vibro-isolators must be used for extended warranty to apply to ASME air receivers.
4. If installing a bare pump or a base mounted unit, make certain the system has adequate pressure limiting controls. Controls could be a pressure switch for start/stop operation or a pilot valve for continuous operation. If a pilot valve is used, the compressor must be equipped with head unloaders. Control air must be piped from the air receiver to the pilot valve.
5. A properly sized air check valve must be installed in the discharge piping, between the compressor outlet and the inlet of any receiver tank(s) in the system.

 <b>DANGER</b>
---

<b>Do not install isolating valves between compressor outlet and air receiver. This will cause excessive pressure if valve is closed, and cause injury and equipment damage.</b>
--

 <b>WARNING</b>
--

<b>Always use an air pressure regulating device at the point of use. Failure to do so can result in injury or equipment damage.</b>
---

 <b>CAUTION</b>
--

- |   |
|---|
| <ul style="list-style-type: none"><li>● <b>Do not install in an area where ambient temperature is below 32 degrees F or above 100 degrees F.</b></li><li>● <b>Do not install unit in an area where air is dirty and/or chemical laden.</b></li><li>● <b>Unit is not to be installed outdoors.</b></li></ul> |
|---|



## INSTALLATION (CONT'D)

### ELECTRICAL POWER SUPPLY

It is essential that the power supply and the supply wiring are adequately sized and that the voltage corresponds to the unit specifications. Branch circuit protection must be provided at installation as specified in the National Electrical Code.

All wiring should be performed by a licensed electrician or electrical contractor. Wiring must meet applicable codes for area of installation. The table gives recommended wire sizes based on the 1999 NEC.

#### WIRE SIZE (AWG) - 75°C COPPER - 30°C AMBIENT

MOTOR HP	3 PHASE			
	200/208V	230V	460V	575V
7-1/2	8 (6)	10 (6)	14 (10)	14 (10)
10	8 (4)	8 (4)	12 (8)	14 (10)
15	6 (2)	6 (3)	10 (6)	10 (8)

Values in ( ) for Duplex Unit w/one incoming power line to both motors.

All models require a properly sized magnetic starter as specified in the National Electric Code (NEC). See Figure 1-1 for simplex wiring diagram and Figure 1-2 for duplex wiring diagram.

If ordered with a factory mounted magnetic starter, compressor is wired at factory. It is necessary only to bring lines from a properly sized disconnect switch to the magnetic starter mounted on the unit.

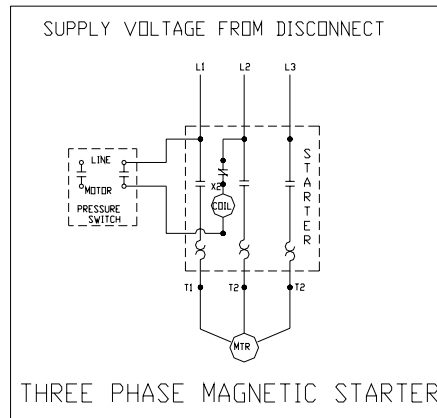

**Figure 1 - Simplex Wiring Diagram**

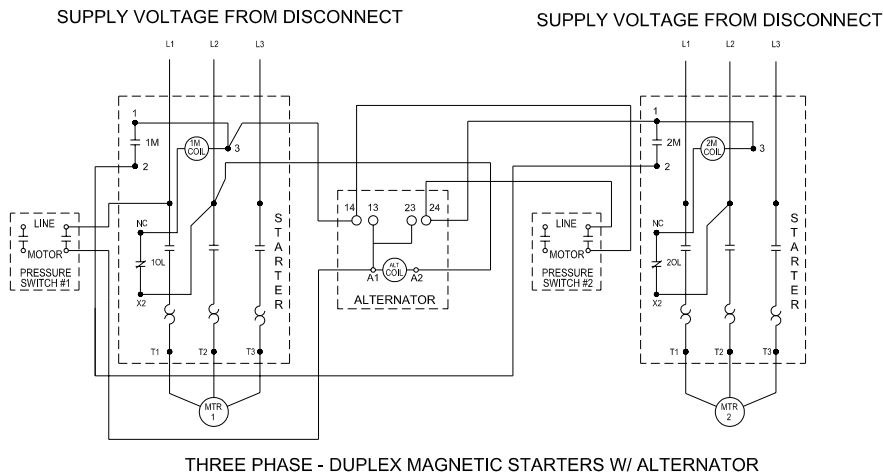

**B1258-A**  
(Ref. Drawing)

## INSTALLATION (CONT'D)



### CAUTION

**Wiring must be such that when viewing compressor from opposite shaft end, rotation of shaft is clockwise as shown by arrow on guard. Wrong direction rotation for any length of time will result in damage to compressor.**

### GROUNDING INSTRUCTIONS

This product should be connected to a grounded, metallic, permanent wiring system, or an equipment-grounding terminal or lead on the product.

### AIR LINE PIPING

Connection to air system should be of the same size, or larger, than discharge pipe out of unit. The table gives recommended minimum pipe sizes. A union connection to the unit and water drop leg is recommended. Install a flexible connector between the discharge of the unit and the plant air piping. Plant air piping should be periodically inspected for leaks using a soap and water solution for detection on all pipe joints. Air leaks waste energy and are expensive.

**Minimum Pipe Sizes For Compressor Air Lines  
(Based on clean Smooth Schedule 40 Pipe)**

MODEL	25'	50'	100'	200'	300'
R30D	3/4" (1-1/4")	1" (1-1/4")	1" (1-1/4")	1" (1-1/2")	1" (1-1/2")

Values in ( ) are for duplex unit.



### WARNING

**Never use plastic pipe or improperly rated metal pipe. Improper piping material can burst and cause injury or property damage.**

## OPERATION

This compressor has been inspected, thoroughly tested and approved at the factory. For this unit to give long satisfactory service it must be installed and operated properly. This compressor has been designed for a 80%/ON – 20%/OFF duty cycle.

Simplex units have a pressure switch that senses changes in receiver pressure and automatically starts and stops the compressor at preset pressure limits. If the receiver pressure falls below the cut-in pressure setting of the pressure switch the compressor will run until the cut-out pressure setting of the pressure switch has been reached.

Duplex units have lead and lag pressure switches and an automatic alternating system to evenly distribute the load between the two compressors. The pressure switches sense changes in receiver pressure and automatically start and stop the compressor at preset pressure levels. If the receiver pressure falls below the cut-in pressure setting of the lead pressure switch but remains above the cut-in pressure setting of the lag pressure switch, only one compressor will run until receiver pressure reaches the cut-out pressure of the lead pressure switch. The next time the pressure in the receiver drops, the system automatically starts the compressor that was idle. If the receiver pressure falls below the cut-in pressure setting of the lag pressure switch, both compressors run until receiver pressure reaches the cut-out pressure setting of the lead pressure switch.

## OPERATION (CONT'D)

Units furnished with head unloaders are equipped with a needle valve, pilot valve and head unloaders to provide continuous run capabilities. The pilot valve acts as an automatic air switch allowing air to flow from the receiver to the head unloader mechanism, thus actuating it. To operate unit in continuous run, open needle valve located next to pilot valve. The pilot valve is now able to sense receiver pressure. When the receiver pressure reaches the cut-out pressure setting of the pilot valve, the pilot valve opens and air is released to the unloader mechanism. The compressor stops compressing air and runs unloaded until the cut-in pressure setting of the pilot valve has been reached. At this time air released from the unloader mechanism and the compressor starts compressing again. Continuous run is recommended if motor starts exceed 8 starts/hour.

### Initial Start Up

1. Inspect unit for any visible signs of damage that would have occurred in shipment or during installation.
2. Pull main disconnect switch to unit to assure that no power is coming into the unit. "Lock Out" or "Tag Out" switch. Connect power leads to start.



### WARNING

**Do not attempt to operate compressor on voltage other than that specified on order or on compressor motor.**

3. Check compressor oil level. Add oil as required. See "Compressor Oil Specifications" Section.  
**NOTE:** Do not mix oil type, weights or brands.
4. Activate main disconnect switch.
5. "Jog" motor and check for proper rotation by direction arrow. If rotation is wrong, reverse input connections on the magnetic starter.
6. Close receiver outlet hand valve and start.
7. With receiver hand valve closed, let machine pump up to operating pressure. At this stage the automatic controls will take over. Check for proper cycling operation.
8. Check for proper operation of any options. Refer to individual option instruction sheet.
9. When the initial run period has shown no operating problems, shut unit down and recheck oil level.
10. Open receiver hand valve. The air compressor unit is now ready for use.



### WARNING

**This unit can start automatically without warning.**

## **GUIDE TO MAINTENANCE**

To obtain reliable and satisfactory service, this unit requires a consistent preventive maintenance schedule. Maintenance schedule pages are included in the back of this manual to aid in keeping the proper records.



### **WARNING**

**Before performing any maintenance function, switch main disconnect switch to "off" position to assure no power is entering unit. "Lock Out" or "Tag Out" all sources of power. Be sure all air pressure in unit is relieved. Failure to do this may result in injury or equipment damage.**

### **DAILY MAINTENANCE**

1. Check oil level of both compressor and engine if so equipped. Add quality lubricating oil as required. See Section on "Oil Specifications".
2. Drain moisture from tank by opening tank drain valve located in bottom of tank. Do not open drain valve if tank pressure exceeds 25 PSIG.
3. Turn off compressor at the end of each day's operation. Turn off power supply at wall switch.

### **WEEKLY MAINTENANCE**

1. Clean dust and foreign matter from cylinder head, motor, fan blade, air lines, intercooler and tank.
2. Remove and clean intake air filters.



### **WARNING**

**Do not exceed 15 PSIG nozzle pressure when cleaning element parts with compressed air. Do not direct compressed air against human skin. Serious injury could result. Never wash elements in fuel oil, gasoline or flammable solvent.**

3. Check V-belts for tightness. The V-belts must be tight enough to transmit the necessary power to the compressor. Adjust the V-belts as follows:
  - a. Remove bolts and guard to access compressor drive.
  - b. Loosen mounting hardware which secures motor to base. Slide motor within slots of baseplate to desired position.
  - c. Apply pressure with finger to one belt at midpoint span. Tension is correct if top of belt aligns with bottom of adjacent belt. Make further adjustments if necessary.
  - d. Check the alignment of pulleys. Adjust if necessary.
  - e. Tighten mounting hardware to secure motor on base.
  - f. Re-install guard and secure with bolts.



### **WARNING**

**Never operate unit without belt guard in place. Removal will expose rotating parts which can cause injury or equipment damage.**

## EVERY 90 DAYS OR 500 HOURS MAINTENANCE

1. Change crankcase oil. Use type and grade oil as specified in the section on "Compressor Oil Specifications".
2. Check entire system for air leakage around fittings, connections, and gaskets, using soap solution and brush.
3. Tighten nuts and capscrews as required.
4. Check and clean compressor valves, replace springs, discs and seats when worn or damaged.



### CAUTION

**Valves must be reinstalled in original position. Valve gaskets should be replaced each time valves are serviced.**

5. Pull ring on all pressure relief valves to assure proper operation.

## GENERAL MAINTENANCE NOTES

**PRESSURE RELIEF VALVE:** The pressure relief valve is an automatic pop valve. Each valve is properly adjusted for the maximum pressure permitted by tank specifications and working pressure of the unit on which it is installed. If it should pop, it will be necessary to drain all the air out of the tank in order to reseal properly. Do not readjust.

**TANK DRAIN VALVE:** Drain valve is located at bottom of tank. Open drain valve daily to drain condensation. Do not open drain valve if tank pressure exceeds 25 PSIG. The automatic tank drain equipped compressor requires draining manually once a week.

**PRESSURE SWITCH:** The pressure switch is automatic and will start compressor at low pressure and stop when the maximum pressure is reached. It is adjusted to start and stop compressor at the proper pressure for the unit on which it is installed. Do not readjust.

**BELTS:** Drive belts must be kept tight enough to prevent slipping. If belts slip or squeak, see V-belt maintenance in preceding section.



### CAUTION

**If belts are too tight, overload will be put on motor and motor bearings.**

**COMPRESSOR VALVES:** If compressor fails to pump air or seems slow in filling up tank, disconnect unit from power source and remove valves and clean thoroughly, using compressed air and a soft wire brush. After cleaning exceptional care must be taken that all parts are replaced in exactly the same position and all joints must be tight or the compressor will not function properly. When all valves are replaced and connections tight, close hand valve at tank outlet for final test. Valve gaskets should be replaced each time valves are removed from pump.

## GENERAL MAINTENANCE (Cont'd.)

### CENTRIFUGAL UNLOADER AND UNLOADER PRESSURE RELEASE VALVE:

The centrifugal unloader is operated by two governor weights. It is totally enclosed and lubricated from the crankcase of the compressor. When compressor starts, the governor weights automatically open compressing the main spring, allowing the unloader pressure release valve to close. When the compressor stops, the main spring returns the governor weights to normal position opening the unloader pressure release valve and unloading the compressor. This prevents overloading the motor when starting. If air continues to escape through the governor or unloader pressure release valve while operating, this is an indication that the unloader pressure release valve is not closing tightly and may be held open by foreign substance which has lodged on the seat. In order to correct this, remove the governor release valve cap, giving access to unloader pressure release valve spring and ball. Clean thoroughly and return parts in the same order in which they were removed. Loose drive belts can also cause unloader to leak by preventing the compressor from reaching proper speed. (See "BELTS" above).

**CHECK VALVE:** The check valve closes when the compressor stops operating, preventing air from flowing out of the tank through the pressure release valve. After the compressor stops operating, if air continues to escape through the release valve, it is an indication that the check valve is leaking. This can be corrected by removing check valve and cleaning disc and seat. If check valve is worn badly, replace same.



#### WARNING

**Before removing check valve be sure all air is drained out of tank and power is disconnected. Failure to do so may result in injury or equipment damage.**

**THE INTERSTAGE PRESSURE RELIEF VALVE** is provided to protect against interstage over pressure and is factory set for maximum pressure of 75 PSIG. **DO NOT RESET**  
If the pressure relief valve pops, it indicates trouble. Shut down the unit immediately and determine and correct the malfunction. Inspect the head valves. Serious damage can result if not corrected and can lead to complete destruction of the unit. Tampering with the interstage pressure relief valve, or plugging the opening destroys the protection provided and voids all warranty.

**COMPRESSOR LUBRICATION:** Fill crankcase to proper level as indicated by oil sight gauge. Keep crankcase filled as required by usage. It is recommended that only Champlub recip lubricant be used. This is a 30-weight, non-detergent industrial oil with rust and oxidation inhibitors specially formulated for reciprocating compressors. Do not mix oil types, weights or brands.

**MOTOR LUBRICATION:** Long time satisfactory operation of an electric motor depends in large measure on proper lubrication of the bearings. Bearing grease will lose its lubricating ability overtime, not suddenly. Refer to the motor manufacturer's instructions for the type of grease and lubrication intervals.

**PILOT VALVE:** The pilot valve actuates the head unloader mechanism to provide a means of stopping or starting the compression of air by the compressor without stopping or starting the electric motor.

## COMPRESSOR PILOT VALVE PRESSURE ADJUSTMENT

Proceed with the following instructions while compressor is running:

1. Loosen locknut (4) and back off several turns. Do not turn differential pressure adjustment nut (3).
2. Check reading on the tank pressure gauge. Set the compressor maximum pressure by turning threaded cap (1) clockwise to increase pressure or counter clockwise to decrease pressure. Pressure setting must be 5 psig less than setting of pressure switch.
3. After pressure is set, tighten locknut (4). Be careful not to move threaded cap (1).

## COMPRESSOR PILOT VALVE DIFFERENTIAL PRESSURE ADJUSTMENT

Proceed with the following instructions while compressor is running:

1. Loosen locknut (2) and back off several turns.
2. Check reading on the tank pressure gauge. Set the pressure to 30 psig differential (unload at 170 psig, reload at 140 psig). Turn nut (3) clockwise to increase differential pressure or counterclockwise to decrease differential pressure.
3. After pressure is set, tighten locknut (2). Be careful not to move nut (3).

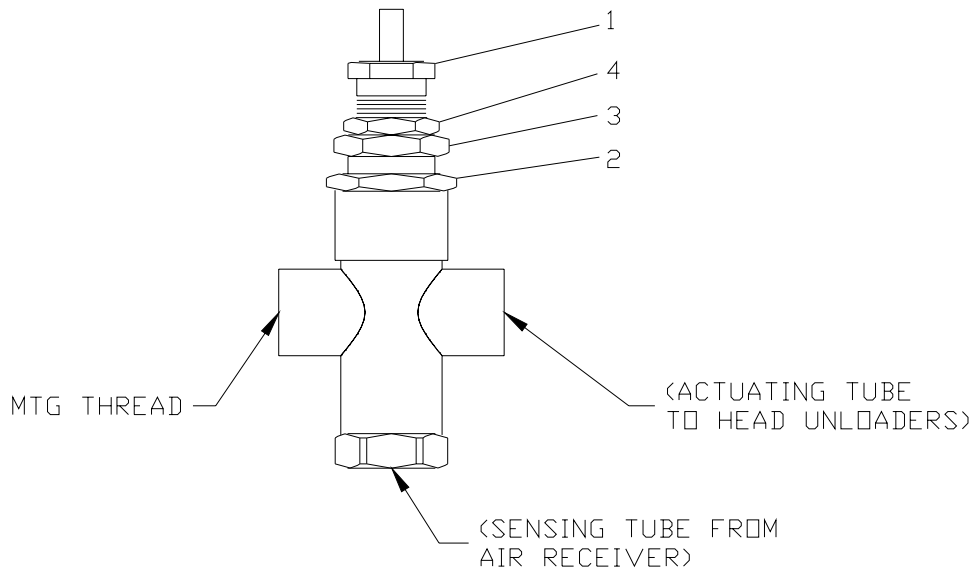



**B890-B**  
**(Ref. Drawing)**

## **COMPRESSOR OIL SPECIFICATIONS**

Compressors are factory filled with AEON hydrocarbon based recip lubricant. This is an ISO 100 non-detergent industrial lubricant with rust and oxidation inhibitors specially formulated for reciprocating compressors. It is recommended this compressor be maintained using this oil for ambient temperatures above 32°F.

AEON synthetic is a premium grade diester based synthetic lubricant providing excellent performance in high temperature applications.

 <b>CAUTION</b>
<b>Do not mix oil types, weights or brands.</b>

 <b>CAUTION</b>
<b>“Emulsification of oil (white milky substance) indicates unsafe accumulation of moisture and may be evidence compressor is oversized for application. Failure to promptly consult your local distributor, or Gardner Denver Customer Service, can be grounds to deny warranty.”</b>

### **NOTES:**

1. Normal break-in period of Gardner Denver air compressors is 25 hours.
2. For the first 100 hours of compressor operation, a careful and regular check of the oil level should be made. Maintain oil level at the full line.

### **CHANGING TO SYNTHETIC LUBRICANT**

(Applies to diester based synthetic lubricant only)

If changing to synthetic lubricant, the following steps must be completed.

1. Compressor must run for a 25 hour break-in period using AEON ISO 100 oil.
2. Thoroughly drain existing oil from crankcase.
3. Fill crankcase with a full charge of synthetic lubricant.
4. Run compressor for 200 hours.
5. Stop compressor and thoroughly drain the synthetic lubricant.
6. Add a full charge of synthetic lubricant.
7. Compressor now ready to run for extended period before next lubricant change made. Maintain oil level at the full line.

### **LUBRICANT**

AEON	
DESCRIPTION	PART NUMBER
1 – Quart Case (12/case)	28H213
1 – Gallon Case (4/case)	28H212
5 – Gallon Pail	28H211
55 – Gallon Drum	28H210
AEON SYNTHETIC	
DESCRIPTION	PART NUMBER
1 – Quart Case (12/case)	28H216
1 – Gallon Case (4/case)	28H215
5 – Gallon Pail	28H214

### **TORQUE VALVES**

SPECIFIC APPLICATION	FASTENER SIZE & THREAD	TORQUE	INCH-POUNDS
BEARING HOUSING BOLT	7/16 – 20		550
CYLINDER FLANGE BOLT	7/16 – 20		400
CONNECTING ROD BOLT	5-16 – 18		230
MANIFOLD BOLT	3/8 – 16		200
FLYWHEEL BOLT	1/2 – 13		600



## TROUBLE SHOOTING CHART FOR COMPRESSOR



### WARNING

Always disconnect unit from power supply and relieve all pressure from air tank before performing any maintenance. Failure to do so may result in equipment damage or injury. A Lock Out" or "Tag Out" all power sources.

Never operate unit without belt guard in place.

Never use gasoline or flammable solvent on or around compressor unit. Explosion may result.

### Troubleshooting Chart

Symptom	Possible Cause(s)	Corrective Action
Motor will not start.	<ol style="list-style-type: none"> <li>1. Main switch and fuses open.</li> <li>2. Starter heater coils open.</li> <li>3. Starter tripped</li> <li>4. Defective pressure switch-contacts will not close</li> <li>5. Low voltage.</li> </ol>	<ol style="list-style-type: none"> <li>1. Check all fuses and switches. Check for loose or faulty wires.</li> <li>2. Check overload relay in starter. Reset starter.</li> <li>3. Reset starter. If starter trips repeatedly, have electrical system inspected by an electrician.</li> <li>4. Repair or replace pressure switch.</li> </ol> <p> <b>Warning</b> – Relieve tank pressure before servicing.</p> <ol style="list-style-type: none"> <li>5. Check with voltmeter. Be sure voltage corresponds to unit specifications.</li> </ol>
Starter trips repeatedly.	<ol style="list-style-type: none"> <li>1. Improperly adjusted pressure switch.</li> <li>2. Faulty check valve.</li> <li>3. Incorrect fuse size or magnetic starter heaters.</li> <li>4. Low voltage.</li> <li>5. Defective motor.</li> </ol>	<ol style="list-style-type: none"> <li>1. Adjust or replace.</li> </ol> <p> <b>Warning</b> – Relieve tank pressure before servicing.</p> <ol style="list-style-type: none"> <li>2. Clean or replace</li> </ol> <p> <b>Warning</b> – Relieve tank pressure before servicing.</p> <ol style="list-style-type: none"> <li>3. Be sure that fuses and heaters are properly rated.</li> <li>4. Check with voltmeter. Be sure voltage corresponds to unit specifications.</li> <li>5. Replace motor.</li> </ol>
Tank pressure builds up slowly.	<ol style="list-style-type: none"> <li>1. Air leaks.</li> <li>2. Dirty air filter.</li> <li>3. Defective compressor valves</li> </ol>	<ol style="list-style-type: none"> <li>1. Tighten fittings.</li> <li>2. Clean or replace.</li> <li>3. Install new valve plate assembly.</li> </ol>
Tank pressure builds up quickly.	<ol style="list-style-type: none"> <li>1. Excessive water in tank.</li> </ol>	<ol style="list-style-type: none"> <li>1. Drain tank.</li> </ol>
Discharge pressure relief valve pops off while compressor is running.	<ol style="list-style-type: none"> <li>1. Wrong pressure switch setting.</li> <li>2. Defective ASME relief valve.</li> </ol>	<ol style="list-style-type: none"> <li>1. Adjust to correct setting.</li> <li>2. Replace valve.</li> </ol> <p> <b>Warning</b> – Relieve tank pressure before servicing.</p>
Compressor will not unload (Units with head unloaders)	<ol style="list-style-type: none"> <li>1. Wrong pilot valve setting.</li> <li>2. Defective pilot valve.</li> <li>3. Lack of air to pilot valve..</li> </ol>	<ol style="list-style-type: none"> <li>1. Adjust to correct setting</li> <li>2. Replace pilot valve.</li> <li>3. Open needle valve to pilot valve.</li> </ol>
Excessive belt wear.	<ol style="list-style-type: none"> <li>1. Pulley out of alignment.</li> <li>2. Belts too tight or too loose.</li> </ol>	<ol style="list-style-type: none"> <li>1. Realign motor pulley.</li> <li>2. Adjust belt tension.</li> </ol>
Compressor runs hot.	<ol style="list-style-type: none"> <li>1. Improper flywheel rotation</li> <li>2. Defective compressor valves.</li> <li>3. Dirty air filter.</li> <li>4. Dirty cylinder and/or intercooler.</li> </ol>	<ol style="list-style-type: none"> <li>1. Check for correct rotation. (Counter clockwise when viewed from drive side.</li> <li>2. Install new valve plate assembly.</li> <li>3. Clean or replace.</li> <li>4. Clean cylinder fins and/or intercooler.</li> </ol>
Interstage pressure relief valve pops off.	<ol style="list-style-type: none"> <li>1. Defective compressor valves.</li> </ol>	<ol style="list-style-type: none"> <li>1. Install new valves.</li> </ol>
Excessive oil consumption.	<ol style="list-style-type: none"> <li>1. Dirty air filter.</li> <li>2. Wrong oil viscosity.</li> <li>3. Oil leaks.</li> <li>4. Worn piston rings.</li> <li>5. Scored cylinder</li> </ol>	<ol style="list-style-type: none"> <li>1. Clean or replace.</li> <li>2. Refill with proper viscosity oil.</li> <li>3. Tighten bolts. Replace gaskets.</li> <li>4. Replace rings.</li> <li>5. Replace cylinder.</li> </ol>

## Troubleshooting Chart (Cont'd)

Symptom	Possible Cause(s)	Corrective Action
Air escapes from centrifugal unloader when unit is running	1. Centrifugal unloader release valve dirty or defective.	1. Clean or replace valve
Air escapes from centrifugal unloader when unit is stopped.	1. Check valve stuck in open position.	1. Replace check valve.   <b>Warning</b> – Relieve tank pressure before servicing.
System does not alternate (Duplex units only)	1. Starter tripped. 2. Loose wiring in alternator. 3. Defective alternator. 4. Defective motor.	1. Reset starter. If starter trips repeatedly, have electrical system inspected by an electrician. 2. Check and tighten all wiring connections. 3. Replace alternator. 4. Replace motor.

# PARTS ILLUSTRATION

MODELS: HR7-8, HR7-12, HR10-8, HR10-12, HR10-25, HR15F-8, HR15F-12 & HR15F-25

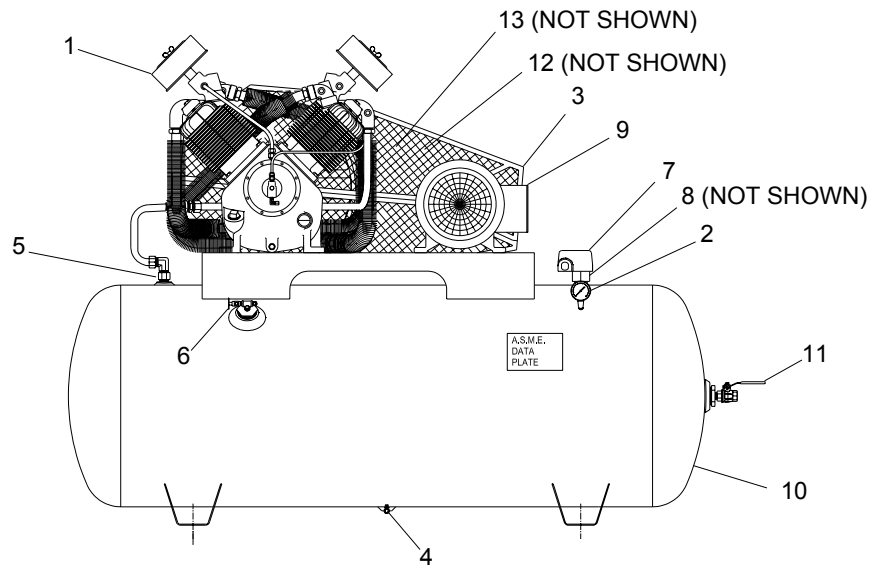

**C477-A**  
(Ref. Drawing)

## REPAIR PARTS LIST

### MODELS

	HR7-8	HR7-12	HR10-8	HR10-12	HR10-25	HR15F-8	HR15F-12	HR15F-25
1. Pump	R30D	R30D	R30D	R30D	R30D	R30D	R30D	R30D
2. Pressure Gauge	M519C	M519C	M519C	M519C	M519C	M519C	M519C	M519C
3. Belt Guard	CC1010951	CC1010951	CC1010951	CC1010951	CC1010951	CC1010951	CC1010951	CC1010951
4. Drain Valve	VP1022988	VP1022988	VP1022988	VP1022988	VP1022988	VP1022988	VP1022988	VP1022988
5. Check Valve	P05822A	P05822A	P05822A	P05822A	P05822A	P05822A	P05822A	P05822A
6. Bucket High Drain	Z1541	Z1542	Z1541	Z1542	Z1542	Z1541	Z1542	Z1542
7. Pressure Switch	125 PSIG	P14205A	P14205A	P14205A	P14205A	P14205A	P14205A	P14205A
	175 PSIG	P14202A	P14202A	P14202A	P14202A	P14202A	P14202A	P14202A
8. Pressure Relief Valve	M2843	M2843	M2843	M2843	M2843	M2843	M2843	M2843
9. Motor	7-1/2 HP	7-1/2 HP	10 HP	10 HP	10 HP	15 HP	15 HP	15 HP
10. Tank	P01400D	P01596D	P01400D	P01596D	P03564D	P01400D	P01596D	P03564D
11. Isolation Valve	CQM3756	CQM3756	CQM3756	CQM3756	CQM3756	CQM3756	CQM3756	CQM3756
12. Pulley	M7011D	M7011D	P11657A	P11657A	P11657A	P10718A	P10718A	P10718A
			PULLEY	PULLEY	PULLEY	PULLEY	PULLEY	PULLEY
175 PSIG	M2938	M2938	P05607A	P05607A	P05607A	P05622A	P05622A	P05622A
			BUSHING	BUSHING	BUSHING	BUSHING	BUSHING	BUSHING
13. Belts	B80 (2)	B80 (2)	B81 (2)	B81 (2)	B81 (2)	B85 (2)	B85 (2)	B85 (2)

**UNIT REPAIR PARTS ILLUSTRATION**  
**MODELS: VR7-8, VR7-12, VR10-8, VR10-12 & VR15F-12**

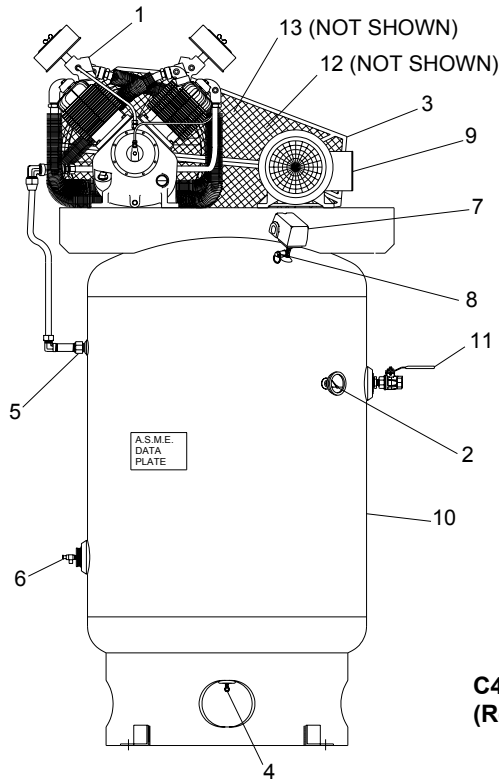

**REPAIR PARTS LIST**

**MODELS**

	VR7-8	VR7-12	VR10-8	VR10-12	VR15F-12
1. Pump	R30D	R30D	R30D	R30D	R30D
2. Pressure Gauge	M519C	M519C	M519C	M519C	M519C
3. Belt Guard	CC1010951	CC1010951	CC1010951	CC1010951	CC1010951
4. Drain Valve	VP1022988	VP1022988	VP1022988	VP1022988	VP1022988
5. Check Valve	P05822A	P05822A	P05822A	P05822A	P05822A
6. Bucket High Drain	Z1541	Z1541	Z1541	Z1541	Z1541
7. Pressure Switch	125 PSIG	P14205A	P14205A	P14205A	P14205A
	175 PSIG	P14202A	P14202A	P14202A	P14202A
8. Pressure Relief Valve	M2843	M2843	M2843	M2843	M2843
9. Motor	7-1/2 HP	7-1/2 HP	10 HP	10 HP	15 HP
10. Tank	P05944D	P02212D	P05944D	P02212D	P02212D
11. Isolation Valve	CQM3756	CQM3756	CQM3756	CQM3756	CQM3756
12. Pulley	125 PSIG	M7011D	M7011D	P11657A PULLEY P05607A BUSHING	P10718A PULLEY P05607A BUSHING
	175 PSIG	M2938	M2938	M2920	M2920
13. Belts	B80 (2)	B80 (2)	B81 (2)	B81 (2)	B85 (2)

**UNIT REPAIR PARTS ILLUSTRATION**  
**MODELS: HR7D-25, HR10D-25 & HR15DF-25**

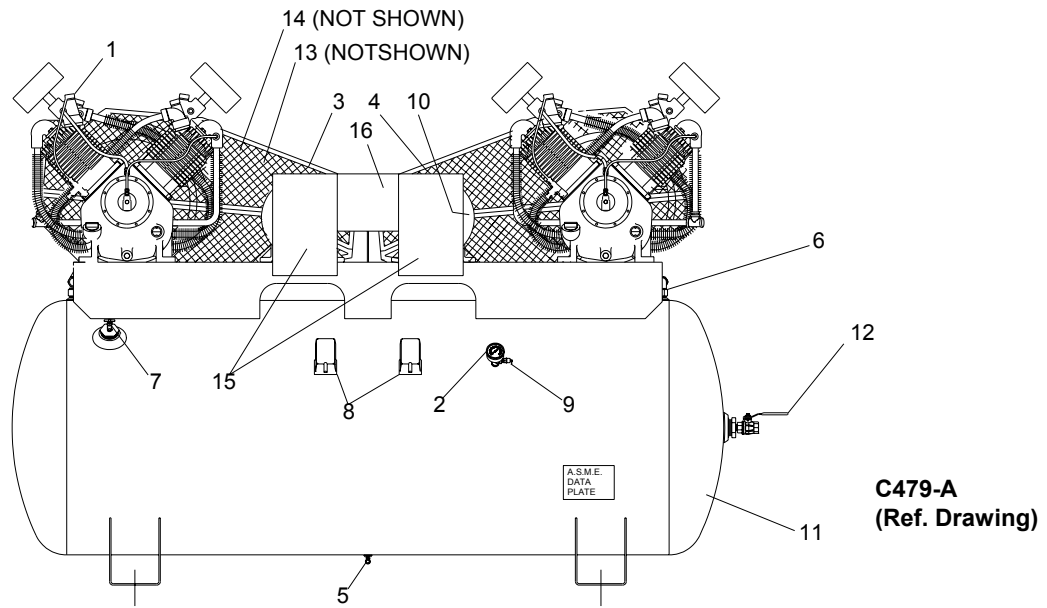

**REPAIR PARTS LIST4**

	<b>MODELS</b>					
	HR7D-12	HR7D-25	HR10D-12	HR10D-25	HR15DF-12	HR15DF-25
1. Pump	R30D	R30D	R30D	R30D	R30D	R30D
2. Pressure Gauge	M519C	M519C	M519C	M519C	M519C	M519C
3. Belt Guard	CC1010951	CC1010951	CC1010951	CC1010951	CC1010951	CC1010951
4. Belt Guard	CC1010956	CC1010956	CC1010956	CC1010956	CC1010956	CC1010956
5. Drain Valve	VP1022988	VP1022988	VP1022988	VP1022988	VP1022988	VP1022988
6. Check Valve	P05822A	P05822A	P05822A	P05822A	P05822A	P05822A
7. Bucket High Drain	Z1541	Z1542	Z1541	Z1542	Z1541	Z1542
8. Pressure Switch	125 PSIG	P14205A	P14205A	P14205A	P14205A	P14205A
	175 PSIG	P14202A	P14202A	P14202A	P14202A	P14202A
9. Pressure Relief Valve	M2843	M2843	M2843	M2843	M2843	M2843
10. Motor	7-1/2 HP	7-1/2 HP	10 HP	10 HP	15 HP	15 HP
11. Tank	P14129D	P05763D	P14129D	P05763D	P14129D	P05763D
12. Isolation Valve	CQM3756	CQM3756	CQM3756	CQM3756	CQM3756	CQM3756
*13. Pulley 125PSIG	M7011D (2)	M7011D (2)	P11657A	P11657A	P10718A	P10718A
			PULLEY (2)	PULLEY (2)	PULLEY (2)	PULLEY (2)
*13. Pulley 175 PSIG	M2938 (2)	M2938 (2)	P05607A	P05607A	P05622A	P05622A
			BUSHING (2)	BUSHING (2)	BUSHING (2)	BUSHING (2)
*13. Pulley 175 PSIG	M2938 (2)	M2938 (2)	M2920 (2)	M2920 (2)	P07981A	P07981A
					PULLEY (2)	PULLEY (2)
*13. Pulley 175 PSIG	M2938 (2)	M2938 (2)	M2920 (2)	M2920 (2)	P05622A	P05622A
					BUSHING (2)	BUSHING (2)
14. Belts	B80 (4)	B80 (4)	B81 (4)	B81 (4)	B85 (4)	B85 (4)
15. Starter	CONSULT FACTORY					
16. Alternator	CONSULT FACTORY					

**UNIT REPAIR PARTS ILLUSTRATION**  
**MODELS: BR7, BR10, & BR15F**

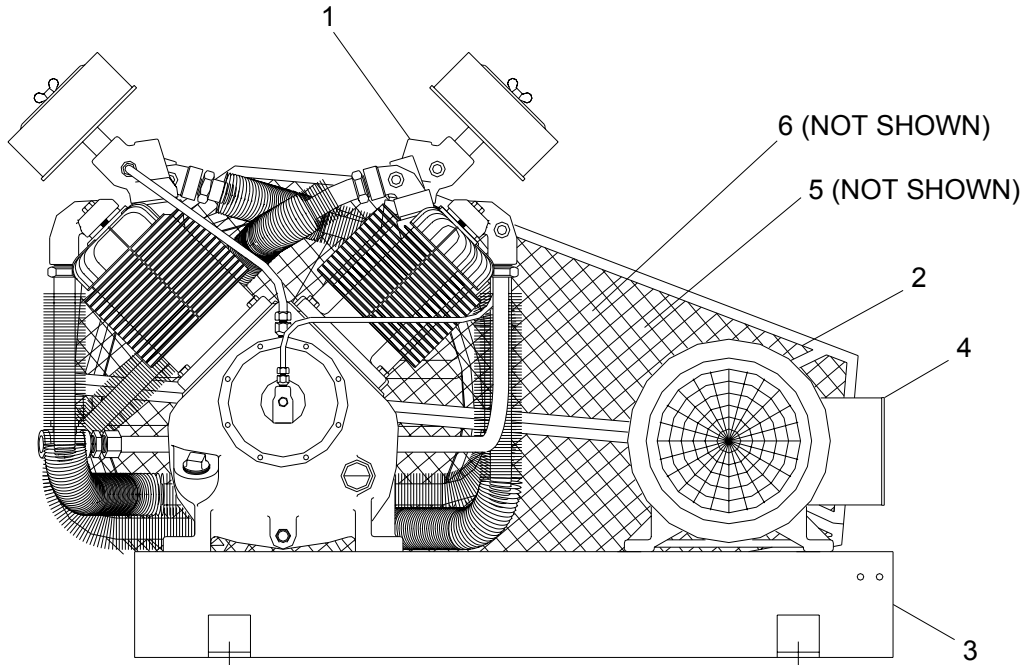

**C480-A**  
**(Ref. Drawing)**

**REPAIR PARTS LIST**

		<b>MODELS</b>		
		BR7	BR10	BR15F
1.	Pump	R30D	R30D	R30D
2.	Belt Guard	CC1010951	CC1010951	CC1010951
3.	Base Plate	P03970C	P03970C	P03970C
4.	Motor	7-1/2 HP	10 HP	15 HP
5.	Pulley 125 PSIG	M7011D	P11657A PULLEY P05607A BUSHING	P10718A PULLEY P05622A BUSHING
5.	Pulley 175 PSIG	M2938	M2920	P10718A PULLEY P05622A BUSHING
6.	Belts	B80 (2)	B81 (2)	B85 (2)

# Compressor Repair Parts Illustration

## Model: R30D

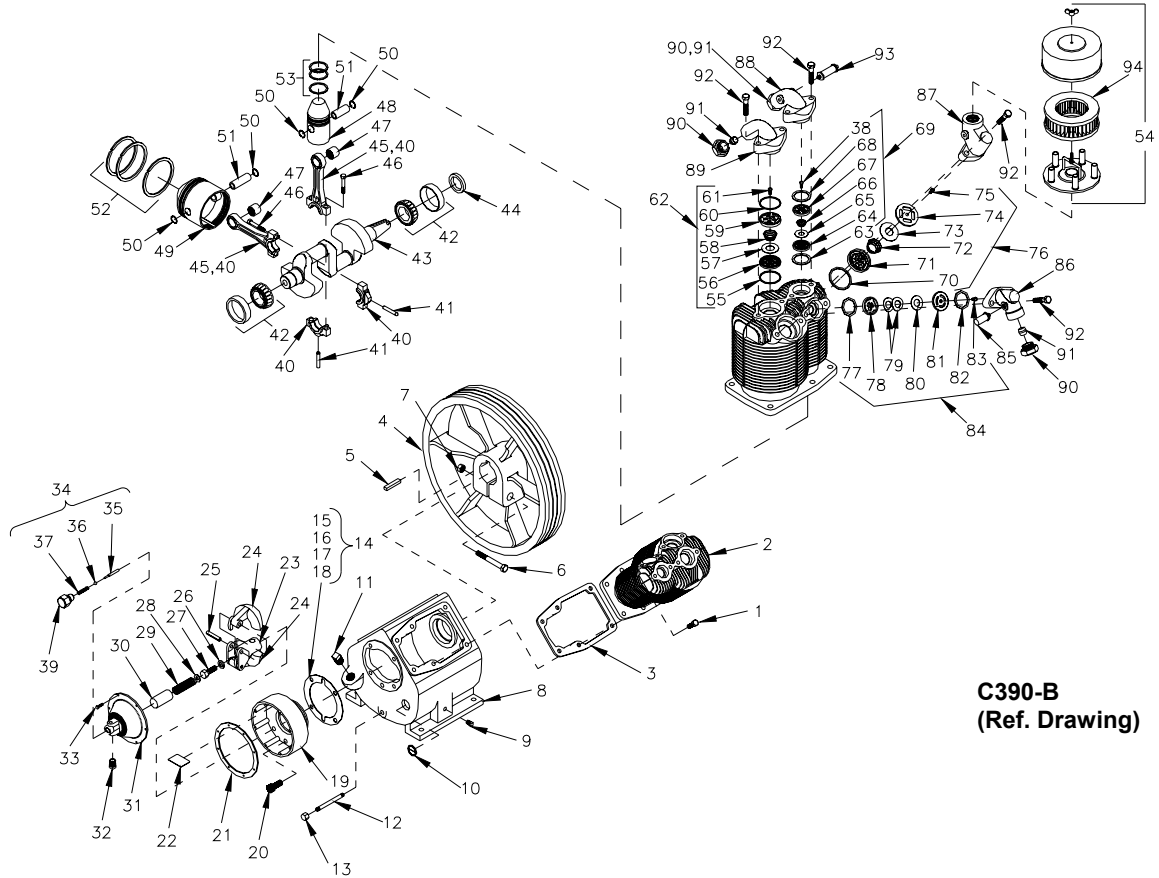

### Repair Parts List Compressor Model R30D

Ref. No.	Description	Part No.	Qty.
1	Hex head cap screw	M2345	12
2	Cylinder	P12237D	2
3	Cylinder flange gasket	NR29A	2
4	Flywheel	NR367B	1
5	Key	RE208	1
6	Hex head cap screw	M738	1
7	Hex nut	M2955	1
8	Crankcase	M1898	1
9	Pipe plug	64AA5	1
10	Oil level gauge	RE714	1
11	Pipe plug	64A5	1
12	Pipe nipple	M492	1
13	Pipe cap	M461	1
14	Governor housing gasket set (includes, 15, 16,17 & 18)	Z3030	1
15	Governor housing gasket (.032" Thick)	SE3030	1
16	Governor housing gasket (.005" Thick)	SE3030A	1
17	Governor housing gasket (.010" Thick)	SE3030B	1
18	Governor housing gasket (.015" Thick)	SE3030C	1
19	Governor housing	P12273C	1
20	Hex head cap screw	M3690	4
21	Governor housing cover gasket	SE489	1
22	Baffle plate	P12381A	1
23	Governor weight spindle	SE583B	1
24	Governor weight	SE582B	2
25	Governor weight pin	SE592A	2

**Repair Parts List  
Compressor Model R30D**

Ref. No.	Description	Part No.	Qty.
26	Lock washer	M3468	1
27	Hex head cap screw	M2345	1
28	Flat washer	M912A	1
29	Governor spring	SE590	1
30	Spring sleeve	SE587	1
31	Governor housing cover	RE10100A	1
32	Unloader muffler assembly	Z4593	1
33	Hex head machine screw	M3473	6
34	Release valve assembly	Z12414A	1
35	Release valve plunger	SE586B	1
36	Release valve ball	P07841A	1
37	Release valve spring	SE591	1
38	Hex head machine screw	M3220	2
39	Release valve body	NR101	1
40	Connecting rod assembly (includes items 41, 45, 46 & 47)	Z752	4
41	Oil dipper	R1024	4
42	Main Bearing	Z8981	2
43	Crankshaft	P12414B	1
44	Oil seal	OSN36A	1
45	Connecting rod (not sold separately)	---	--
46	Connecting rod bolt	M1583	8
47	Piston pin bearing	R1037	4
48	High pressure piston with pin (includes items 50 & 51)	ZP02709C	2
49	Low pressure piston with pin (includes items 50 & 51)	ZR154	2
50	Piston pin retaining ring	R10102	8
51	Piston pin	R1021	4
52	Low pressure piston ring set	Z798	2
53	High pressure piston ring set	Z797	2
54	Intake filter	P04999A	2
55	Valve gasket	P04135A	2
56	Discharge valve seat	M2097	2
57	Valve disc	RE1061	2
58	Valve spring	RE1059	2
59	Discharge valve cage	M2099	2
60	Valve gasket	P04135A	2
61	Hex head machine screw	M3220	2
62	Low pressure discharge valve assembly	Z813	2
63	Valve gasket	P04137A	2
64	Discharge valve seat	RE757A	2
65	Valve disc	RE1062	2
66	Valve spring	RE760	2
67	Discharge valve cage	M2100	2
68	Gasket, Valve, HPEX, R10-30	CQP14869A	2
69	High pressure discharge valve assembly	Z115	2
70	Gasket, Valve, LPIN, R10-30	CQP14832A	2
71	Intake valve cage	M2098	2
72	Valve spring	RE1458	2
73	Valve disc	RE1470	2
74	Intake valve seat	RE1471	2
75	Hex head machine screw	P04544A	2



**Repair Parts List  
Compressor Model R30D**

Ref. No.	Description	Part No.	Qty.
* 76	Low pressure intake valve assembly	Z812	2
77	Valve gasket	P09171A	2
78	Intake valve cage	P14224A	2
79	Valve spring	P13866A	4
80	Valve disc	P13865A	2
81	Intake valve seat	P14118B	2
82	Gasket, Valve, HPIN, R10-30	CQP14870A	2
83	Hex head machine screw	M3220	2
* 84	High pressure intake valve assembly	Z11937	2
85	Interstage pressure relief valve	M3685	2
86	High pressure intake manifold	P12302B	2
87	Low pressure intake manifold	P09669C	2
88	High pressure discharge manifold	P12303B	2
89	Low pressure discharge manifold	RE102E	2
90	Compression nut	SE541	6
91	Ferrule	SE542	6
92	Hex head cap screw	P05005A	16
93	Pressure relief valve	P09704A	1
94	Intake filter element	P05050A	2

	Complete compressor pump gasket set (items 3, 11, & 21)	Z10887	1
	Low pressure piston kit (items 49 & 52)	Z9101	2
	High pressure piston kit (items 48 & 53)	Z9100	2
	Complete compressor pump ring set (items 52 & 53)	Z9085	1
	Complete valve set w/gaskets	Z5157	1
	Complete valve gaskets set	Z5158	1

\* See page 27 for intake valves for head unloader pumps.  
Use Z6796 – Complete Valve Set for head unloader pumps.

**Compressor Repair Parts Illustration**  
**Model: R30D**

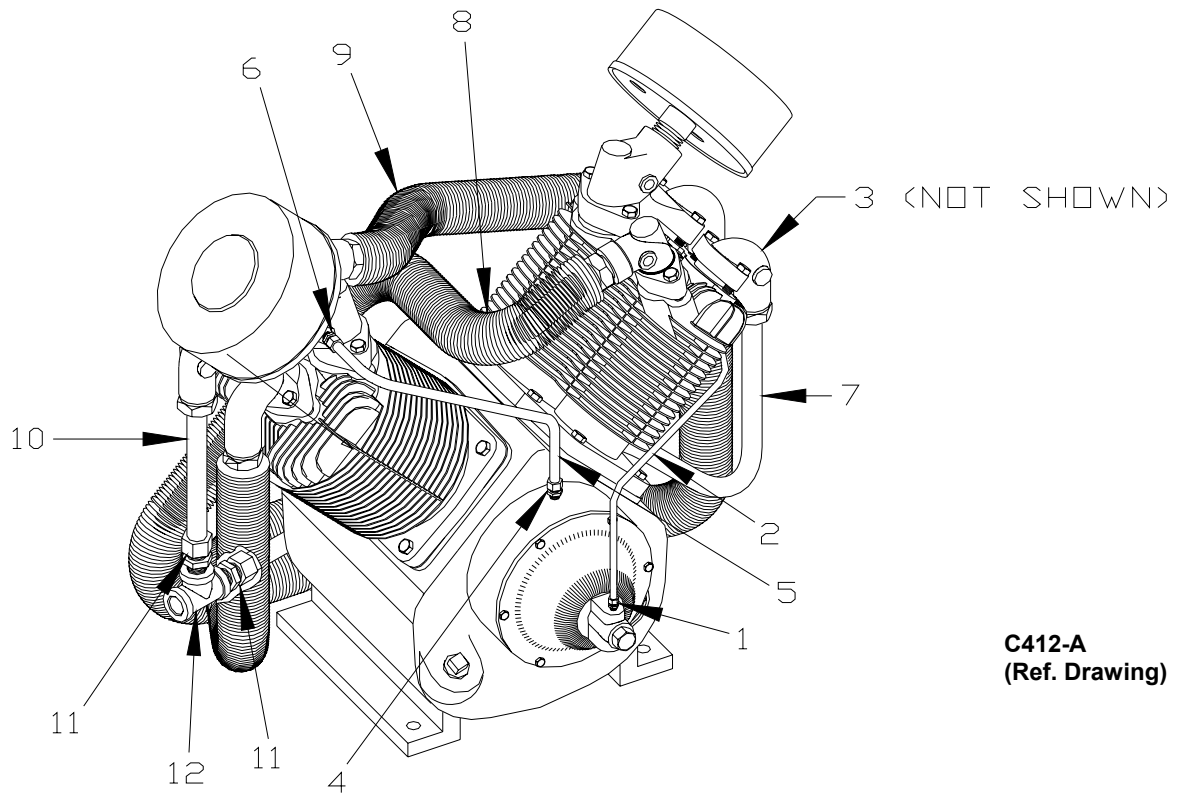

**C412-A**  
**(Ref. Drawing)**

**REPAIR PARTS LIST**  
**COMPRESSOR MODEL R30D**

Ref. No.1	Description	Part No.	Qty.
1	Tube Fitting	M2863	1
2	Release Valve Tube w/Fittings (Items 1 & 3)	ZP8133B	1
3	Tube Fitting	86A40	1
4	Tube Fitting	M2864	1
5	Breather Tube w/Fitting (Items 4 & 6)	ZUB375B	1
6	Tube Fitting	M2864	1
7	Tube, Discharge	ZP8132B	1
8	Intercooler Tube w/Fittings	Z9141	1
9	Intercooler Tube w/Fittings	Z9142	1
10	Tube, Discharge	ZM2474-8	1
11	Tube Fitting	M2867	2
12	Pipe Tee	M480	1

## CONSTANT SPEED HEAD UNLOADER For Air Compressor Model R30D

**NOTE:** This is optional equipment and may not be included on your unit.

The purpose of constant speed unloading is to provide a means of stopping or starting the compression of air by the compressor without stopping or starting the electric motor or gasoline engine after each cycle.

The parts called out below replace or are substituted for those found in the regular parts list.

### Repair Parts List for Constant Speed Head Unloader

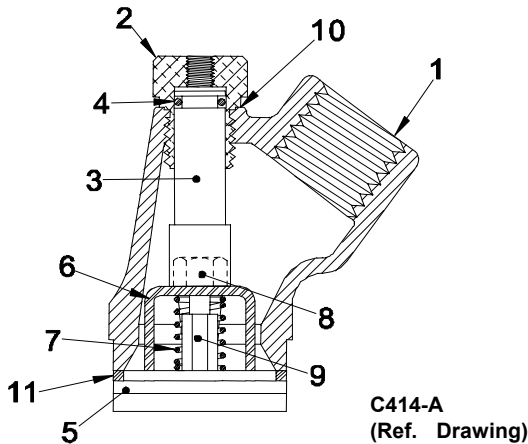

**TYPICAL MANIFOLD ASSEMBLY**

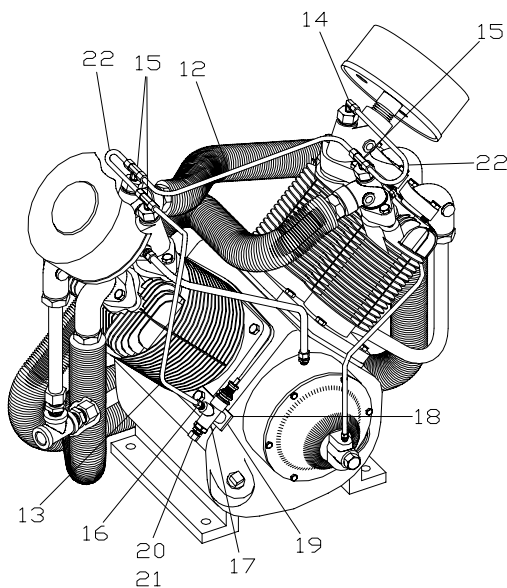

Low Pressure			
REF. NO.	DESCRIPTION	PART NO.	QTY.
1	LP Intake Manifold Group (includes 1,2,3,4)	Z6312	2
1	LP Intake Manifold	P09670C	2
2	Cylinder	P02306B	2
3	Unloader Piston	P09923A	2
4	O-Ring	P02547A	2
5	LP Valve Assembly (includes 6,7,8,9)	Z4877	2
6	Unloader Finger	P09085A	2
7	Unloader Spring	P09084A	2
8	Locknut	P09086A	2
9	Guide Stem	P09083A	2
High Pressure			
REF. NO.	DESCRIPTION	PART NO.	QTY.
	HP Intake Manifold Group (Includes items 1,2,3,4,10)	Z9143	2
1	HP Intake Manifold	P12304B	2
2	Cylinder	P02306B	2
3	Unloader Piston	P09923A	2
4	O-Ring	P02547A	2
5	HP Valve Assembly (includes 6,7,8,9 & 11)	Z11938	2
6	Unloader Finger	P14119A	2
7	Unloader Spring	P01882A	2
8	Locknut	P09086A	2
9	Guide System	P09296A	2
10	Cylinder Gasket	P00746A	2
11	Valve Gasket (not included)	P09171A	2
Low & High Pressure			
REF. NO.	DESCRIPTION	PART NO.	QTY.
12	Intermediate Tube	ZP08461B	1
13	Actuating Tube	ZP08463B	1
14	Compression Fitting	M2868	1
15	Compression Fitting	M2879	3
16	Compression Fitting	M2863	1
17	Pilot Valve	M2853	1
18	Mounting bracket	M807	1
19	Screw, Hex Head Cap	M3465	1
20	Compression Fitting	M2862	1
21	Sensing Tubing, 1/4" O.D. (Specify length)	M2474	---
22	Manifold Tube	Z9172	2
--	Needle Valve (Dual Control) Not Shown	M547	1
--	Constant Speed Head Unloader Kit (Includes all of the above)	Z9145	1

### UNIT HAZARD DECAL LISTING

<u>PAGE</u>	<u>DESCRIPTION</u>	<u>PART NO.</u>
29	PRODUCT LIABILITY DECAL SHEET - MASTER	P10157A
	Unit Pressure Setting	1
	NOT USED	2
	DANGER – Breathing Air	3
	DANGER – Drain Tank Daily	4
	WARNING – Pressure/Safety Valve	5
	NOT USED	6
	DANGER – Valve Maintenance	7
	DANGER – High Voltage	8
	WARNING – Hot Surfaces	9
	WARNING – Do Not Remove Fan Guard	10
	NOT USED	11a
	NOTICE - Lubricant	11b
	NOT USED	12
	DECAL – Synthetic or Food Grade Inserts	13
	DECAL – Pressure Setting: 95-125 PSIG	14
	DECAL – Pressure Setting: 140-175 PSIG	14
	NOTICE – Read and Retain Manuals	15
	NOT USED	16
	DECAL – Rotation Direction	17
	NOT USED	18
	DECAL – Pressure Switch	P14677A

### PUMP HAZARD DECAL LISTING

<u>PAGE</u>	<u>DESCRIPTION</u>	<u>PART NO.</u>
30	PUMP DECAL SHEET – MASTER	P13805A
	NOTICE - Lubricants	A1
	NOT USED	A2
	DECAL – Rotation Direction	B
	NOTICE – Read and Retain Manuals	C
	DANGER – Breathing Air	D
	DECAL – Made in the United States of America	E
	IMPORTANT NOTICE – Motor Burn-Outs	F

DO NOT CONNECT  
INCOMING POWER  
SUPPLY TO PRESSURE  
SWITCH.

P14677A

## UNIT HAZARD DECALS

**1**

**UNIT PRESSURE FACTORY SET AT**

**UNIT PRESSURE FACTORY SET AT**

**2**

**WARNING**

DO NOT START ENGINE UNLESS TANK PRESSURE IS BELOW 130 PSIG. TO REDUCE TANK PRESSURE, OPEN VALVE ADJACENT TO THIS DECAL.

**3**

**DANGER**

Air from this compressor must not be used for food processing or breathing without adequate filtering. Failure to comply will result in injury or death.

**4**

**DANGER**

**DRAIN THIS TANK DAILY!**

Failure to drain moisture will corrode tank material and lead to tank failure which will cause equipment damage, injury, or death.

**5**

**WARNING**

RELIEVE TANK PRESSURE BEFORE SERVICING. Failure to do so can result in injury. DO NOT ADJUST PRESSURE SWITCH, PILOT VALVE, OR SAFETY VALVES. Exceeding factory settings can cause equipment damage and injury.

**6**

MODEL: \_\_\_\_\_

SERIAL NO: \_\_\_\_\_

**7**

**DANGER**

Valves must be replaced in original position. Failure to do this will result in equipment damage, injury, or death. Do not disassemble valves.

**8**

**DANGER**

HIGH VOLTAGE

DISCONNECT POWER SOURCE BEFORE SERVICING.

**9**

**WARNING**

Do not touch hot surfaces! Contact with these surfaces can cause injury.

**10**

**WARNING**

DO NOT REMOVE BELT OR FAN GUARD

Removal will expose rotating parts which can cause severe injury and/or property damage.

**10**

**WARNING**

DO NOT REMOVE BELT OR FAN GUARD

Removal will expose rotating parts which can cause severe injury and/or property damage.

**11a**

**NOTICE**

YOUR COMPRESSOR HAS BEEN TESTED AND SHIPPED WITH

*ChampionLife*

FOR OPTIMUM PERFORMANCE USE ONLY GENUINE CHAMPION PARTS AND LUBRICANTS. CHAMPION DISTRIBUTOR FOR ADDITIONAL LUBRICANT AND REPLACEMENT PARTS.

**11b**

**NOTICE**

YOUR COMPRESSOR HAS BEEN TESTED AND SHIPPED WITH

**AFON**

FOR OPTIMUM PERFORMANCE USE ONLY GENUINE GARDNER DENVER PARTS AND LOCAL LUBRICANTS. GARDNER DENVER DISTRIBUTOR FOR ADDITIONAL LUBRICANT AND REPLACEMENT PARTS.

**12**

SYNTHETIC

FOOD GRADE

**13**

AC-SY

AC-HC

AC-FG

**14**

85-115 PSIG
95-125 PSIG
130-165 PSIG
140-170 PSIG
140-175 PSIG
215-250 PSIG
20-40 PSIG
60-80 PSIG
60-90 PSIG
70-90 PSIG
70-100 PSIG
80-100 PSIG

**15**

**NOTICE**

Read, understand and retain all labels and Owners Manuals before using this equipment. **IMPORTANT:** Please keep the operating Instructions with this compressor unit.

**16**

**INSTRUCTIONS**

**DUAL CONTROL**

This unit is equipped with a dual control valve. Open valve completely for continuous run operation. Close valve completely for start-stop operation.

**17**

**18**

RESET

RESET

Master Decal Set  
P/N P10157A

## PUMP HAZARD DECALS

**A1**

**A2**

**B**

**C**

**D**

**E**

**F** **IMPORTANT NOTICE!**

THIS UNIT IS WIRED FOR AN AC CIRCUIT OF

<input type="checkbox"/> 115 VOLT	<input type="checkbox"/> 60 CYCLE	<input type="checkbox"/> 1 PHASE
<input type="checkbox"/> 230 VOLT	<input type="checkbox"/> OTHER	<input type="checkbox"/> 3 PHASE
<input type="checkbox"/> 460 VOLT		

OTHER ELECTRICAL SPECS \_\_\_\_\_

P05257A

**IMPORTANT**

MOTOR BURN-OUTS ARE NOT COVERED BY WARRANTY - Unless Motor is Equipped with Factory Installed thermal overload protection (in either motor or starting device)

P05257A





\*GF3233VER10\*



Copyright © 2008 Gardner Denver, Inc.  
Printed in U.S.A.

Gardner Denver  
1301 North Euclid Avenue  
Princeton, Illinois 61356 USA  
Phone (815) 875-3321  
Fax (815) 872-0421

[www.gardnerdenver.com](http://www.gardnerdenver.com)

Plants in Princeton, IL, and Manteca, CA

Due to Gardner Denver's continuing product development program,  
specifications and materials are subject to change without notice or obligation

