

Parts List			
ITEM	PART NUMBER	QTY	DESCRIPTION
1	3822-8	2	SOLID HDEP NEXT CUSTOMER BAR
2	77350	1	Label, Warranty, Wal-Mart
3	BM-56310-L	1	ASSY, CASHSTAND LH
4	BM-56478-8-LH	1	Assy, 8' Conveyor -LH
5	BM-58454	1	SPOTWELD, SHELF
6	BM-58810-LH	1	Carousel, 6-Bag -LH
7	BM-62982-LH	1	Kit, Accessory LH Wal-Mart

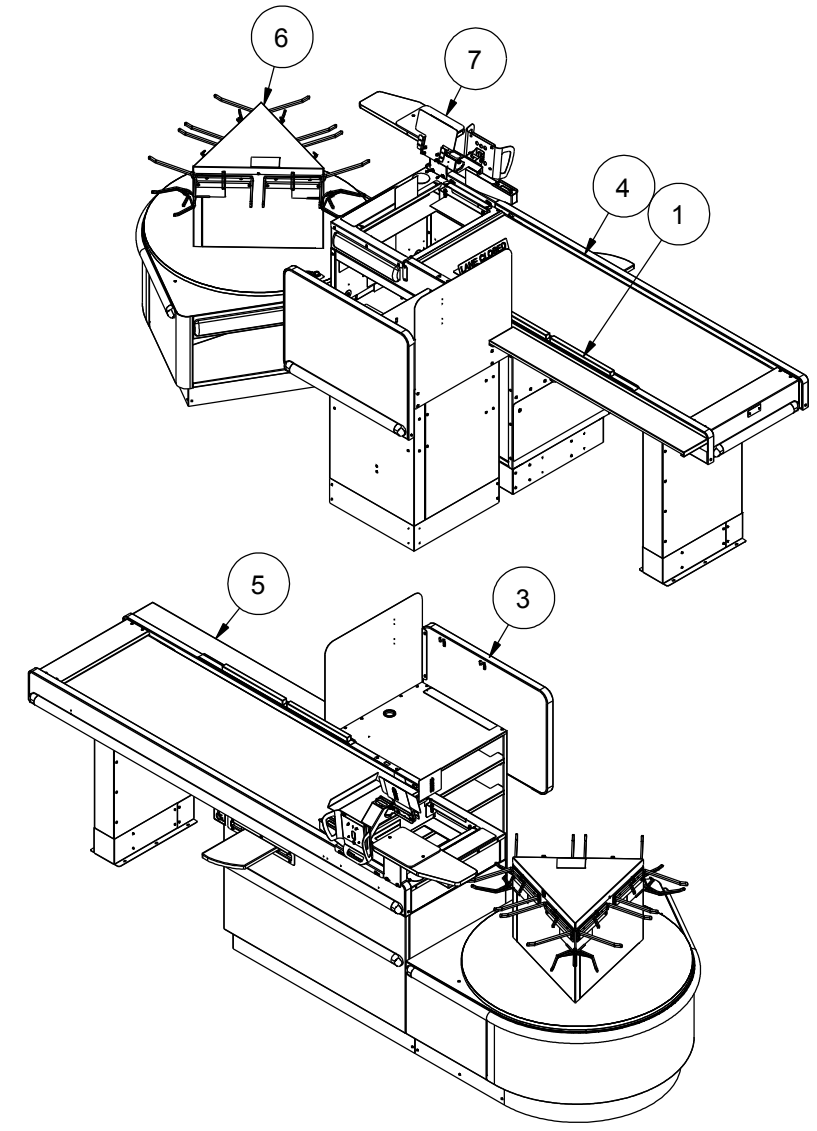

The contents of this drawing are the exclusive property of Pan-Oston, and are for the use of the customer for whom they were created. Any reproduction or disclosure thereof without the written consent of Pan-Oston, is strictly prohibited.

REVISION HISTORY			
REV	DESCRIPTION	DATE	APPROVED
2	DCR #900197	1/7/2010	DAS
DRAWN Glen Shirley		6/16/2009	ALL DIMENSIONS ARE IN MILLIMETERS, ANSI Y14.5 ST. STL. PARTS PAPERSIDE UP UNLESS OTHERWISE NOTED FIRST ANGLE PROJ.
CHECKED			
OPPOSITE DWG M-30299-8-RH		DESCRIPTION: 8ft CAROUSEL CHECKOUT LANE MATERIAL	DWG NO M-30299-8-LH TITLE:
REFERENCE DWG M-30261-8-LH			
PAINT ZONE		Pan-Oston SHEET 1 OF 2	