

# R5-R10 RACK n ROLL

## Service Manual



# **TABLE OF CONTENTS**

<b>INTRODUCTION .....</b>	<b>4</b>
Hours Counter .....	5
Serial Numbers Explained.....	5
<b>SAFETY</b>	
Important Safety Instructions .....	6
<b>SAFETY.....</b>	<b>7</b>
Safety Hazards.....	7
<b>PREPARATIONS</b>	
Electrical Specifications .....	8
Grounding Instructions.....	8
Grounding Instructions.....	9
Building Requirements .....	9
<b>FEATURES &amp; SPECIFICATIONS.....</b>	<b>10</b>
<b>ABOUT RACK n ROLL.....</b>	<b>11</b>
<b>OPERATING INSTRUCTIONS</b>	
Operating the R10R.....	12
212e Keypad .....	15
212e Keypad .....	16
Resetting IEI (stainless steel plate) keypad .....	17
Visonic Keypad.....	18
In use until July 2000 .....	18
Changing Code:.....	18
<b>TROUBLESHOOTING .....</b>	<b>19</b>
<b>R5-R10 COMPONENTS MANUAL.....</b>	<b>28</b>
<b>ELECTRICAL COMPONENTS .....</b>	<b>29</b>
<b>CUTTER DRIVE COMPONENTS.....</b>	<b>31</b>
<b>CUTTER COMPONENTS.....</b>	<b>33</b>
<b>CIRC CUTTER COMPONENTS .....</b>	<b>35</b>
<b>CUTTER BLOCK COMPONENTS .....</b>	<b>37</b>
<b>CIRC CUTTER DRIVE COMPONENTS .....</b>	<b>39</b>
<b>ROLLER DRIVE COMPONENTS .....</b>	<b>43</b>
<b>HOLD DOWN &amp; PINCH ROLLER COMPONENTS.....</b>	<b>44</b>
<b>COUNTER COMPONENTS .....</b>	<b>45</b>
<b>MISC COMPONENTS.....</b>	<b>46</b>

# **TABLE OF CONTENTS**

**CONTROL COMPONENTS .....48**

**ROLLER DRIVE COMPONENTS .....50**

    Pinch Roller Latch Preventative Maintenance ..... 53

    RnR CHDB Front Pivot Bolt Retrofit..... 54

    Steps to install the front cutter pivot bolt retrofit kit..... 55

**UPDATE KITS**

    Changes by Serial Number R5 - R6 ..... 57

    Changes by Serial Number R6 - 07/10/2000 ..... 58

    Changes by Serial Number R6 - R7 ..... 59

    Flap Disc Sharpener Update Kit (optional) ..... 60

    R3 - R7 Latch Kit ..... 61

    Pinch Roller Centre Support..... 62

    Pinch Roller Centre Support (con't) ..... 63

**WIRING SCHEMATIC .....64**

**WARRANTY & LIABILITY**

    Vidir Machine Inc. Warranty Agreement and Limitation of Liability..... 76

# INTRODUCTION

This machine has been carefully designed and constructed to provide you with many years of dependable service. It has been built to meet or exceed current UL or CSA standards. With proper care in operation and maintenance, this machine will assist you in maximizing your efficiency.

To ensure the utmost value and performance from your machine, please read this manual carefully to be sure correct operation procedures are followed.

This manual provides you with operation, troubleshooting, and maintenance procedures for your machine. However, if help is needed or if any of these procedures are unclear, please contact Vidir at 1-800-210-0141.

## SERIAL NUMBER

Please be sure to record the serial number for any future service calls and parts ordering.

Serial No. \_\_\_\_\_

## IMPORTANT CAUTION NOTICE:

Vidir has made every effort to protect operators and others from injury due to mechanical parts movement and electrical safety. As with any mechanical device, the operator is responsible to inspect the condition of the machine prior to use and adhere to safe operating procedures at all times.

A factory approved Preventative Maintenance is recommended every 12 months or 100 hours, whichever comes first.

Information in this document is proprietary, confidential, and property of Vidir Machine Inc. Disclosure or duplication of this material is prohibited except by authorization of Vidir Machine Inc.

**service@vidir.com**

**Head Office**  
**Vidir Machine Inc.**  
 Box 700  
 Arborg, Manitoba, Canada  
 R0C 0A0  
 Service: 1-866-821-2647  
 Toll Free: 1-800-210-0141  
 Phone: 1-204-364-2442  
 Fax: 1-204-364-2454  
 Service Fax: 1-204-364-3072

**U.S. Office**  
**Vidir Inc.**  
 19 East Lehman St.  
 Lebanon, PA  
 17046 USA  
 Service: 1-866-821-2647  
 Toll Free: 1-866-898-4347  
 Phone: 1-717-270-1000  
 Fax: 1-717-270-1001



# INTRODUCTION

## Hours Counter

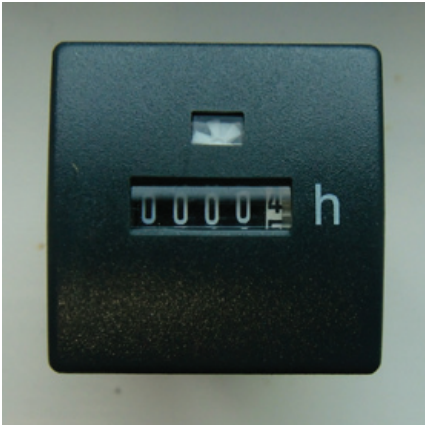

Vidir has installed an hour counter into our machine products. This counter will assist you to determine when Preventative Maintenance is to be scheduled (100 hours of machine use, or 12 months, whichever comes first).

Please contact Vidir Service for additional information on this feature.

## Serial Numbers Explained

Example: R10RL-13-1

R-Rack and Roll

10-Model Series

R-rotary cutter

L-17' machine vs 15'

13 - year of manufacture

1- sequential serial number

## Serial Numbers Explained

Example: R8RL-0702-1389

R-Rack and Roll

8-Model Series

R-rotary cutter

L-17' machine vs 15'

0702-month & year of manufacture

1389- sequential serial number

# **SAFETY**

## **Important Safety Instructions**

Read this manual carefully to ensure familiarity with the controls and the proper use of the equipment.

The warnings and precautions contained in this manual **DO NOT** cover all potential dangers, and hazards that may be encountered.

This manual is intended to provide basic safety guidelines for proper operation, maintenance, and servicing of the machine.

### **WARNING – Risk of injury**

- Installation and service of this machine should be performed by qualified service personnel.
- Only properly trained service personnel should have access to the interior components of the machine.
- Electrical connections should be performed by qualified electricians.
- Operation must be performed by trained personnel. Never allow children or unauthorized persons to operate the machine.
- **DO NOT** post the security password where unauthorized users will have access to it.

### **DANGER – To reduce the risk of electrical shock:**

- Keep cord away from heated surfaces or areas where it can be easily damaged.
- Do not change current limit ratings of overload protectors. For further instruction please contact our service line.
- Turn all switches to the off position and disconnect power to the machine before cleaning, maintenance, or repairs.
- Risk of electrical shock – Connect this machine to a properly grounded outlet only. See grounding instructions.
- Keep the area of operation clear of all persons and potential hazards.
- Always shut off the main power switch before servicing the machine.
- Keep all guards and shields in place

Use this machine only for its intended purpose as described by these instructions.

Do not use attachments not recommended or approved by the manufacturer.



Never operate this machine if it has been damaged, has a damaged electrical cord, or if it is not working properly. Keep all guards and shields in place.

Keep area clean and organized during operation.

**For further instruction please contact our service line.**

# SAFETY

## Safety Hazards

	Safety Hazard - Entanglement	- Loose clothing or jewelry could become entangled or drawn in
	Safety Hazard - Crushing/Rolling	- Material roll may present a hazard of crushing or rolling over toes or hands when loading or unloading machine.
	Safety Hazard - Heavy Lifting	- Use proper lifting technique, and additional help to load material roll onto wall rack.

Cease all operation and lock out machine in any case where the machine is not operating as designed and call Vidir Service.

# **PREPARATIONS**

## **Electrical Specifications**

Machine Power Requirements: Please see machine label for electric power requirements.

### **FEATURES:**

This machine is equipped with a Master Switch. This switch is highly visible and easy to reach. It shuts off all power to the machine. Ensure the Master Switch is in the OFF position before working on the machine, to prevent accidental operation of the machine.

### **NOTE:**

All relays and transformers are located in the electrical box behind the control panel. These can be accessed by removing the screws that secure the control panel cover to the box. Ensure the Master Switch is in the OFF position before removing the control panel.

### **CAUTION:**

If the motors start to overload and stop during the operation of the machine remove pressure from the Push Button. Do not try to force the machine. Do not continue to activate and deactivate an overloaded motor. This will cause excessive wear and motor overheating. Correct the load conditions on the machine before trying again.

### **ATTENTION:**

The machine should have a dedicated circuit.

## **Grounding Instructions**

This product must be grounded. If it should malfunction or break down, grounding provides a path of least resistance for electric current to reduce the risk of electric shock. This product is equipped with a cord having an equipment-grounding conductor and a grounding plug. The plug must be plugged into an appropriate outlet that is properly installed and grounded in accordance with all local codes and ordinances.

**DANGER** – Improper connection of the equipment-grounding conductor can result in a risk of electric shock. Check with a qualified electrician or service person if you are in doubt as to whether the product is properly grounded.

Do not modify the plug provided with the product. If it will not fit the outlet, have a proper outlet installed by a qualified electrician or service person.

This product must be connected to a grounded metal, permanent wiring system, or an equipment-grounding conductor must be run with the circuit conductors and connected to the equipment-grounding terminal or lead on the product.



# **PREPARATIONS**

## **Grounding Instructions**

This product is factory-equipped with a specific electric cord and plug to permit connection to a proper electric circuit. Make sure that the product is connected to an outlet having the same configuration as the plug. No adapter should be used with this product. If the product must be reconnected for use on a different type of electric circuit, the reconnection should be made by qualified service personnel.

## **Building Requirements**

It is the responsibility of the building owner to ensure the building structure is adequate for the machine installation.

Electrical - please see machine label for electric power requirements. A dedicated power line and circuit breaker using machine suitable conductor wire connections and ampere rating is recommended.

## **Installation Requirements**

This installation equipment requires a local electrical circuit at the machine installation site. Your electrician may need to run a temporary service line before the installers arrive. Installer waiting time will be billed at the going rate.

A forklift and operator should be available to unload the machine from the truck and deliver the components to the installation site as required by the installers. Additional forklift time may be required during machine setup.

Installers require a floor plan of the area with the installation location for each machine model clearly marked.

A sign-off sheet has been provided for the Store Manager to indicate approval of the placement of the installed machine.

A electrician must be scheduled to connect electrical service to all machines upon completion of installation. The installation crew will then test run the machine and do a final check.

# FEATURES & SPECIFICATIONS

## Features

- **Foot cable control** – allows for operation away from the control panel
- **Mechanical counter** - measures in feet and inches using a Trumeasure measuring system
- **Simple controls** – simple to operate directional switches and cutter button
- **Pinch roller** – pulls material through the machine without damage
- **Circular cutter** – provides a clean, straight cut and automatically sharpens the blade
- **Inching wheel** – allows for precise alignment
- **Casters** – “enclosed” casters allow the machine to be used with multiple carousels when mounted on a floor track
- **Enclosed motors** – totally enclosed motors keep carpet fibers out
- **Safety controls** – security keypad prevents unauthorized use, emergency stop button

## Size

Height 3' 2"

Width 15' 10" (12' capacity)

17' 10" (15' capacity)

Depth 2' 8"

-

## Standard motors

1 @ 0.75HP, 3PH, 208/460V, 50/60Hz

1 @ 0.50HP, 3PH, 208/460V, 50/60Hz

## Electrical Requirements

208 V , Three Phase, 15 Amp

## Machine Capacities:

Material Speed - 55 ft/min

Max Cutter Speed - 150 ft/min

## 12' machine:

Max Roll Diameter - 20"/508mm

Max Roll Width - 160"/3759mm

Max Roll Weight - 500 lbs/227kg

## 15' machine:

Max Roll Diameter - 20"/508mm

Max Roll Width - 184"/4672mm

Max Roll Weight - 500 lbs/227kg



# ABOUT RACK n ROLL

The Rack N Roll machine consists of a flip up table that guides the material into the pinch roller which pushes the material across the inspection table and into the roll-up cradle where the material is rolled and wrapped or taped.

The Rack N Roll is operated from the control panel, which includes the security keypad, directional control, foot & inch counter, inching wheel, hand control button and cutter control switch.

The Rack N Roll's measuring system is made extremely accurate with the use of a Trumeasure 3900 measuring system. It consists of a large diameter, knurled measuring wheel located in a cutout of the inspection table below the hold down arm. The measuring wheel is connected to a foot and inch counter.

The cutter assembly on the Rack N Roll consists of a 5 ½" circular blade positioned within a cutter assembly inside the cutting track. The Rack N Roll also has a cutter bar that not only covers the blade while making a cut but also holds the material tight. The cutter assembly is chain driven by a dedicated cutter motor.

A foot cable control wire is provided to operate the machine "hands free" while inspecting, wrapping, unwrapping, or tending the roll.

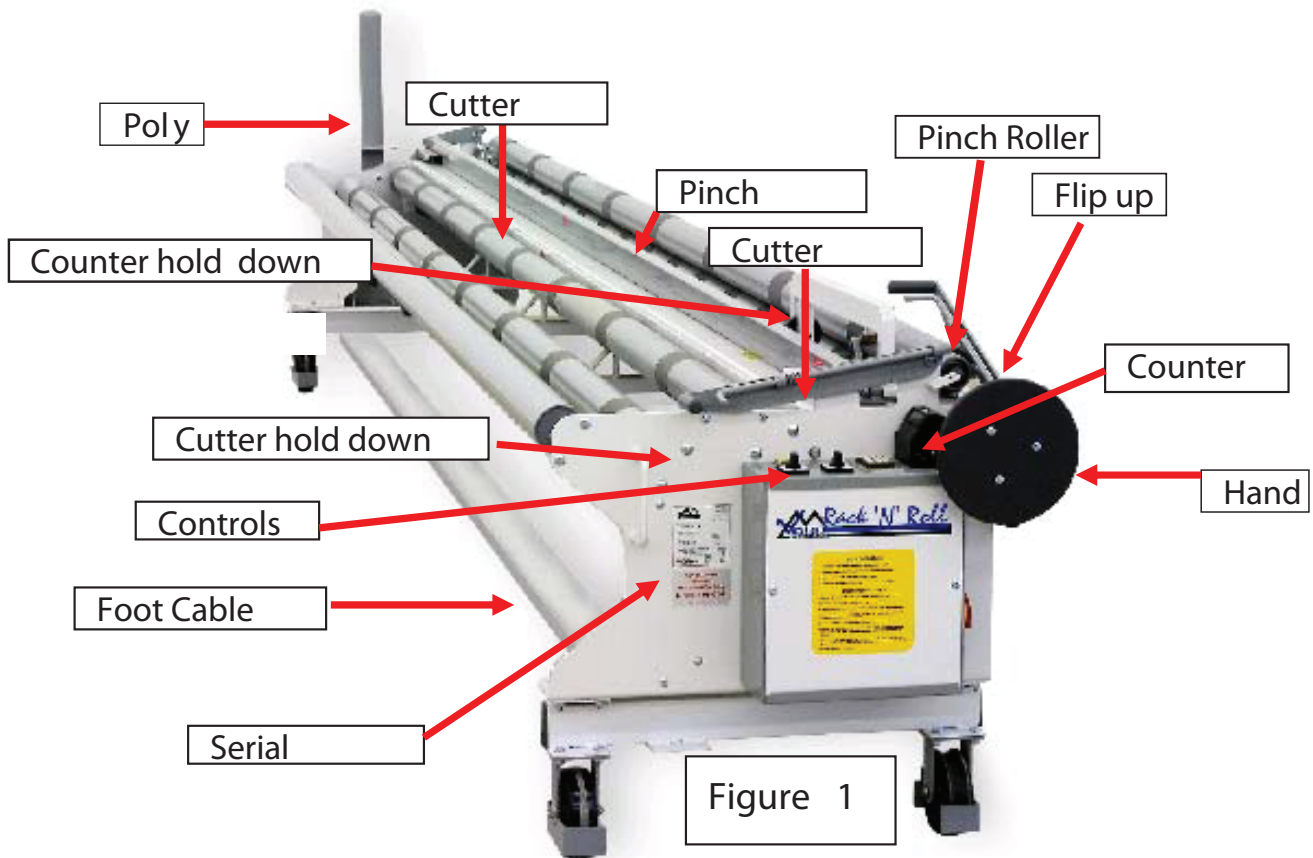

# OPERATING INSTRUCTIONS

## Operating the R10R

### 1. Positioning the roll to be cut on the R10R

Select and position the roll of material to be cut so the bottom of the roll is level with the top of the cutting machine. Remove the Velcro straps from the roll at this time.

### 2. Lining up the machine with the carpet or vinyl

Roll the machine into position so the edge of the roll is halfway between the end of the machine and the measuring wheel.

### 3. Loading the material onto the machine

- a. Raise the flip up table. This is done by raising the handle then pulling the flap toward you and locking it in position.
- b. Lower the pinch roller by pulling up on the safety latch and lowering the pinch roller. Note: The machine should always be stored with pinch roller in the down position.
- c. Flick the leading edge of the carpet onto the flip up table.
- d. Lower the roll of carpet till the leading edge is against the pinch rollers. (Be sure to lower far enough to have some slack in the carpet)
- e. Turn roller directional switch to forward.
- f. Enter the user code into the security keypad.
- g. Raise the cutter hold down bar by squeezing the safety latch, and gently lower the cutter hold down bar. Note machine should always be stored with the cutter hold bar in the down position.
- h. Engage the machine either by pressing on the inch button or stepping on the foot cable.
- i. Lower the roll of carpet until the top of the roll is level with the top the flip up table. (In cases of a heavy or oblong roll you may have to drop the flip up table at this point and lower the carpet until the top of the roll is level with the center of the pinch rollers.)

# OPERATING INSTRUCTIONS

## 4. Positioning the material to be cut on the machine

Press the inch button. Advance the material, stopping before the cutting track. Use the inching wheel to line up the edge of the material to the center of the cutting track.

Note: If the material is off square you will need to line the shorter side up with the cutting track.

## 5. Measuring the material to be cut

- a. Ensure that the backing side of the carpet is down. **Note:** difficult materials may not measure accurately (indoor/outdoor carpet, artificial turf).
- b. Reset the counter to zero by flipping the reset lever.
- c. Ensure that the roller directional switch is in the forward position. Move to the front of the machine.
- d. Stepping on the foot cable will engage the rollers and forward the material toward the operator.
- e. Once the material has been advanced approximately 18", release the foot cable to stop the machine. Form the material into a roll in the roll up cradle, starting at one end and working towards the opposite end.
- f. Operator positioning for the rolling process provides a clear view of the counter and access to the roll adjuster controls.
- g. Using the inching wheel align the material to the exact cutting position.
- h. Once the desired length is indicated on the counter, proceed to the cut operation.

## 6. Cutting the material

- a. Prior to engaging the cutter, ensure the material is tight across the cutting track and table.
- b. Lower the cutter hold down bar by squeezing the safety latch, and gently lower the cutter hold down bar. Note machine should always be stored with the cutter hold bar in the down position.
- c. Engage the cutter by rotating cutter control switch. Release the cutter control switch to stop the cutter. This machine is designed with a bi-directional cutter, and specific cutting direction is not necessary. Always park the cutter under either one of the garages when not in use.

## 7. Wrapping the material

- a. Prior to wrapping material, raise the pinch roller.
- b. Insert the stretch wrap inside the roll flap and engage the rollers with the foot cable, wrapping the material as it turns. This same process can be repeated several times until the roll is adequately wrapped.
- c. When using poly wrap, pull the wrap to the end of the material and use a utility knife to cut off the other end. Unroll the poly wrap and insert one end in the roll flap. Engage the rollers and wrap the material as it turns.

# **OPERATING INSTRUCTIONS**

## 8. Finishing the job

- a. The wrapped material can now be loaded onto a carpet cart.
- b. Pull the carpet off the cutting machine and roll the loose end back onto the roll of carpet.
- c. Move the cutting machine away from the roll.
- d. Secure the roll with minimum of (3) Velcro straps.

## 9. Sharpening the blade

The cutting system is equipped with a self-sharpening mechanism. It is not necessary to remove the blade for sharpening.

To sharpen the blade, run the cutter to the far end of the machine and keep on running it for an additional 7-10 seconds. During this time you will hear a grinding/grating noise.

It is recommended that the blade be sharpened from 7 to 10 seconds after every 50 cuts

# OPERATING INSTRUCTIONS

## 212e Keypad



This machine has the built-in safety feature of a security keypad to prevent unauthorized operation of this machine. This keypad has been supplied with factory settings, including the password required to activate the controls.

Password Customization - the keypad requires a moment to register each step:

### PRESS

1. 99#
2. Current code\*
3. 30#
4. 1#
5. NEW 4 DIGIT CODE \*
6. NEW 4 DIGIT CODE \*
7. \*

### KEY PAD LIGHT

- steady red
- flashing yellow
- flashing yellow
- flashing yellow
- fast flashing yellow
- flashing yellow
- steady red

Once this sequence is completed, your new password is programmed and should be used to activate the controls.

### **PLEASE NOTE:**

The security password protects against unauthorized operation of the equipment. Factory default setting allows the machine to be idle for 30 seconds before the password expires. After 30 seconds of machine idle time, the keypad will time out and operator's password must be reentered to activate the controls.

Note: To reset your keypad to factory settings, please refer to the instructions located on next page.

# OPERATING INSTRUCTIONS

## 212e Keypad

### Restore Factory Defaults:

1. Turn the red power switch off.
2. Press and hold the jog push-button.
3. While holding the jog push-button turn the red power switch on.
4. Continue to press and hold the jog push-button until you hear a couple of beeps.
5. Release the jog push-button.
6. The yellow light should be flashing.

Follow the steps below to reset the keypad - the keypad requires a moment to register each step:

<b>Press Keys</b> .....	<b>Keypad Lights</b>
46# .....	flashing yellow
00000#.....	flashing yellow
00000#.....	flashing yellow
* .....	fast flashing yellow
* .....	flashing yellow
30# .....	flashing yellow
1#.....	flashing yellow
ENTER CODE * .....	fast flashing yellow
ENTER CODE * .....	flashing yellow
* .....	steady red

### Changing Code and Timer:

<b>Press Keys</b> .....	<b>Keypad Lights</b>
99# .....	steady red
2. Current code* .....	flashing yellow
3. 30# .....	flashing yellow
4. 1# .....	flashing yellow
5. NEW CODE * .....	fast flashing yellow
6. NEW CODE * .....	flashing yellow
7. * .....	steady red



# OPERATING INSTRUCTIONS

## Resetting IEI (stainless steel plate) keypad

In use from July 2000 - July 2006



To restore key pad to factory default settings

1. Remove keypad from machine
2. Press dip (black or white) switch button on back of keypad [top] (behind key #2) Flashing yellow light should come on [button is right beside the row of 8 resistors]

<b>Press .....</b>	<b>Keypad light</b>
1. 46#.....	flashing yellow
2. 00000# .....	flashing yellow
3. 00000# .....	flashing yellow
4. * .....	fast flashing yellow
5. * .....	flashing yellow
6. 30# (= 30 sec max 90).....	flashing yellow
7. 1# .....	flashing yellow
8. CODE * .....	fast flashing yellow
9. CODE * .....	flashing yellow
10. * .....	steady red

# OPERATING INSTRUCTIONS

## Visonic Keypad

In use until July 2000



### Changing Code:

**Press Keys** ..... **Keypad Lights**  
 Enter your current code ..... steady green flashing  
 101 # ..... fast flashing green  
 NEW CODE # ..... steady green for 2 seconds then slow steady flashing  
 NEW CODE # ..... steady green for 2 seconds then slow steady flashing  
 Wait 5 seconds, then press # ..... steady red light

### Setting Timer:

**Press Keys** ..... **Keypad Lights**  
 Enter your current code ..... steady green flashing  
 2 ..... rapid flashing green light  
 98 ..... set timer between 01 - 98 seconds  
 # ..... steady green for 2 seconds, then rapid flashing  
 # ..... steady red light

### Setting Trip Code:

**Press Keys** ..... **Keypad Lights**  
 Enter your current code ..... steady green flashing  
 3 ..... rapid flashing green light  
 3 ..... trip code  
 # ..... steady green for 2 seconds, then rapid flashing  
 # ..... steady red light

# TROUBLESHOOTING

1. Machine will not stay on track
  - a. Check the track for debris.
  - b. Ensure the track is in good condition. It should be straight and level with no gaps between sections.
  - c. The wheels may be out of alignment. To adjust the wheels, loosen the 4 bolts that hold the caster wheel assembly to the frame of the machine. Do this to both of the grooved caster wheels. Push the machine up and down the track a few times and then re-tighten the bolts. If the problem persists, loosen the 4 bolts on each of the non-grooved caster wheels and follow the same procedure. Stretch a string along the outside of the wheels to ensure they are in line. Set-up tip: to ensure smooth operation, adjust the casters with a slight toe-in attitude.
  - d. The machine may jump the track if pushed too fast.
  - e. If the machine has jumped the track inspect the festoon cord for damage.
  
2. Unit is not measuring correctly
  - a) To evaluate the counter calibration, run a tape measure through the counter. It should be accurate to within ½" on 15'.
  - b) Follow these steps to conduct the test.
    1. Place the tape measure between the counter weight and the counting wheel.
    2. Pull tape measure and hook it to the cutting bar edge.
    3. Reset counter to "0".
    4. Pull tape measure guiding it carefully to keep on the counting wheel.
    5. Pull until the 15' mark is at the cutting bar edge.
    6. Read counter display it should be within ½ inch.
  - c) If this test proves counter to be accurate, then you can assume the counter is fine and the problem is with the procedure or with the type of flooring that is being measured.
  - d) To further verify or check calibration on a Rack N Roll Carpet Cutter, a test strip is required. To make your own test strip, take a medium weight carpet and roll it on the floor and mark it at 15' on both edges.
  - e) Feed the test strip into the machine until the edge is in the center of the cutting track. Reset the counter to "0". Roll the material through the machine until the mark on the test strip is in the center of the cutting track. At this time, take notice of the counter display – it should be within ½ inch of the actual length of the test strip. NOTE: BACK SIDE OF CARPET MUST ALWAYS BE DOWN.
  - f) If the counter display is not accurate, redo the test at least two or three times and note the counter reading for each test. Various kinds of carpet will measure slightly different. TURF CARPET DUE TO THE STRETCHING CAN NOT BE MEASURED ACCURATELY. RUBBER OR FOAM BACK CARPETS WILL BE SHORT.
  - g) Look over the mechanical aspects of the counter. Inspect the knurled measuring wheel for wear and damage. Check the measuring wheel to ensure it is securely fastened to the counter shaft and that the counter shaft is securely fastened to the counter.
  - h) Spin counter wheel to ensure that it spins freely in either direction.
  - i) Ensure the counter hold down wheel is centered above the measuring wheel.

# TROUBLESHOOTING

- j) Check the counter to verify that there are not any broken pieces on it, and that the housing is in good shape and the spring-loaded reset is in position.
- k) If you are sure the counter is inaccurate, call the factory 1-800-210-0141.

## 3. No power to the machine

- a. Check to see if the power indicator (red light) on the keypad is on.
- b. Check to make sure the yellow/red switch is turned on.
- c. Check to ensure the breaker is on. Locate the breaker and turn it all the way off and then on.
- d. Locate the shut off switch located on the drop down box at the end of the yellow cord and check the fuses.
- e. Check for proper incoming voltage between phases at the drop down box.
- f. Check yellow festoon cord for cuts or breaks.
- g. Check for proper incoming voltage at the shut off switch.
- h. If the red light still isn't lit on the keypad, then obtain an electrical tester and check for 24 volts between + - at the keypad. If the voltage is present, the keypad may just need to be reset.

## 4. Power to the machine, no red light on the keypad

- a. Check the incoming transformer wires (red, black) for proper incoming voltage.
- b. Check the transformer yellow and blue wires should have 24 volts AC (Terminals + - on IEI).
- c. If the transformer has proper incoming voltage but no 24 volts then replace the transformer.

## 5. Power to the machine, red light lit on the keypad and the key pad activates when the code is entered but unit just buzzes when roller button is activated.

(This indicates machine may have lost one leg of the 3 phase power)

- a. Raise cutter hold down bar Rollers will not run if the cutter hold down bar is down.
- b. Reset breaker at building electrical power supply box.
- c. Inspect yellow power cord for damage.
- d. Check all 3 phases for proper incoming voltage at all points at the master power shut off switch.

## 6. Power to IEI KEYPAD (indicated by red light) but the keypad will not activate when the code is entered

- a. Green light does not turn on when code is entered.
- b. Note the yellow light -it should flash at each key stroke.
- c. Remove keypad and wiggle the circuit board and then try again.
- d. Reset keypad.
- e. Replace keypad.

# TROUBLESHOOTING

7. Key pad accepts the code but the rollers will not operate
  - a. Raise the cutter hold down bar (rollers will not run with it in the down position).
  - b. Ensure roller switch is turned to forward.
  - c. Ensure foot cable and inch button are operating properly. You should hear a click in the electrical box when you press the inch button or step on the foot cable.
  - d. Check foot cable tension-it should click and unclick as you press and release it. (Sometimes the brackets get bent and this tightens the foot cable to the point where it will not release.)
  - e. Listen for the click at the contactor each time the inch button is pressed.
  - f. Check for any loose wiring at the contactor or in the electrical box.
  - g. Check for 24 VAC at terminals A1-A2 at the roller contactor while engaging the inch button.
  - h. Replace the contactor if 24 volts are present.  
If not, trace wiring and probe to find where power went missing
  - i. Engage contactor manually - the machine should run.

## NOTE

The rollers will not operate if the cutter hold down bar is down. As well, the cutter will not run if the cutter hold down bar is raised.

8. Keypad accepts the code but cutter will not run
  - a. Lower the cutter hold down bar (Cutter will not run if in the raised position)
  - b. Ensure cutter switch is turned to forward.
  - c. Ensure inch button is operating properly. You should hear a click in the electrical box when you press the inch button.
  - d. Check the foot cable tension. It should click when it is engaged and also when released. (If too tight, it will cause the interlocking contactor to lock out the cutter contactor)
  - e. Listen for a click at the contactor each time the cutter inch button is pressed.
  - f. Check for any loose wiring at the contactor or in the electrical box.
  - g. Check for 24 VAC at terminals A1-A2 at the cutter contactor while engaging the inch button.
  - h. Replace the contactor if 24 volts are present.
  - i. If not, trace wiring and probe to find where power went missing
  - j. Engage contactor -manually the cutter should run.
9. Rollers run but the cutter will not engage
  - a. To activate the cutter the cutter hold down bar must be lowered and the cutter directional switch activated.
  - b. Lower the cutter hold down bar as the cutter will not run with it in the raised position.
  - c. Take note if the cutter contactor clicks as the bar is lowered.
  - d. If cutter contactor buzzes this indicates that the roller contactor is still engaged. This could be caused by a tight foot cable or a stuck contactor.

# TROUBLESHOOTING

- e. If contactor doesn't click or buzz check the following.
    - (i) Check cutter safety switch for proper operation.
    - (ii) On the cutter safety switch be sure the magnets line up and that the ice cube relay is plugged in fully and is operating properly.
    - (iii) Check for any loose wires.
  - f. Check motor connections on the contactor.
  - g. Engage the cutter contactor manually if this fails to run the unit. Replace the contactor. This is a double inter- locking contactor. (Both roller and cutter run off this contactor)
10. Cutter runs with the cutter hold down in the raised position / rollers will not run at all/ roller inch button only buzzes
- a. Check cutter hold down bar safety switch adjustment.
  - b. Adjust switch activator lever to contact the switch button.
11. Cutter runs but will not cut material
- If the motor is running and the cutter gets stuck in the cutting process, check the following:
- a. Run blade to far end of machine and sharpen it for 35 seconds. Try to cut again.
  - b. If step (a) is not successful run cutter to far end (disconnect power) and lift the covers to check if the blade is engaging the sharpening discs. Adjust as needed.
  - c. Check the blade for wear; replace the blade, if needed.
  - d. If step (b) isn't successful and cutter gets stuck in the cutting process, tighten the cutter clutch springs.
  - e. If the cutter still will not cut, check the belt tension on the motor. If the belt is loose, tighten it by loosening the 4 motor mounting nuts. Tighten belt tension by turning the tension adjuster nut against motor base plate, sliding the motor.
12. Foot cable not activating the machine
- a. Enter keypad code and ensure machine is on.
  - b. Raise the cutter hold down bar. (It must be in the raised position to run the rollers.)
  - c. Ensure the roller switch is turned on.
  - d. Check the cable tension. If very loose, tighten. The cable is fastened with the eyebolt at the far end of the machine. Remove slack by tightening eyebolt.
  - e. Check the foot switch activating lever.
13. Material will not feed through the machine
- a. Make sure the pinch roller drops down fully and evenly onto the drive roller.
  - b. Check the gripper tape on the drive roller for excessive wear.
  - c. Check that the top of the carpet roll is not higher than the drive roller.
  - d. Replace worn out gripper tape if needed, add an additional gripper tape between the existing ones on the bottom pinch drive roller.
  - e. Ensure that center roller support is installed on the XL machines.

# TROUBLESHOOTING

Problem: Cutting blade is dull

Solution: 1. Sharpen blade

2. Adjust the cutting blade sharpening disk

## Adjusting the Cutter Sharpening Disk

1. Run the cutter to the far end of the machine.
2. Turn off the power switch (red knob on the side of the electrical box)
3. Raise rear blade cover to expose blade.
4. Check that the cutter blade is engaging properly with the flap disc. (E) It should be putting pressure on one side of the blade causing it to deflect.
5. Ensure that the cutter blade is backed up far enough to engage the flap disc. They should overlap by  $\frac{3}{4}$ ". If not, then the cutter clutch needs to be tightened. (see cutter clutch tightening instructions). See page 21
6. If the cutter blade is far enough back, but the blade is not pressing against the flap disc, (E) then the flap disc needs to be adjusted and/or replaced to make contact with the cutter blade.
7. To increase flap disc pressure, loosen the 2 retaining set screws and slide the disc (E) closer to the blade until it puts pressure on the blade. Retighten the set screws.
8. Check the flap disc (E) for wear. If it is worn or gummed up. Replace it with part # 300-0047.
9. To remove the flap disc, remove the flap disc mounting bolt (D), spring and hub.
10. To install flap disc, align hole in the flap disc with guide pin on the hub, insert bolt with spring and tighten.
11. Close the rear blade cover.
12. Test if the sharpener works by running the blade to the front of the machine and then running it to the back end. Once it reaches the far end keep the switch engaged for an additional 15 seconds. During this time you should hear a grinding noise as the blade is being sharpened.
13. Lift rear blade cover and check the sharpness of the blade. If satisfactory, close the rear blade cover. If not, sharpen for another 30 seconds
14. If this fails replace the blade.

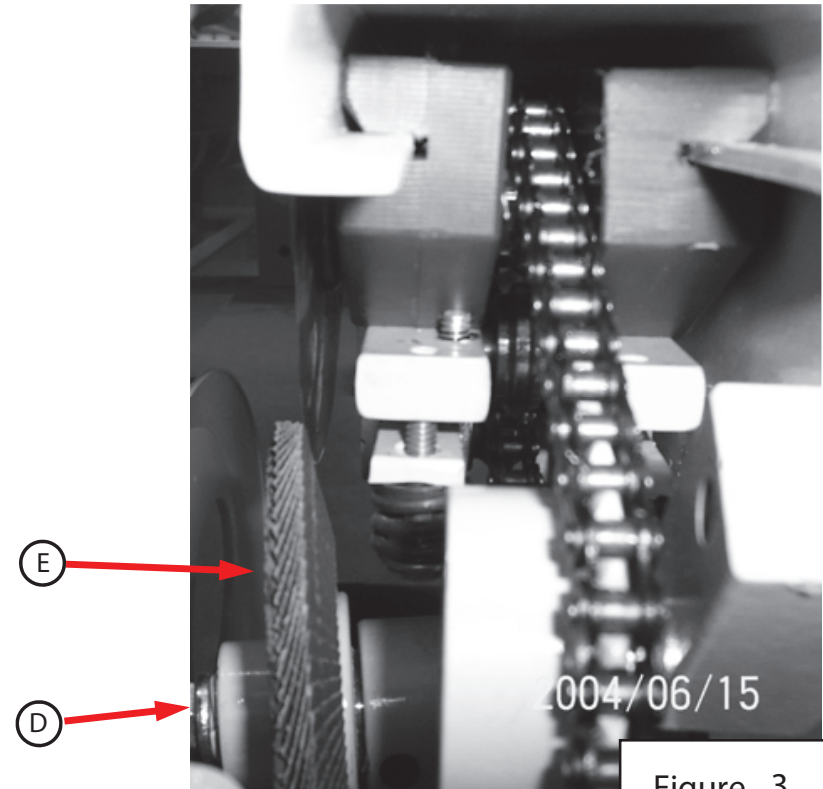

Figure 3

# TROUBLESHOOTING

Problem: Cutting Blade Is Dull – Requires Replacement

Solution: Cutting Blade Replacement

1. Run the cutter to the far end of the machine just before the Flap Disc.
2. Turn off the power switch (Red Knob on the side of the electrical box).
3. Raise or Remove the Rear Blade Cover to expose the blade.
4. Remove the Blade Mounting Bolt and Blade Cap.
5. Remove the Blade and Install the New Blade.
6. Reinstall the Blade Cap, Blade Mounting Bolt and Tighten.
7. Adjust the Flap Disc by loosening the 2 Set Screws (A) and sliding the disc in or out until it makes firm contact with the blade.
8. Tighten Both of the Set Screws.
9. Close the Blade Cover.
10. Turn on the Power Switch back on.
11. Run the Cutter Back and Forth a couple of times and check that the Blade overlaps the Flap Disc by  $\frac{3}{4}$ " (B).

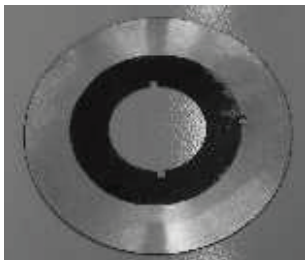

Cutting Blade-  
Part# 103-0002V

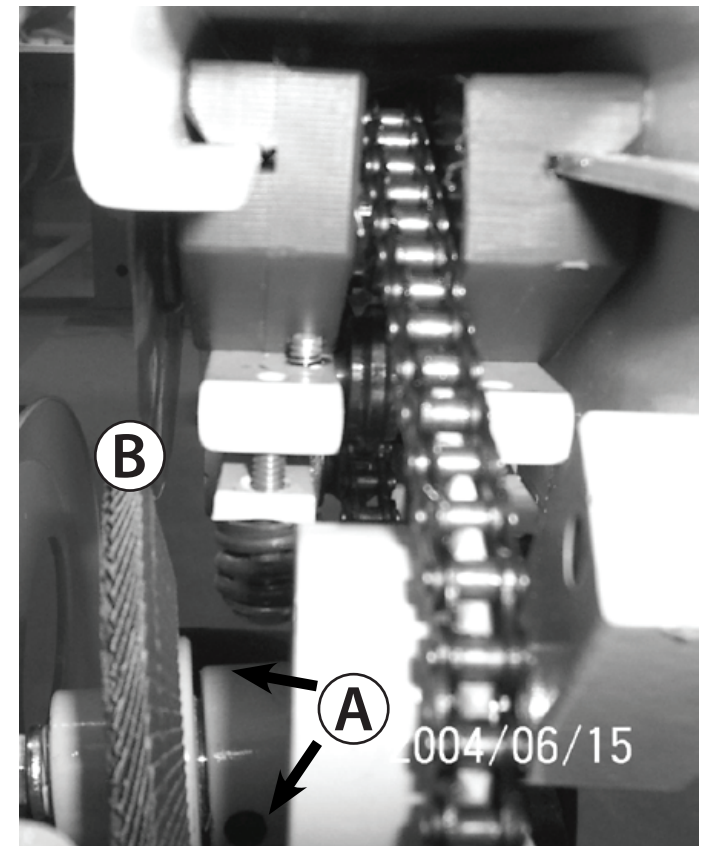
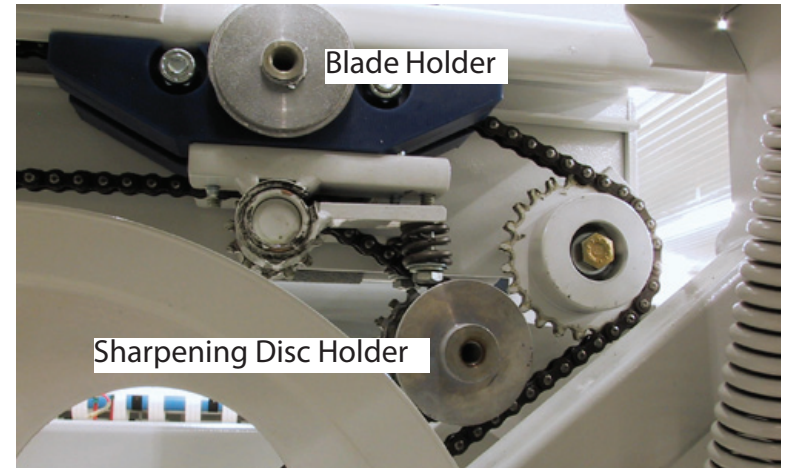



# TROUBLESHOOTING

Problem: Cutter stalls in the middle of a cut

Solution: Check cutter drive belt tension

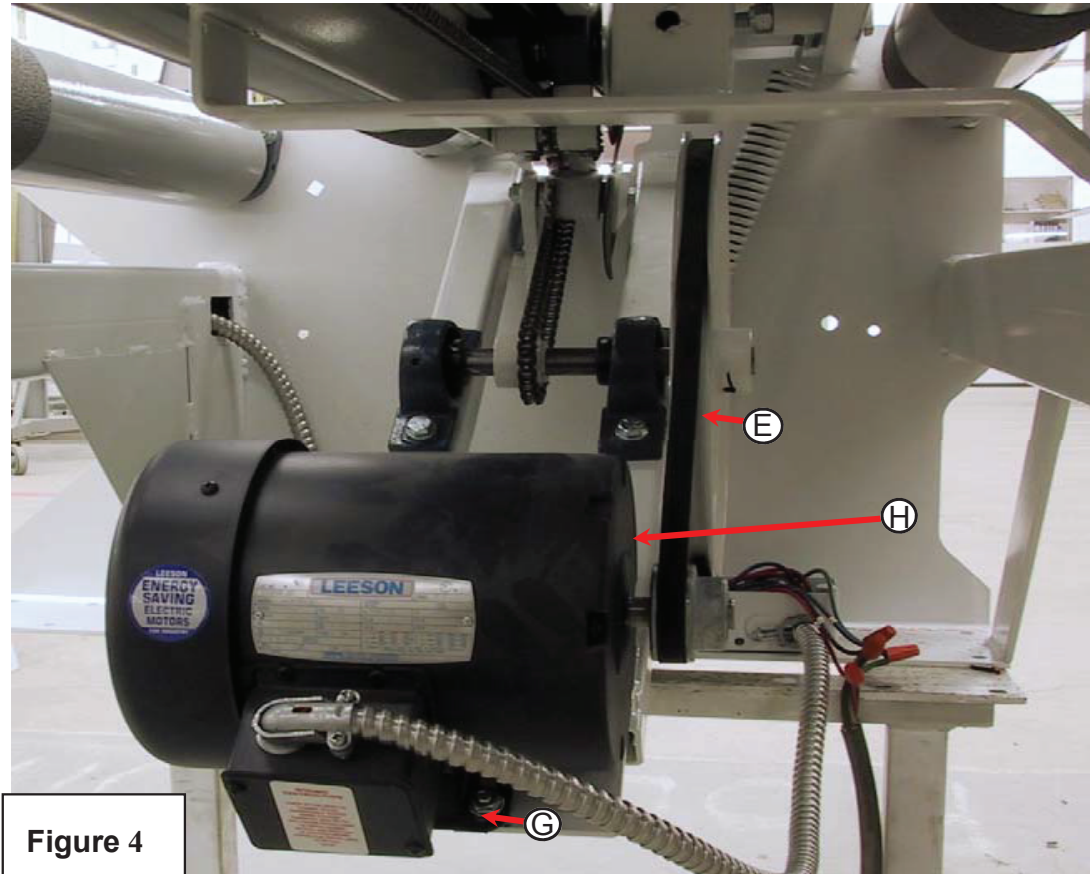

Figure 4

## Adjusting Cutter Motor Drive belt (E)

Loosen the motor mounting bolts (4) (G)

Turn motor slider nut (H) clockwise to tighten belt until (with reasonable effort) the belt only deflects 3/8".

Tighten motor mounting bolts (4) (G)

# TROUBLESHOOTING

Problem: Cutter stalls in the middle of a cut or doesn't travel far enough to the back to sharpen the blades or far enough to the front to enter the hide in the garage completely

Solution: 1. sharpen blade

2. adjust cutter clutch tension

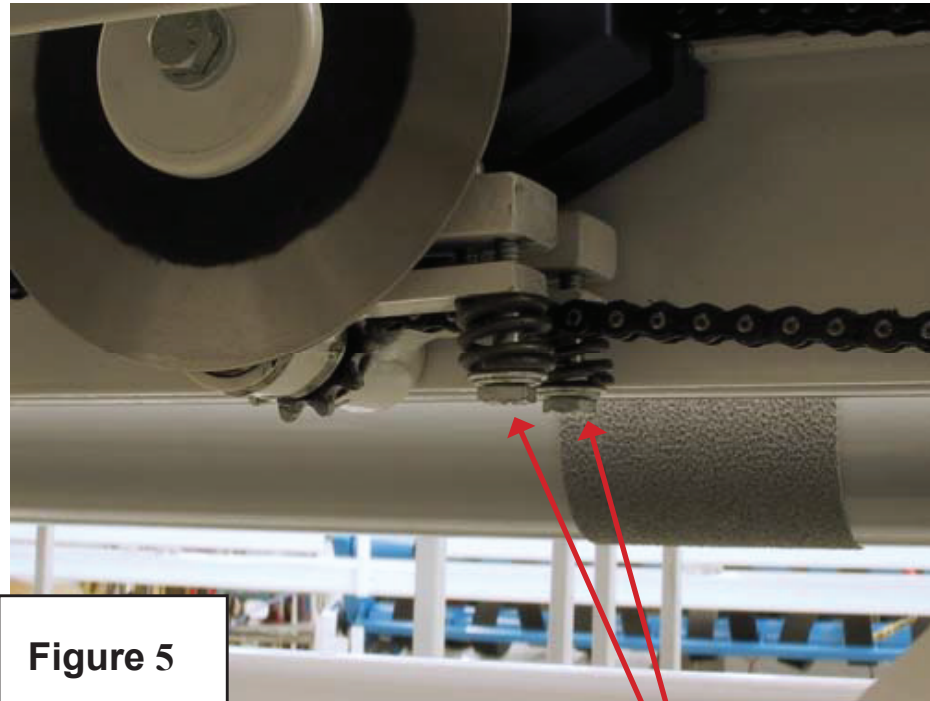

**Figure 5**

Adjusting Cutter Clutch Tension

1. Park the cutter in the center of the machine.
2. Tighten the 2 cutter clutch tensioning springs by turning the spring bolts. Tighten each of the bolts 1/4 turn clockwise. Run the cutter to see if the problem has been corrected. **DO NOT OVERTIGHTEN!**
3. If the problem still persists, repeat the procedure until the problem disappears.

Your clutch adjustment is correct if cutter motor stalls when the cutter is forced against the control end and still sharpens at the far end.

# TROUBLESHOOTING

Problem: Cutter chain is excessively noisy

Solution: Check cutter chain tension

Tighten as necessary

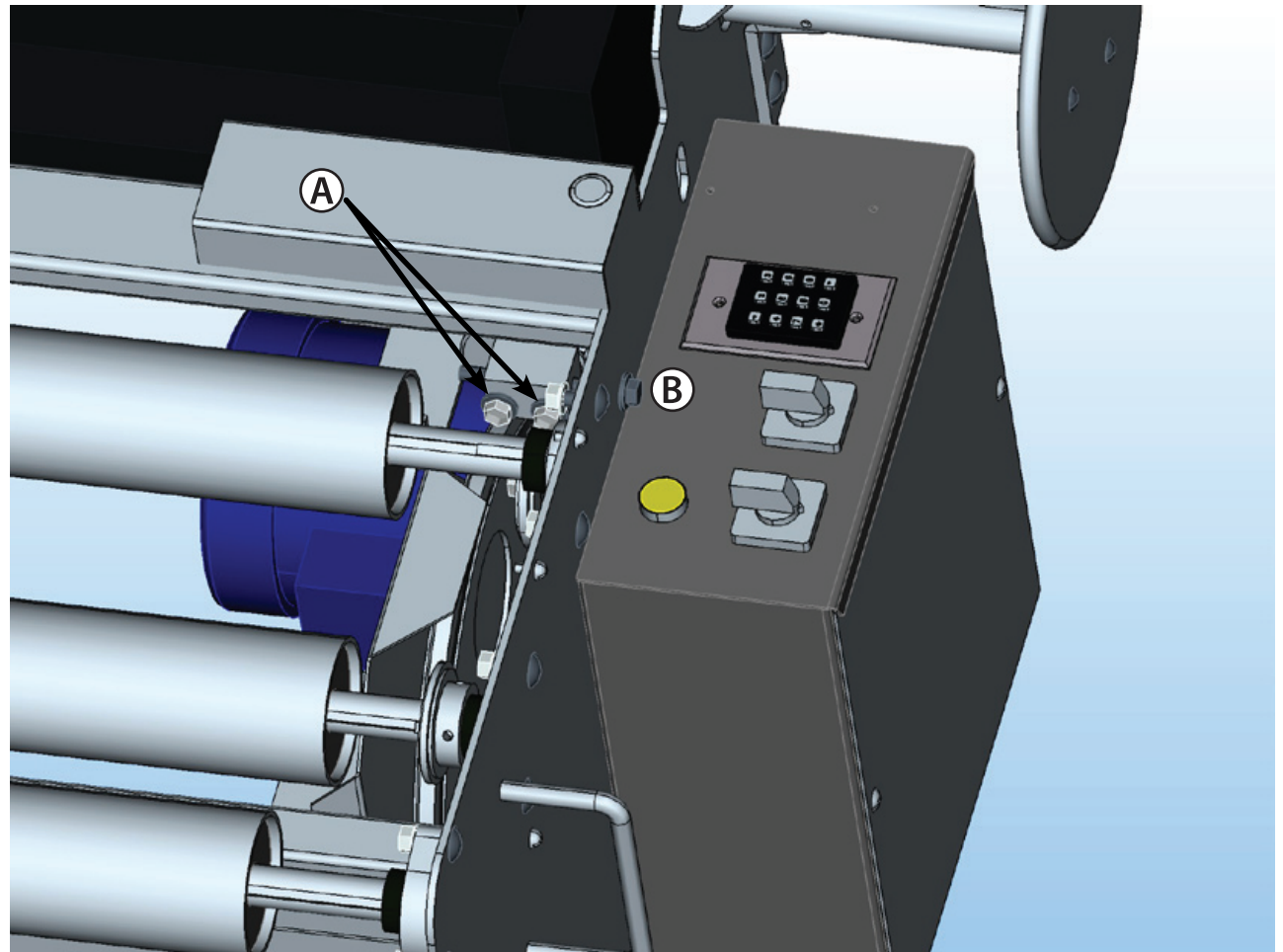

Tightening the cutter chain

Loosen the 2 front cutter idler mounting bolts (A).

Turn the front cutter idler tightener bolt (B) clockwise until chain has proper tension [chain should not rub on the cutting bar support brackets].

Tighten the front cutter idler mounting bolts.

# R5-R10 COMPONENTS MANUAL

CUTTING BAR HOLD DOWN AND  
PINCH ROLLER LATCHES  
page 45

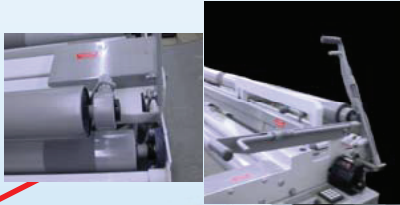

COUNTER COMPONENTS  
page 46

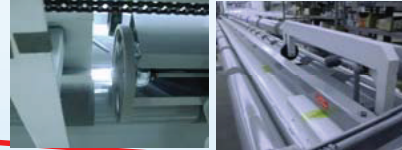

ELECTRICAL COMPONENTS  
page 29 page 30

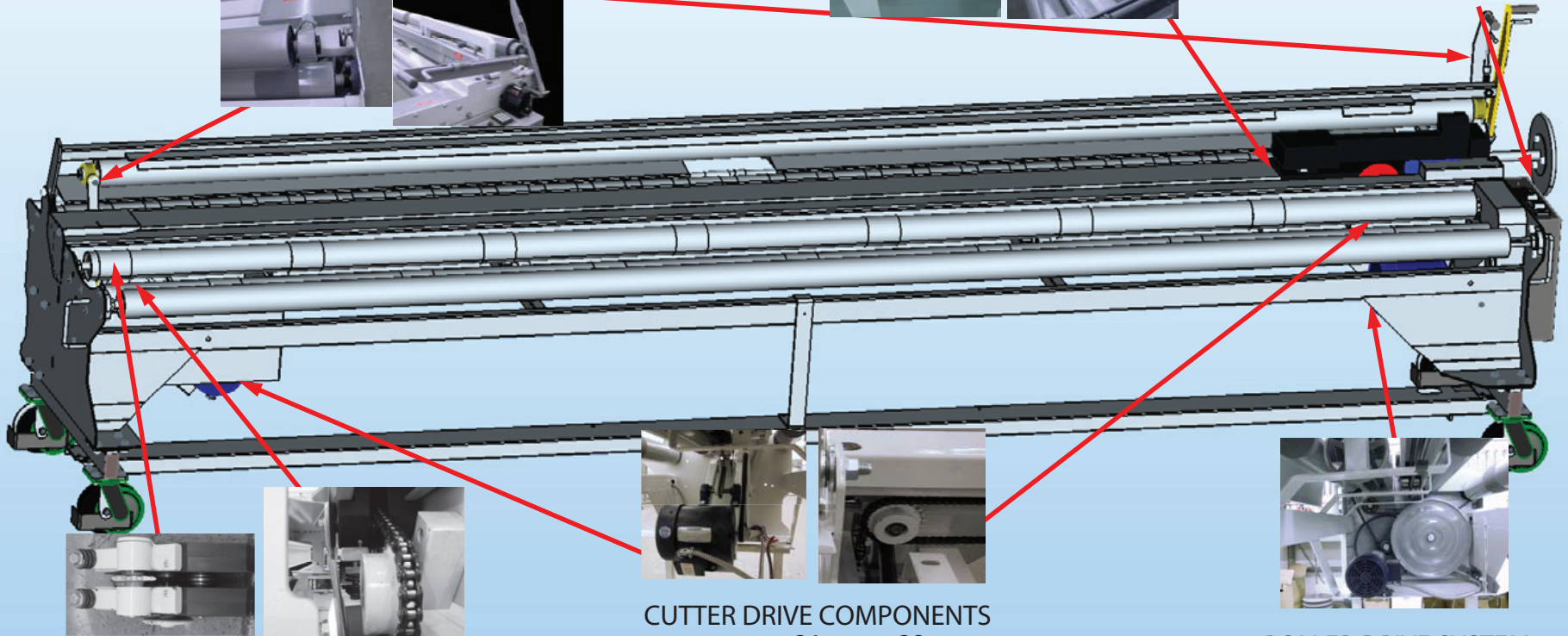

BLADE HOLDER AND SHARPENER  
page 33, page 42

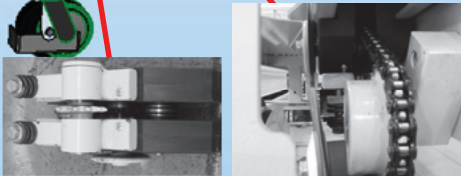

CUTTER DRIVE COMPONENTS  
page 31, page 32

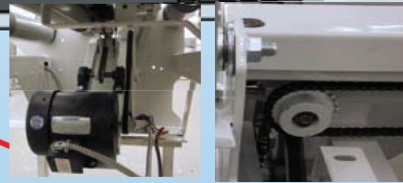

ROLLER DRIVE SYSTEM  
page 43



# ELECTRICAL COMPONENTS

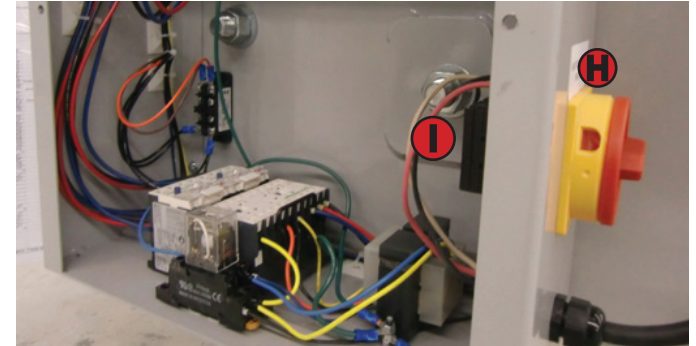
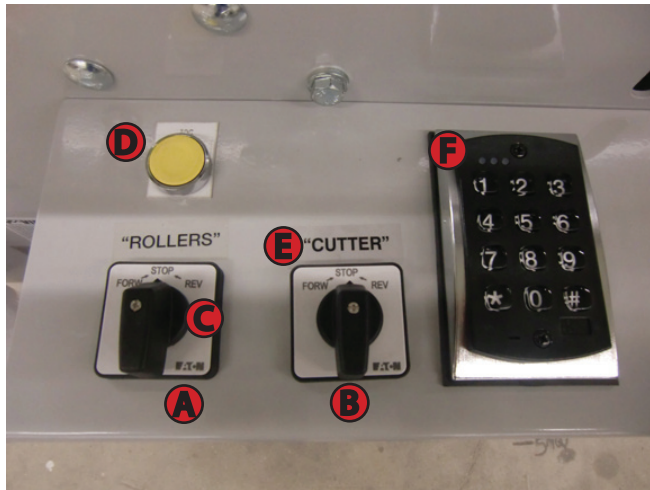

H. Master switch knob & yellow plate 410-0068  
I. Master shut off switch ..... 410-0044

Description	part number
A. Roller f/w switch 3 phase .....	410-0029
B. K/m f/r switch knob.....	410-0026
C. K/m f/r switch stem .....	410-0052
D. RnR jog button with 3 N/O contacts complete.....	410-0070
E. Cutter f/r switch 3 phase .....	410-0031
F. IEI key pad.....	410-0104

G. TruMeasure 3900 counter ..... 402-0003

J. Transformer 208-24v .....	411-0002
K. Ice cube relay 24 vac .....	409-0020
L. Interlocking f/r contactor.....	409-0039
M. Foot switch .....	410-0038
N. Electrical box.....	7-6200
O. Electrical box cover.....	7-5570
L-1. Thermal Overload.....	409-0046
L-2. Thermal Overload.....	409-0067
Complete E-box with all components.....	7-50649

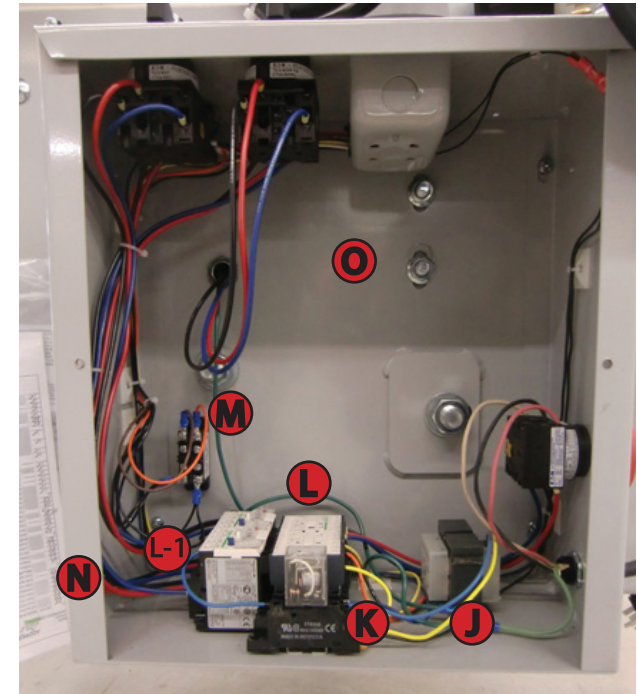

# ELECTRICAL COMPONENTS

P. Cutter safety switch sensor.....	410-0114s
Q. Cutter safety switch magnet.....	410-0114m
R. Cord mast square tube (call to confirm) .....	7-5080
S. Cord mast round tube standard (call for details).....	7-5080
T. Cord trolley.....	405-0001
U. Push/pull cord trolley .....	405-0014
V. Festoon cord (yellow) spec # of feet .....	405-0002
W. Festoon track spec # of feet.....	405-0007
note: items R - X is not shown in this diagram.	
Festoon track joiner.....	405-0012
Festoon bolted track hanger assembly .....	405-0004
Caster 6" rigid w/toe guard groove.....	104-0040
Caster 6" rigid w/toe guard.....	104-0006
RnR stretch wrap dispenser.....	7-5030
L-bracket (old style) festoon track hanger.....	7-5270

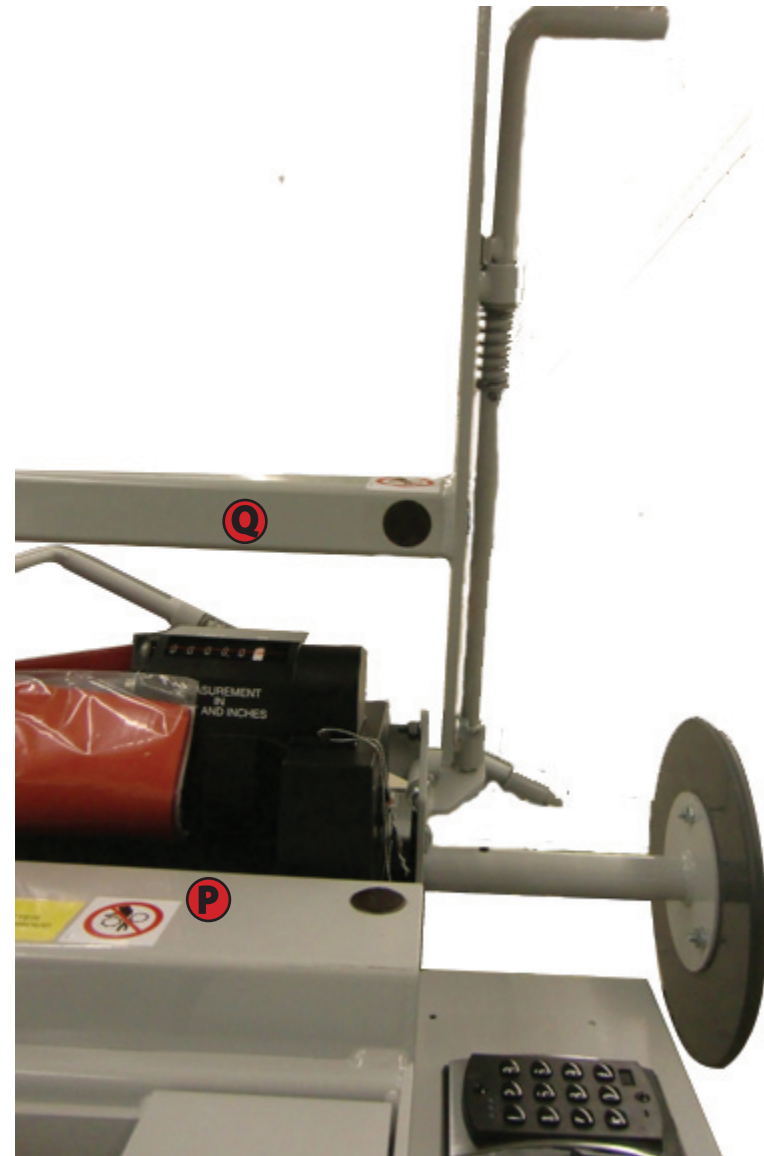

# CUTTER DRIVE COMPONENTS

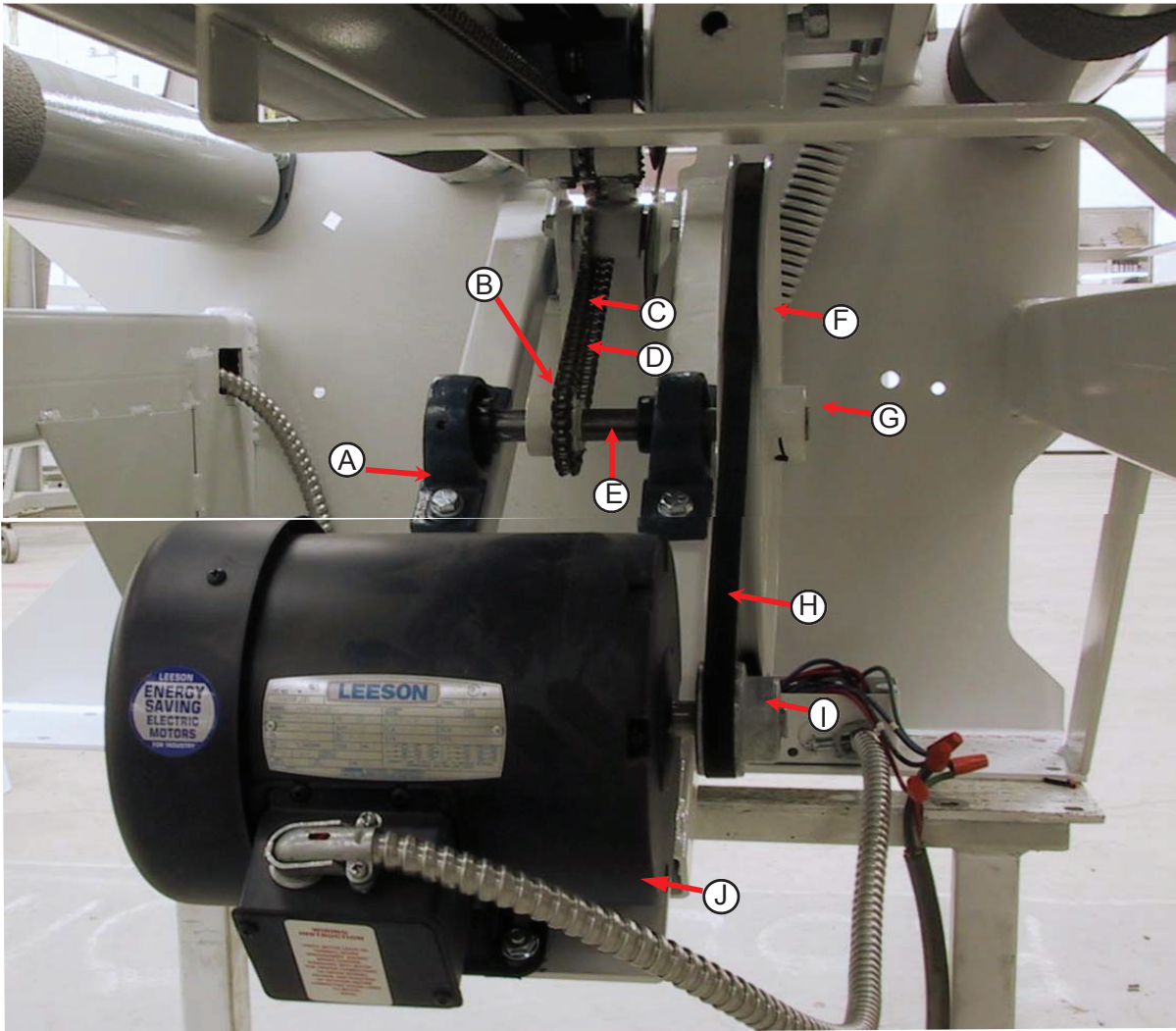

Description .....	Part number
A. 204 pillow block w bearing .....	006-0031
B. 3517 cutter drive sprocket.....	120-0013
C. #35 Cutter Chain R&R reg.....	103-0006
#35 cutter chain R&R XL.....	103-0019
D. Chain #35 connector link .....	105-0068
E. Cutter drive cross shaft .....	8-44689
E-1 3/4" x 8" cutter drive shaft w/ keystack.....	8-53325
F. 12" pulley.....	844690
G. Key 3/16" X 1 1/2" .....	8-53391
H. A43 belt .....	102-0035
I. Cutter motor drive pulley.....	115-0017
J. 3/4 HP Motor, 3 PH, 208v.....	407-0006
K. Cutter motor cover (not shown).....	7-5980

# CIRCULAR CUTTER COMPONENTS

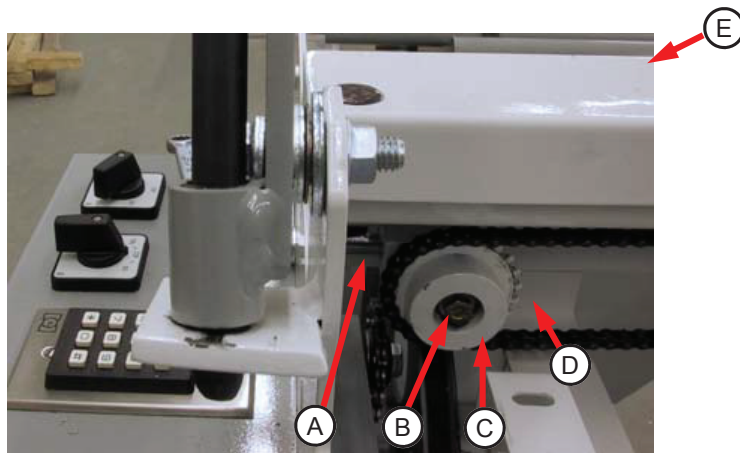

Description	Part Number
A. Tightener Bolt .....	001-0122
B. 3/8 x 1 1/2" Bolt.....	001-0207
C. End Sprocket #3523 .....	120-0067
D. Cutter Tightener Block.....	8-5330
E. Blade cover extension .....	7-6380

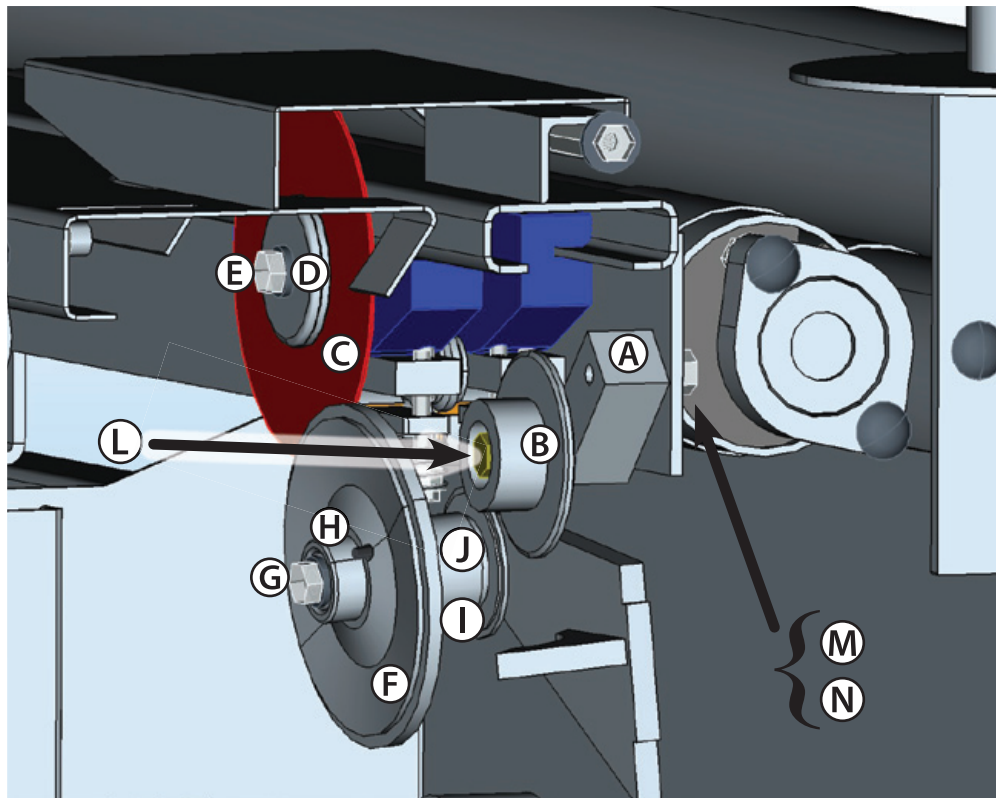

Description	Part number
A. End sprocket mounting block .....	8-44687
B. End Sprocket #3523.....	120-0067
C. Blade ...5 1/2" .....	103-002V
Blade...4 1/2" .....	103-0003
D. Blade Cap.....	8-8080
E. 3/8 x 3/4" blade bolt .....	001-0113
F. Flap disk .....	300-0047
G. Sanding disk mounting bolt.....	001-0119
H. Sanding disk hub .....	8-43420
I. Sharpener sprocket.....	8-44691
J. Set screws 5/16" x 3/8" for item H .....	002-0028
K. Chain #35 connector link (not shown).....	105-0068
L. Sharpener mounting bolt hex L9 3/8 X 1-1/2 .....	001-0207
M. Mounting block bolt hex 3/8 X 3/4 .....	001-0113
N. Mounting block washer 3/8.....	003-0060



# CUTTER COMPONENTS

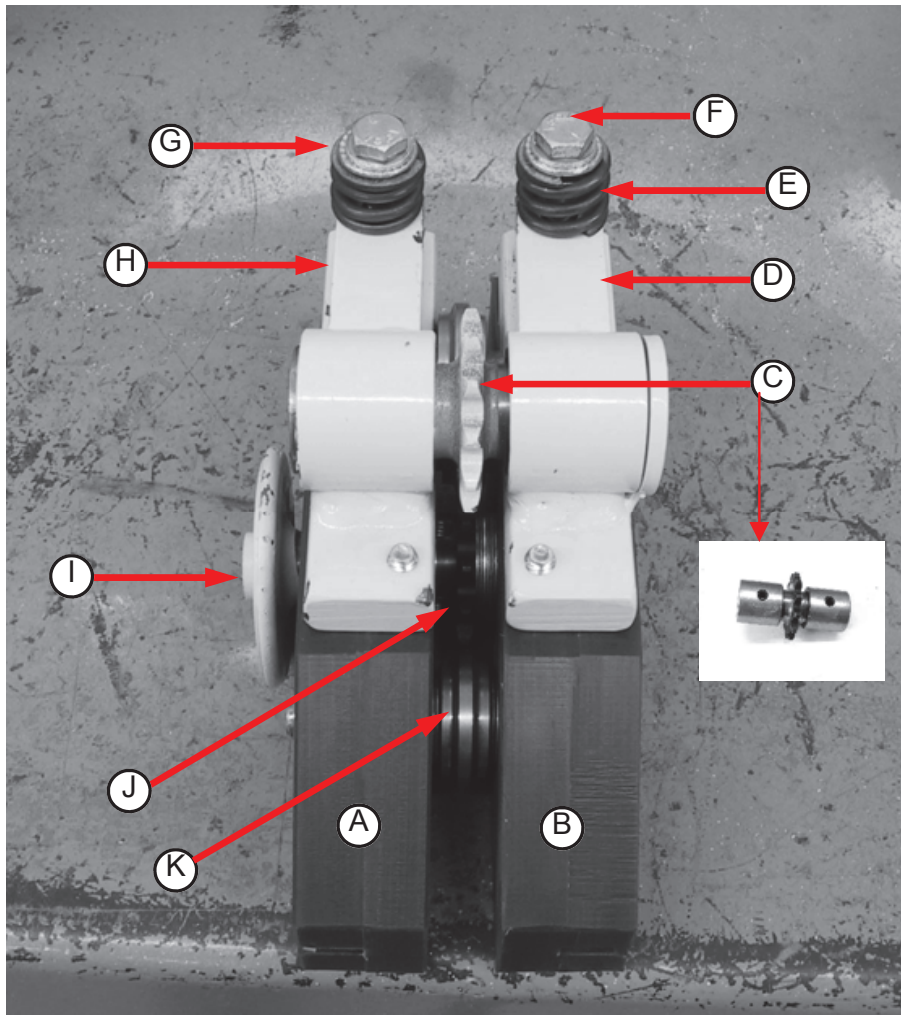

## CIRCULAR CUTTER

Description	Part number
A. LT-CCC-GUIDE-BLOCK .....	8-8030
B. RT-CCC-GUIDE-BLOCK.....	8-8020
C. Clutch shaft w/bushings and welded sprocket ....	8-8160
D. Clutch clamp w/ washer.....	8-8240
E. Clutch spring (2).....	119-0014
F. 1/4x2 Bolt (2) .....	001-0089
G. 5/16" flange nut (2) .....	004-0014
H. Clutch Clamp.....	8-8120
I. CC-BLADE-SHAFT.....	8-8050
J. Blade shaft sprocket .....	120-0005
K. Chain Idler .....	8-8100
Circular cutter complete .....	part# 8-46897

Clutch replacement kit.....part# 8-55424  
includes all items listed below

Description	Part number
C) Clutch shaft w/bushings and welded sprocket....	8-8160
D) Clutch clamp w/ washer.....	8-8240
E) Clutch spring .....	119-0014
F) 1/4x2 Bolt .....	001-0089
G) 5/16" flange nut .....	004-0014
H) Clutch clamp.....	8-8120

Clayton Homes uses the following.

Complete crossbow j5 cutter & block.....	#8-44271
Double blade holder crossbow w/o block.....	#8-44077
Complete cbow cutter block j3 j5 .....	#8-44272

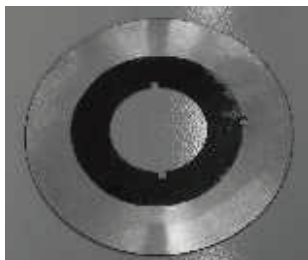

Cutting Blade	
5-1/2" .....	103-0002V
4-1/2" .....	103-0003

# CUTTER SIDE VIEW

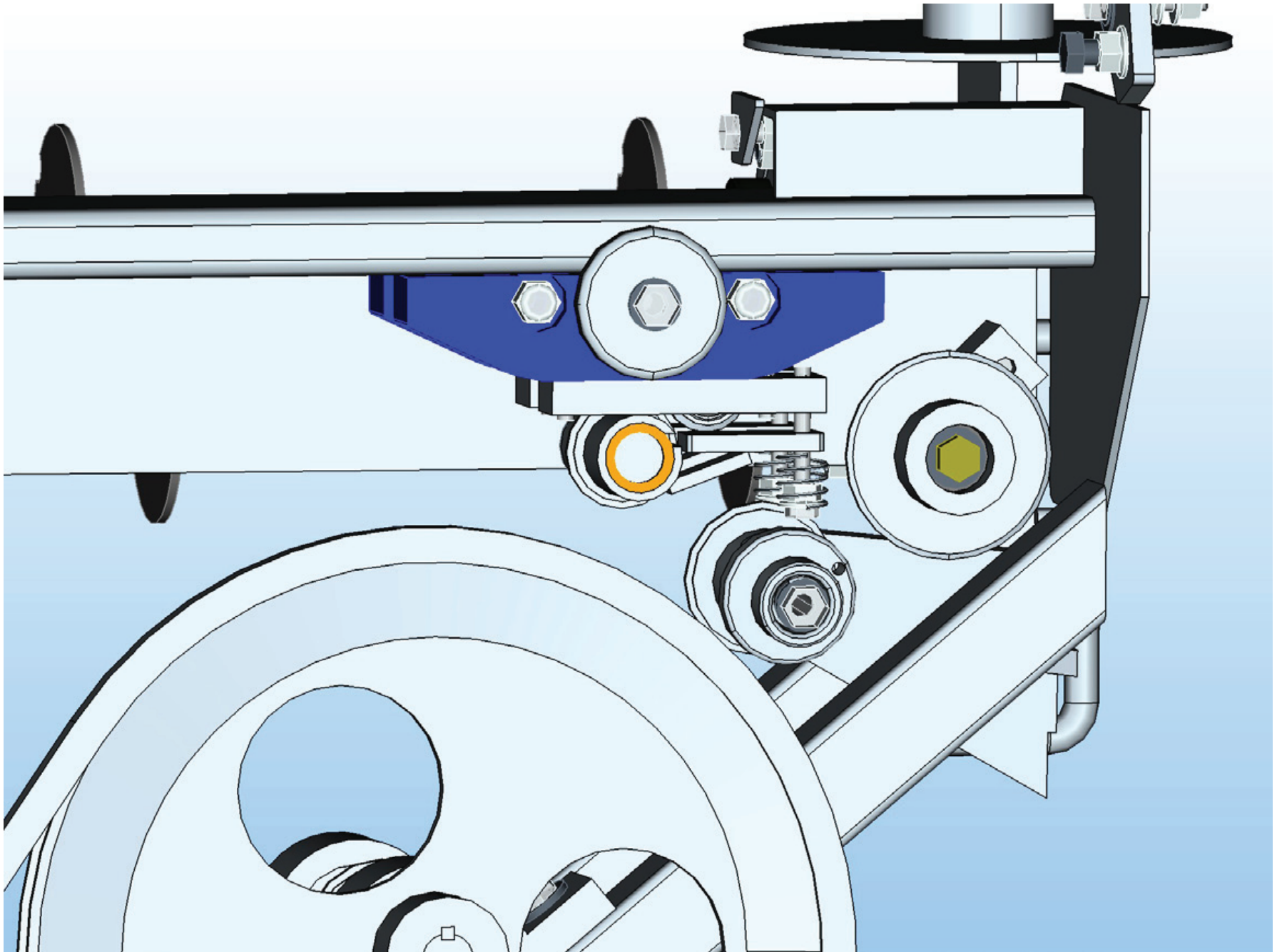

# CIRC CUTTER COMPONENTS

Please see next page for component list.

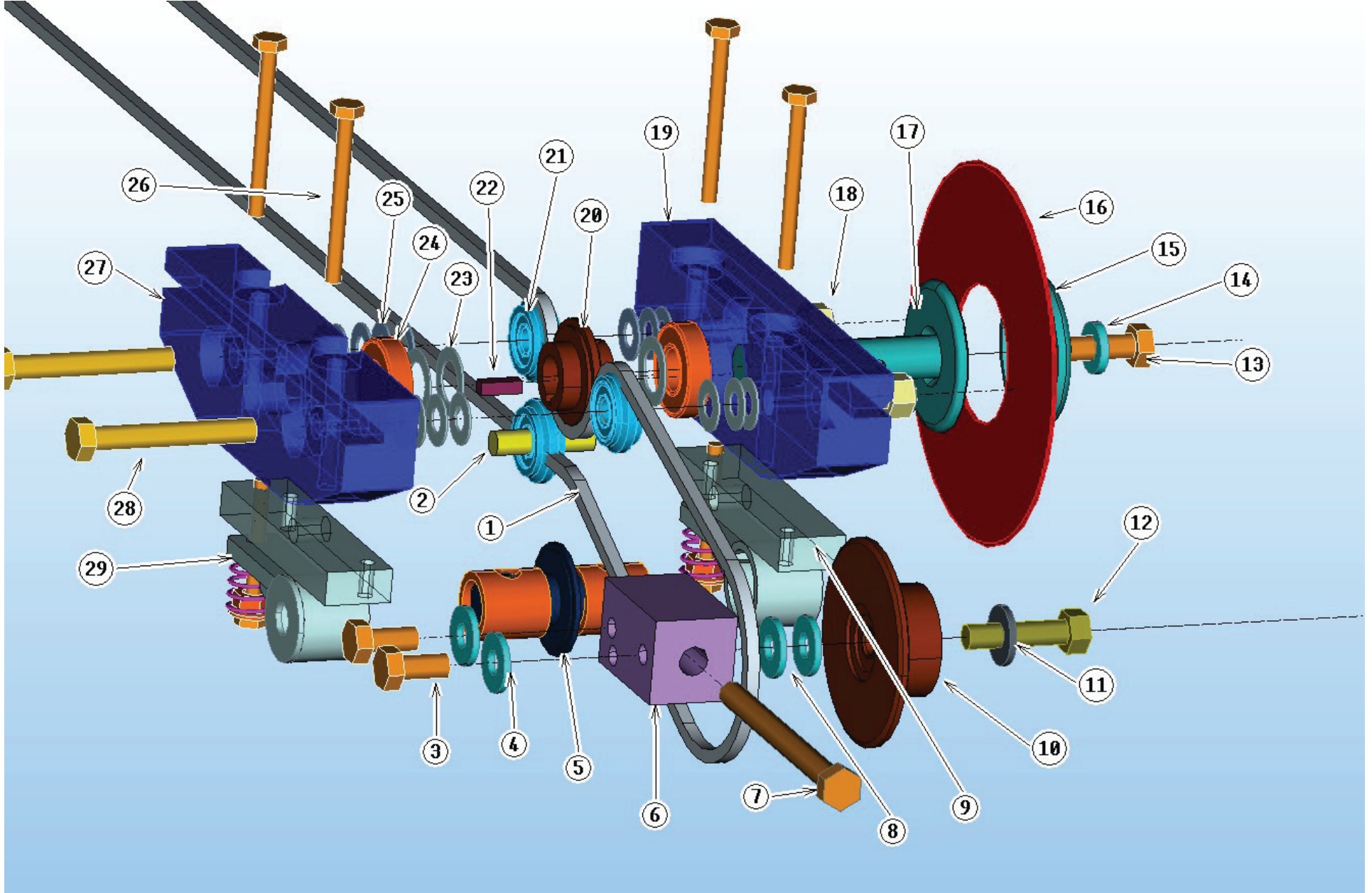

# CIRC CUTTER COMPONENTS

Key	Description	Part Number	Key	Description	Part Number
1	RnR cutter chain 12	103-0006	14	Washer 3/8 x 3/4	003-0113
	RnR cutter chain xl	103-0019	15	Blade mt washer	8-8080
	Cutter chain con link	105-0068	16	Blade carpet circ 5-1/2	103-0002V
	Circular cutter complete w/clutch, no blade	8-46897	17	Blade mandrel	8-8050
	Clutch kit, w/springs and sprckt shaft	8-55424	18	3/8 Steel lock nut unc	004-0087
2	CCC idler shaft	8-8200	19	Right cutter guide block	8-8020
3	3/8 X 3/4 hex bolt gr5 unc	001-0113	20	#3512W/5/8 hub sprocket	120-0005
4	Washer sae 3/8	003-0008	21	Chain idler	8-8100
5	Ccc slip shaft asm	8-8160	22	Key 3/16 x 5/8	8-44705
6	Tightner block	8-5330	23	Wshr 5/8 x 1 blade shaft shim	003-0101
7	3/8 X 4 hex bolt full thread gr5 unc	001-0255	24	Bearing r10zz 5/8	006-0054
8	Washer sae 3/8	003-0008	25	Wshr flat spacer 3/8 x 3/4 x 1/32 (shim)	003-0059
9	Right clutch clamp	8-8120	26	1/4 X 2 1/2 hex bolt gr5 unc	001-0091
10	Sprcket idlr 3523 w/bearing	120-0067	27	Left cutter guide block	8-8030
11	Washer sae 3/8	003-0008	28	3/8 X 2 1/2 hex bolt gr5 unc	001-0120
12	3/8 X 1 1/2 hex bolt l9 unc	001-0207	29	Left clutch clamp	8-8240
13	3/8 X 1 hex bolt gr5 unc	001-0114			

# CUTTER BLOCK COMPONENTS

Cutter block from Clayton Homes Rack n Roll, 7-67820.

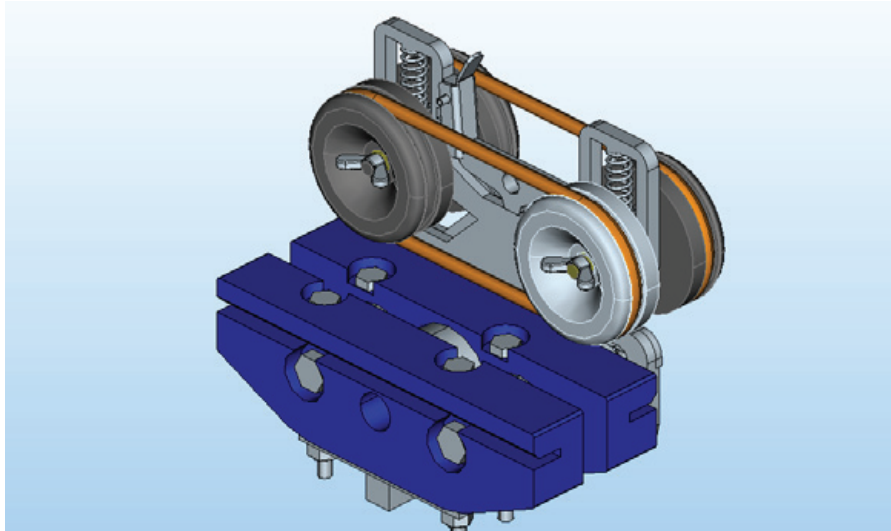

Key	Description	Item_no
1	Complete cbow cutter&block	8-44271

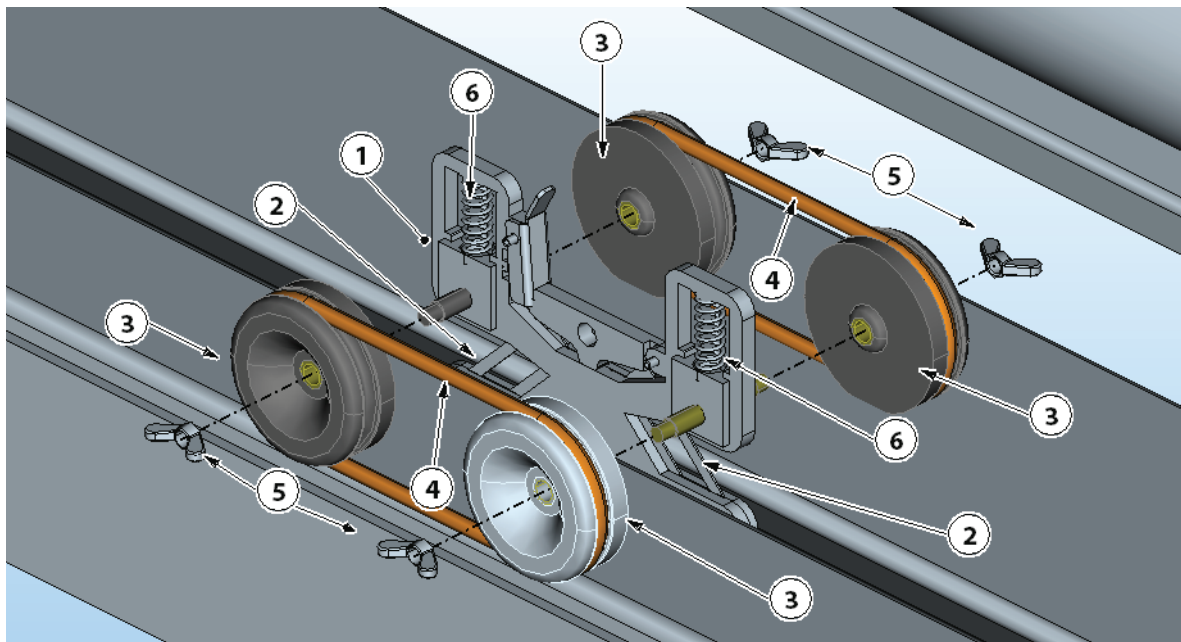

Key	Description	Item_no
1	Double-bladeholder-crossbow weld	8-44092
2	Cutting blade - .017 X2-1/4 x 23/32	103-0012
3	Blade holder wheel	7-51083
4	O-ring 1/4 x 15-7/8 orange	112-0009
5	Nut wing 1/4	004-0055
6	Spring-.055Wire x.510Od x1.625 X.175P	119-0032

# CUTTER BLOCK COMPONENTS

Cutter block from Clayton Homes Rack n Roll, 7-67820.

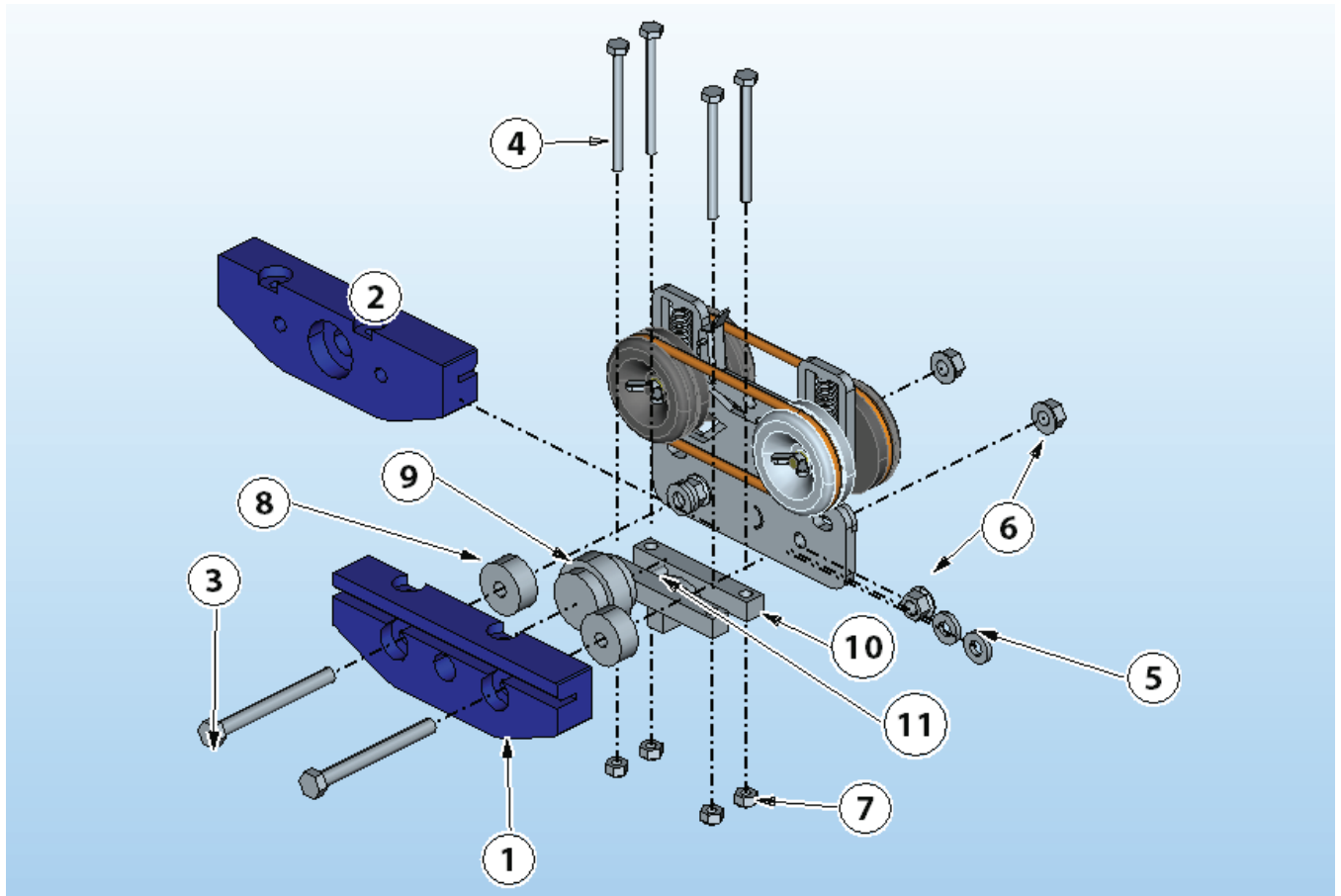

Key	Description	Item_no
1	Left cutter guide block	8-8030
2	Right cutter guide block	8-8020
3	3/8 X 3 1/2 hex bolt gr5 unc	001-0123
4	1/4 X 3 hex bolt gr5 unc	001-0092
5	Washer 3/8x3/4x11g	003-0113
6	3/8 Flange nut gr5 unc	004-0015
7	1/4 Nylon lock nut gr5 unc	004-0042
8	White plastic idler wheel	8-44273
9	White plastic chain skid	8-44274
10	Cbow cblock chain mt unit	8-44082
11	Clevis_pin_1/4dia. X 1-5/8	113-0063

# CIRC CUTTER DRIVE COMPONENTS

Please see next page for component list.

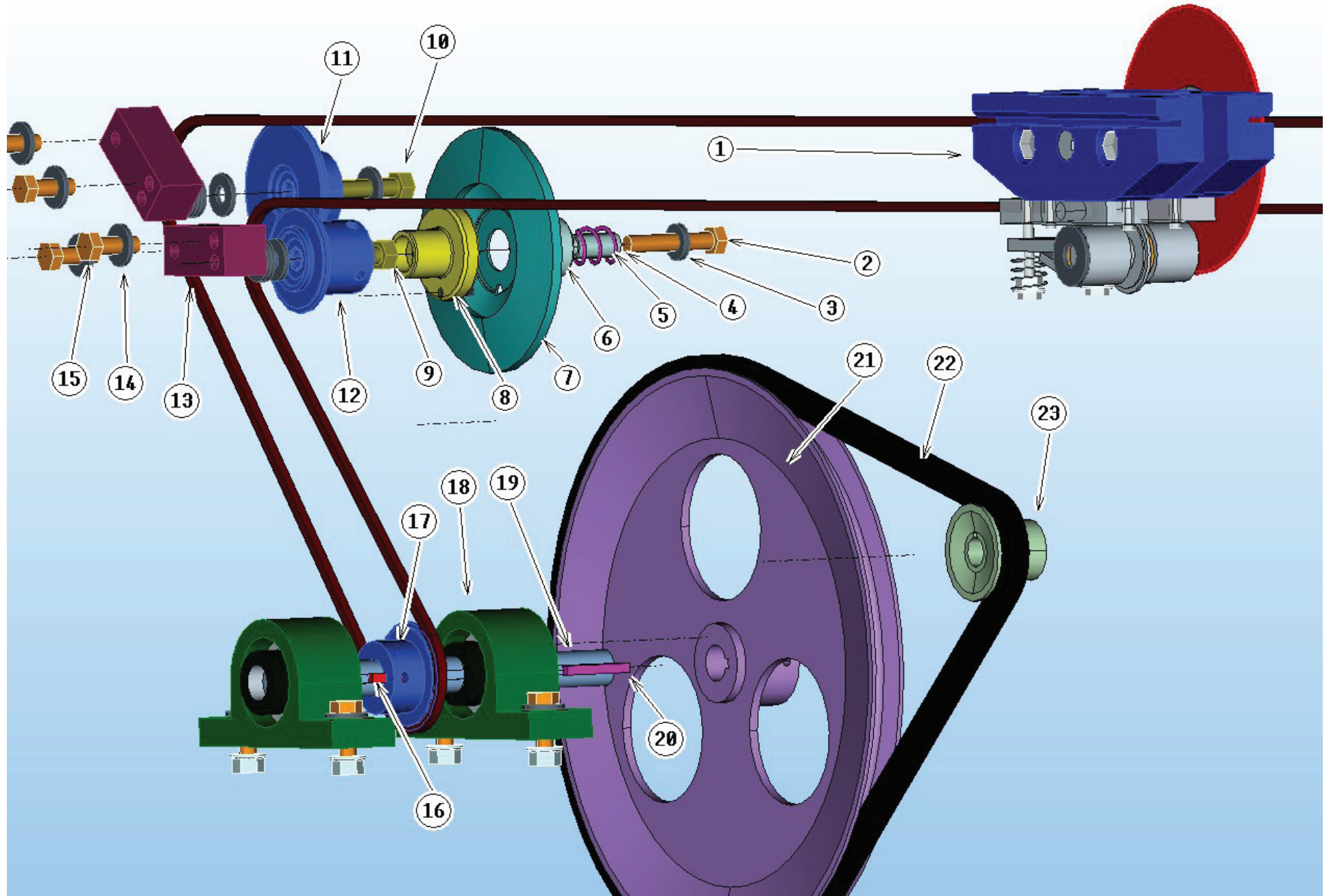

# CIRC CUTTER DRIVE COMPONENTS

Key	Description	Part Number	Key	Description	Part Number
1	Circular cutter with 5-1/2" vidir	8-55245	12	Sprocket 3517 sharp w/ 3/8 bearing ivc15	8-44691
2	3/8 X 2 hex bolt gr5 unc	001-0119	13	Sq block tightner mt	8-44687
3	Washer 3/8x3/4x11g	003-0113	14	Washer sae 3/8 (.406X.813X.080)	003-0008
4	Sharpener base sleeve	8-43421	15	3/8 X 3/4 hex bolt gr5 unc	001-0113
5	23/32Od x 1l x .085Wd x .375P com spring vid07017	119-0014	16	Key 3/16 x 1	8-53390
6	Sharpener hub insert	8-43420	17	35-17-B-hub	120-0013
7	5" Sharpener wheel	8-44692	18	Pillow_block_204-012d1	006-0031
8	Sharpener base hub	8-43419	19	Long drive shaft	8-44689
9	3/8 X 1 1/2 hex bolt l9 unc	001-0207	20	Key, 3/16 x 1,1/2	8-53391
10	3/8 X 1 1/2 hex bolt l9 unc	001-0207	21	12 In pulley unit	8-44690
11	Sprocket idlr 3523 w/1614rs	120-0067	22	Belt a43	102-0035
	3/4 Hp motor, 3 ph, 208v (not shown)	407-0006	23	Pulley steel as17 x 5/8 (browning)	115-0097
	3/4 Hp motor, 1 ph, 220v (not shown)	407-0003		R n r motor cover (not shown)	Jul-80



# R10R/ARROW CHAIN ROUTING

R10R and Arrow chain routing diagram for circular cutter

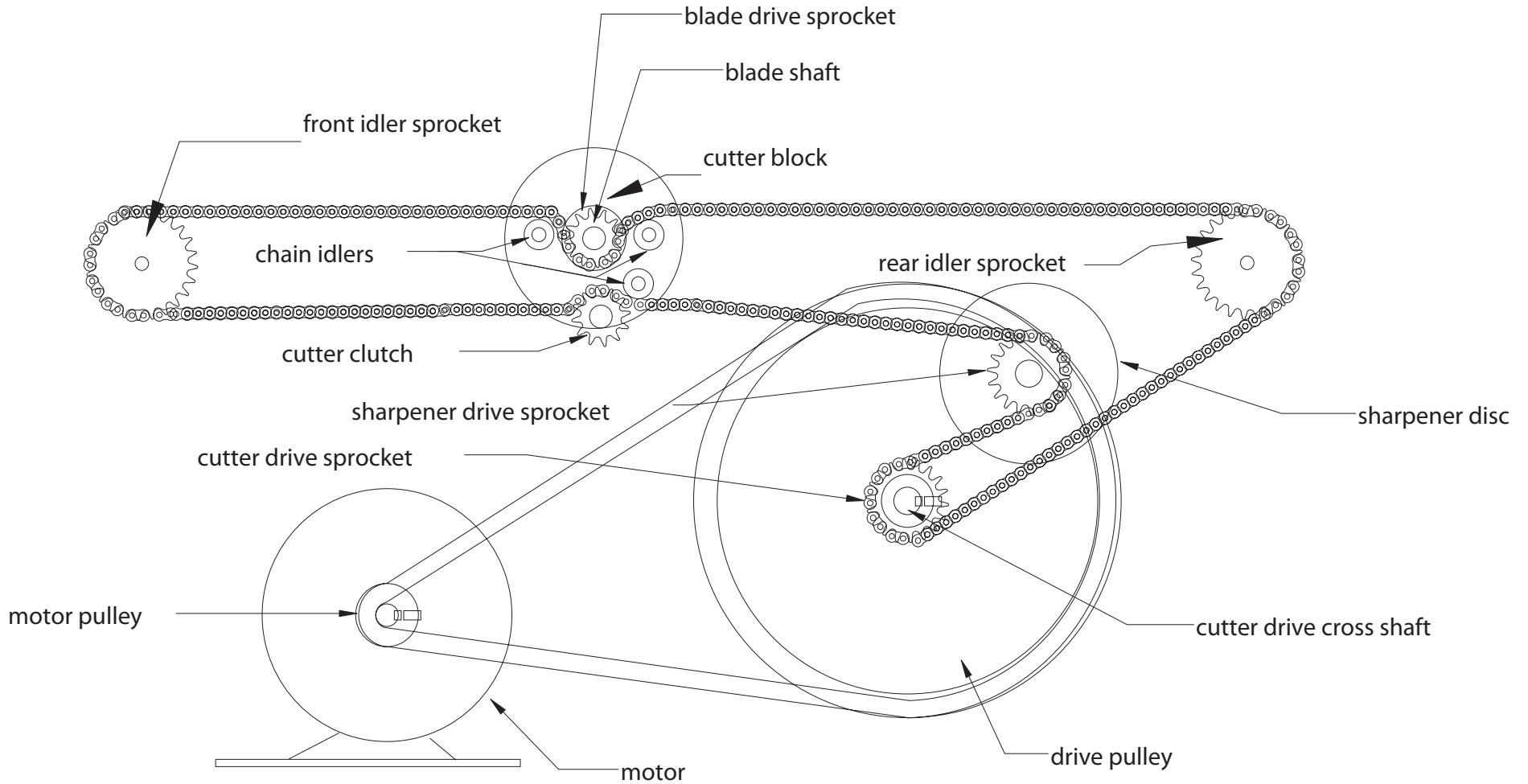

# R10R CUTTER REAR VIEW

Rear View of cutting blade engaging  
sanding disc

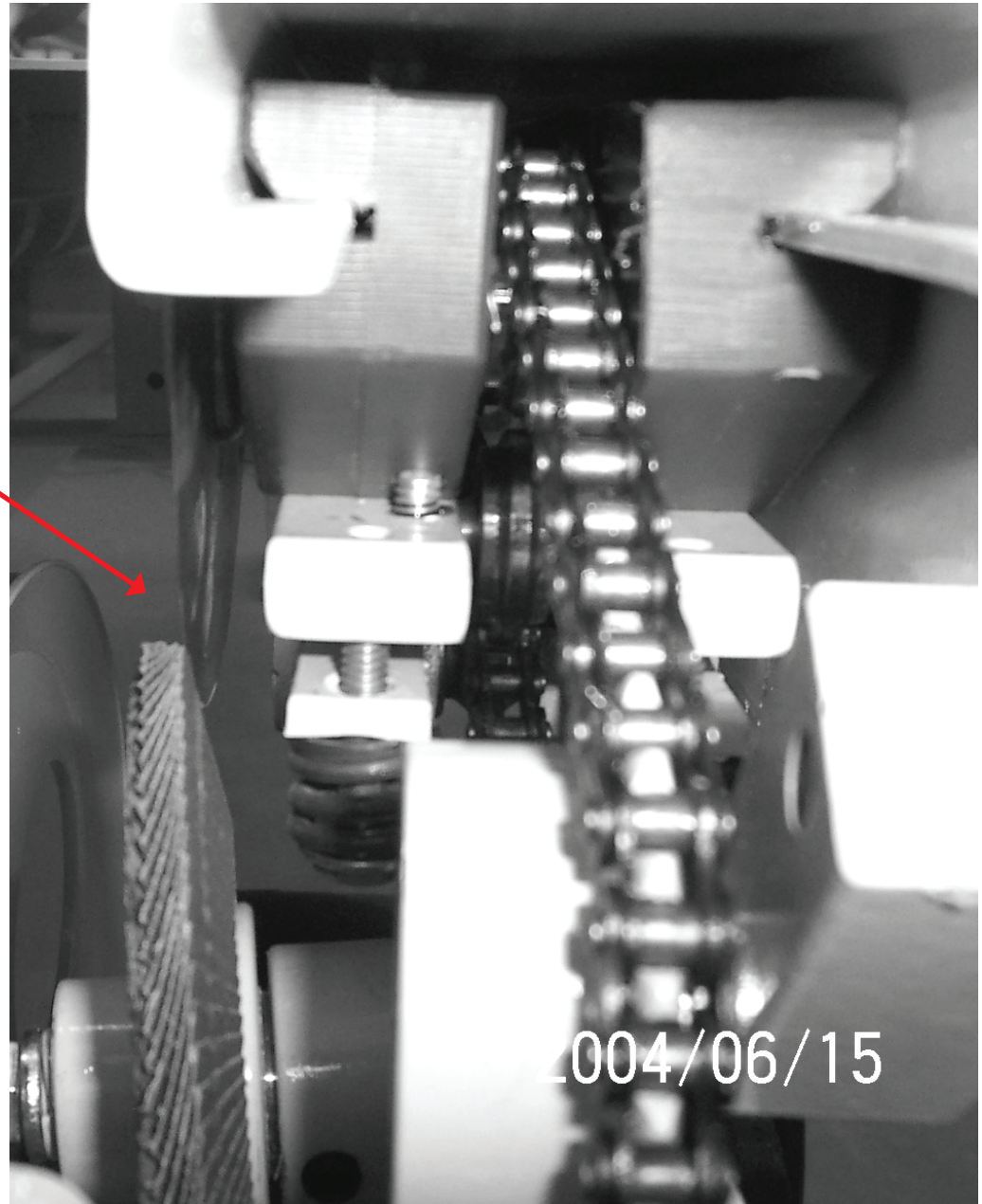

# ROLLER DRIVE COMPONENTS

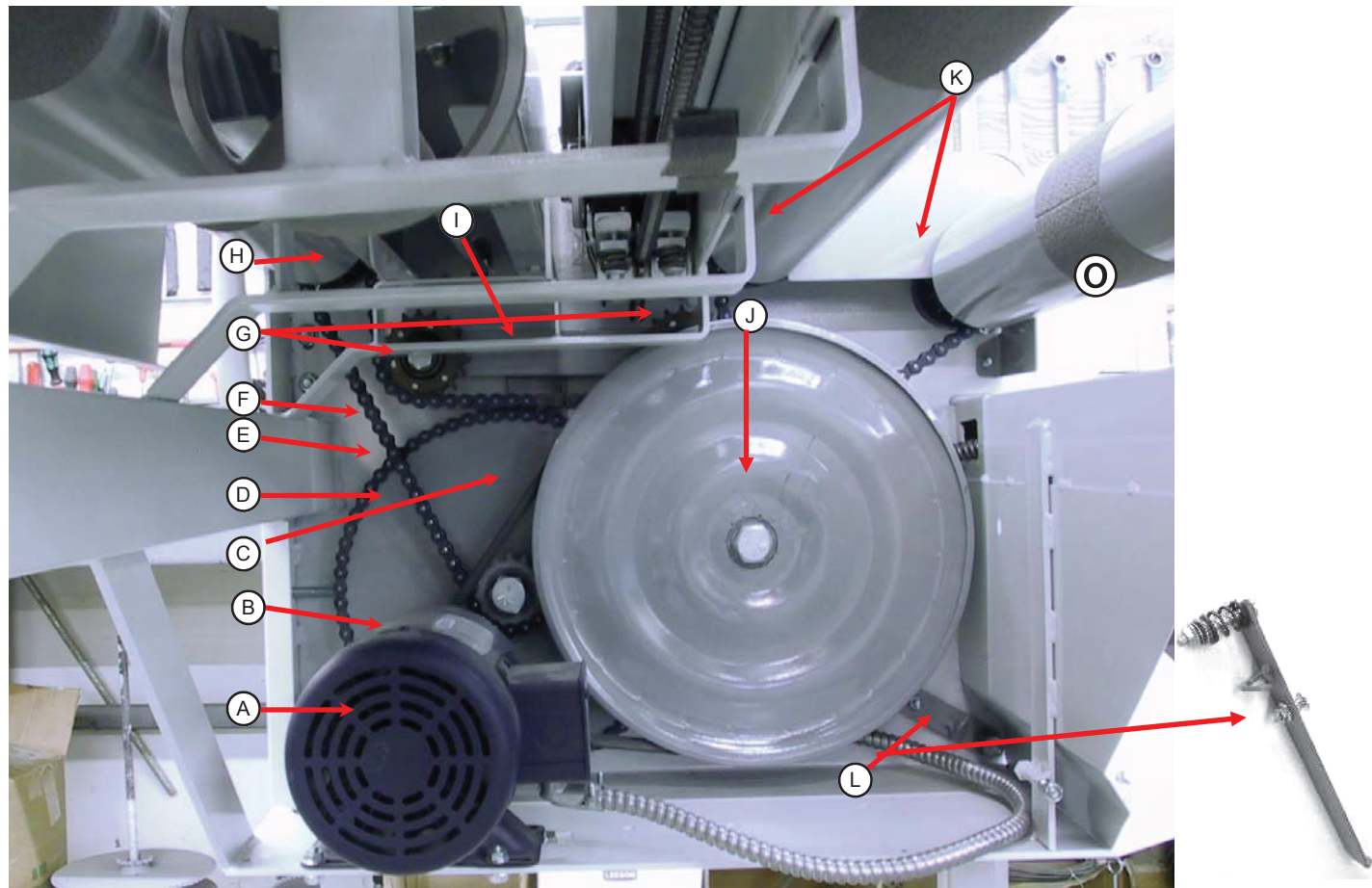

Description .....	Part number
A. 1/2 HP Motor 3PH 208V.....	407-0002
B. Motor pulley 5/8" x 2 1/2" .....	115-0022
C. V belt A -47 .....	102-0039
D. Dbl. Speed reduction sprocket.....	7-5640
E. Speed reduction chain 40".....	7-66878
F. Roller drive chain 70" .....	105-0002
G. Drive chain idlers (2) .....	120-0199

Description .....	Part number
H. Right side drive roller sprocket 40X17.....	120-0037
I. T chain tightener idler mount.....	7-5590
J. Speed reduction pulley and sprocket.....	7-66879
K. Left side drive roller sprockets (2) 40 X16....	120-0033
L. Foot switch lever.....	7-6060
Spring for foot switch lever .....	119-0013
M. Foot cable Reg. 15' 4".....	400-0023
N. Foot cable Reg. XL 17' 4".....	400-0024
O. Gripper tape (safety walk).....	117-0005

# ROLLER DRIVE COMPONENTS

Rnr drive chain tightner asmb..... #7-50646

Assembly of 7-6060 foot switch lever

1 X spring com .085 X .715 X 1-1/2.....#119-0013

2 X bolt hex 1/4x1 gr5 unc.....#001-0087

1 X bolt hex 1/4x2 gr5 unc.....#001-0089

3 X washer 1/4x5/8x1/16 cz.....#003-0005

3 X nut flange 1/4 gr5 unc.....#004-0013

# HOLD DOWN & PINCH ROLLER COMPONENTS

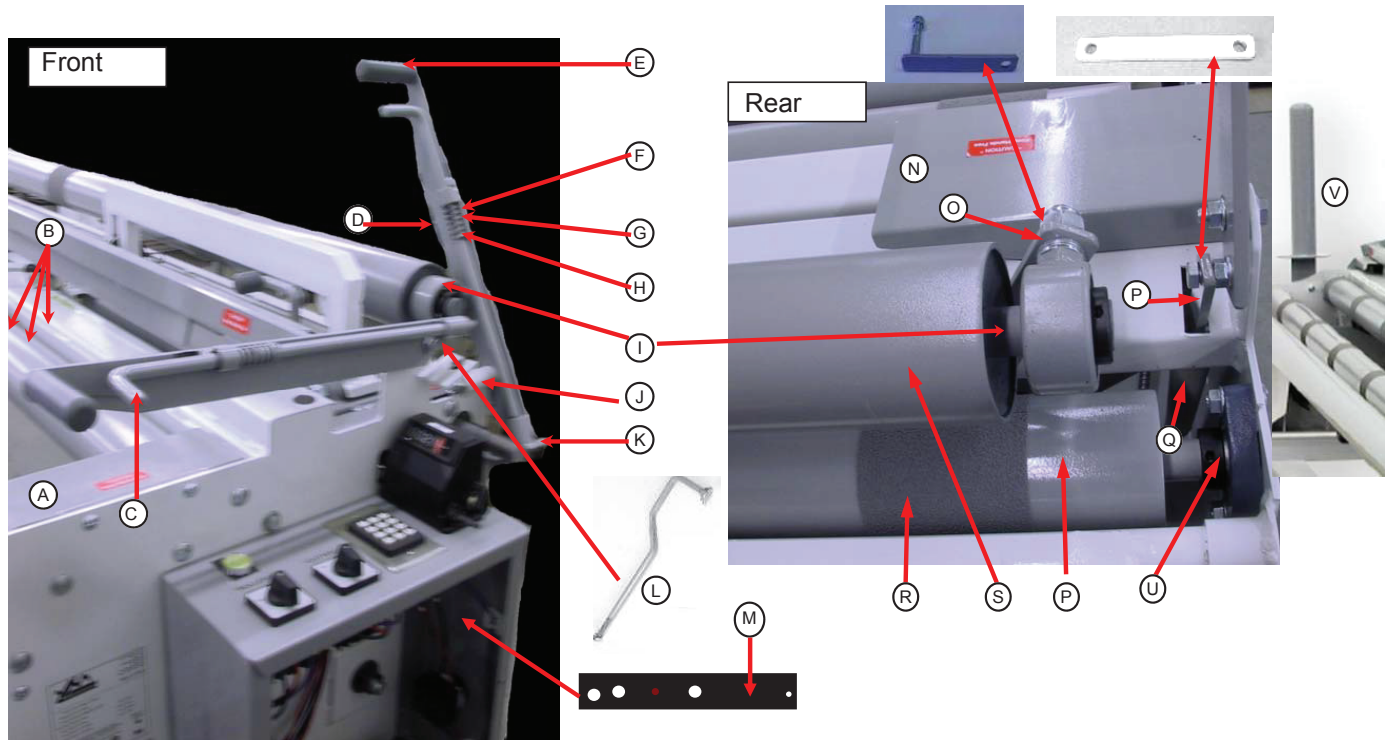

- Bolt on cutter hold down latch plate ..... #7-76360
- Hold down spring tightener (bottom of q) ..... #7-53861
- Pulleys..... #115-0096 & 115-0050

Description .....	Part number
A. Chain cover (front left).....	7-5500
B. Drive rollers (3) .....	7-48675
C. Latch Throw Rod .....	7-5750
D. Pinch Roller Lift out Handle .....	7-50642
E. Plastic Handle .....	7-1170
F. Latch Spring 1/2" X 1 1/2" .....	119-0013
G. Latch Throw Rod Washer .....	003-0016
H. Latch Rod Roll Pin 3/16" x 3/4" .....	113-0031
I. Pinch Roller Bearing Sleeve with Stud [includes bearing w/ lock collar] .....	7-50644
J. Chain cover (front right).....	7-5480
K. Pinch Roller Latch Striker Plate.....	7-5000
L. Cutter hold down safety switch activator rod.....	111-0051
M. Cutter hold down Safety switch lever .....	7-67035

Description .....	Part number
N. Rear Cutter Cover.....	7-6080
O. Rear Pinch Roller Hinge.....	7-3630
P. R&R Hold Down Spring Bracket.....	7-6260
Q. Spring Ext. 1.25 O.D. X 13.75 # VID 1312.....	119-0018
Hold down spring tightener .....	7-53861
R. Gripper tape .....	8-53804
S. Pinch roller (top) .....	7-3750
T. Pinch roller (bottom) .....	7-3470
U. 1" Bearing Pillow Block with bearing.....	006-0044
V. Poly Wrap dispenser .....	7-5030
Plastic hand wheel (see page 49 - fig 1) .....	7-5450
Plastic hand wheel mounting pipe (see page 49 - fig 1)....	7-5440
Pinch roller center support bracket.....	7-46591
Pinch roller kit.....	7-46592

# COUNTER COMPONENTS

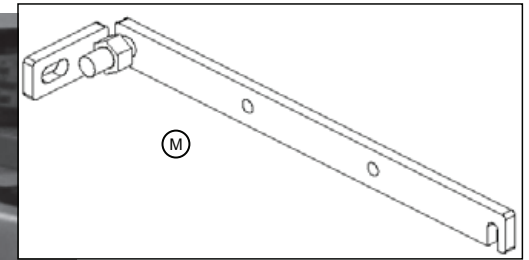
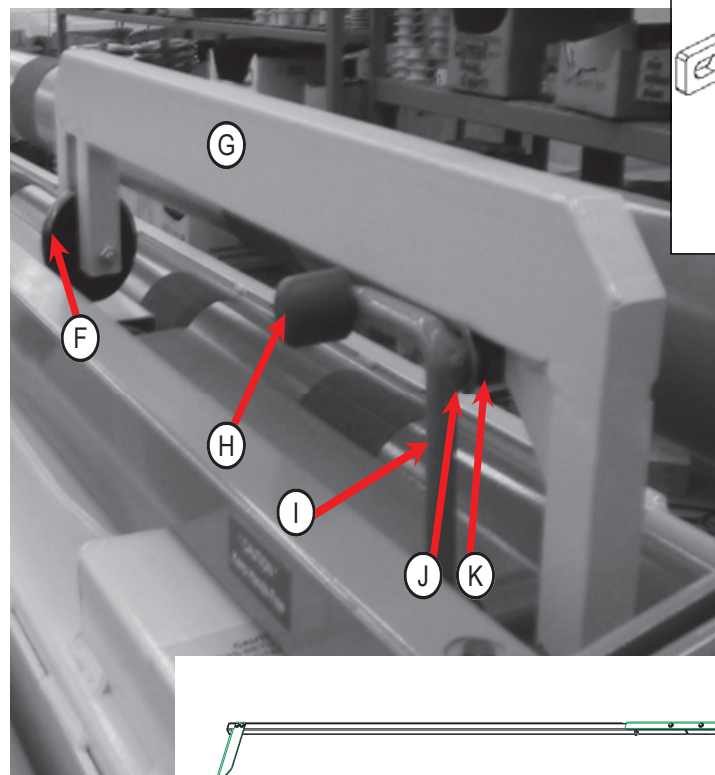
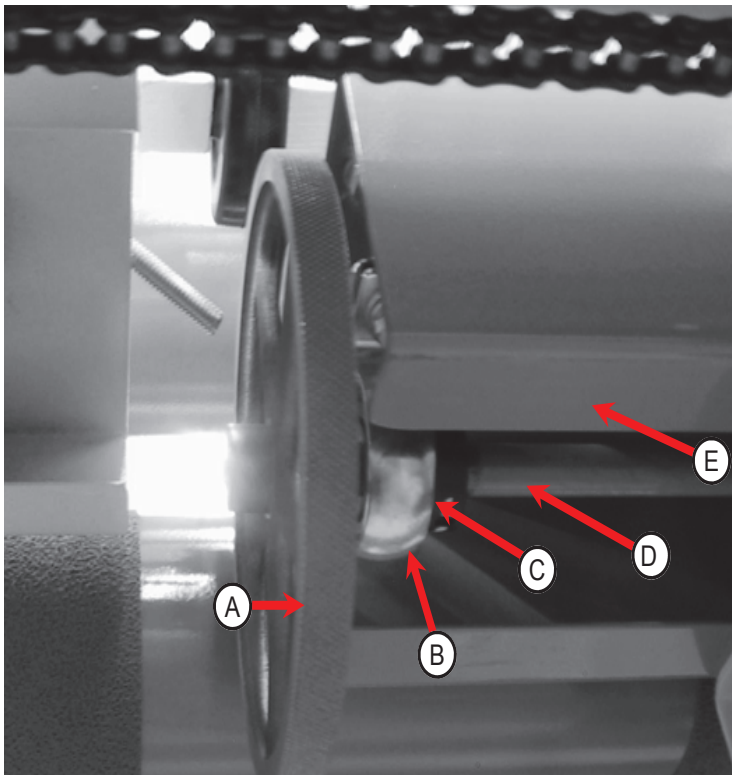

**NOTE:** When changing over from LRG-DIG counters to new style, they need to replace the Shaft and Counting wheel as well.











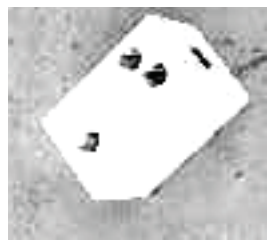

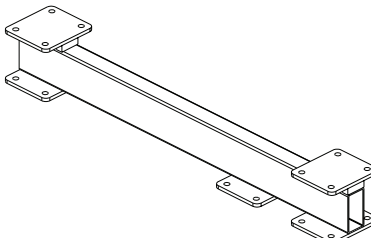
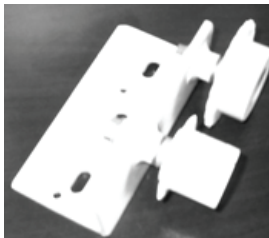

Description	Part number
A. 6" Counting wheel .....	402-0034
B. Pillow block w/o bearing.....	006-0052
C. 1/2" 201 Bearing .....	006-0010
D. Counter shaft, new style.....	8-62061
old style.....	8-49723
E. Counter table insert .....	402-0046
F. Counter hold down wheel.....	104-0002
G. Counter hold down arm.....	7-61348
H. Counter hold down lift out plastic knob .....	7-3250
I. Counter hold down lift out lever.....	7-56091
J. Counter hold down lift out lever bushing .....	007-0017
K. Counter hold down lift out lever push nut .....	004-0094
L. Trumeasure 3900 counter.....	402-0003
M. Machine latch mounting bracket.....	7-53456

Description	Part number
N. Electrical break-away cord 208V, 3PH, 11ft.....	2-52863
O. Bumper 2pc. asmb 12ft.....	7-75402
Caster 6" swivel brake (not shown) .....	104-0009

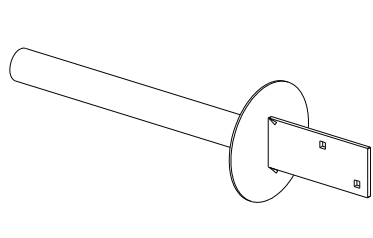
Description (not shown)	Part number
A. Counter 2:3 ratio for 6" wheel .....	402-0001
B. Counter 1:1 ratio for 4" wheel.....	402-0066
C. 4" Counter wheel.....	402-0032
Carousel receptacle twist plug.....	408-0032
Plug - male, 208V, twistlock.....	408-0037
D. 10" counting wheel .....	7-40099

# MISC COMPONENTS

				
Front cutter idler mount 111-0112	Rear cutter idler mount 111-0042	RXL pinch rlr ctr spprt 111-0205	3rd roller kit 7-55496	Cutter hld dwn sprg brk 7-6260
				
Grooved 6" caster wheel 104-0040 (for J & D Floor Track use 998-66372)	Un-grooved 6" caster wheel - smooth/hard 104-0006	Wheel Extension 7-5140	R5R & R6R Ctr tght angle 7-48058	Foot switch actvtr lvr 7-6060
				
Poly wrap dispenser 7-5030	Ctr hld dwn pvt blt kt 111-0235	Festoon mnt L brckt 7-5270	Floor Track (15ft Floor Track / 12ft Goods) FLRTRK6 6' 7" FLRTRK10 10' 405-0013 20'	Floor track expansion anchor - 001-0001 Floor track mounting screw - 002-0049 Floor track end stop - 7-51060

# MISC COMPONENTS

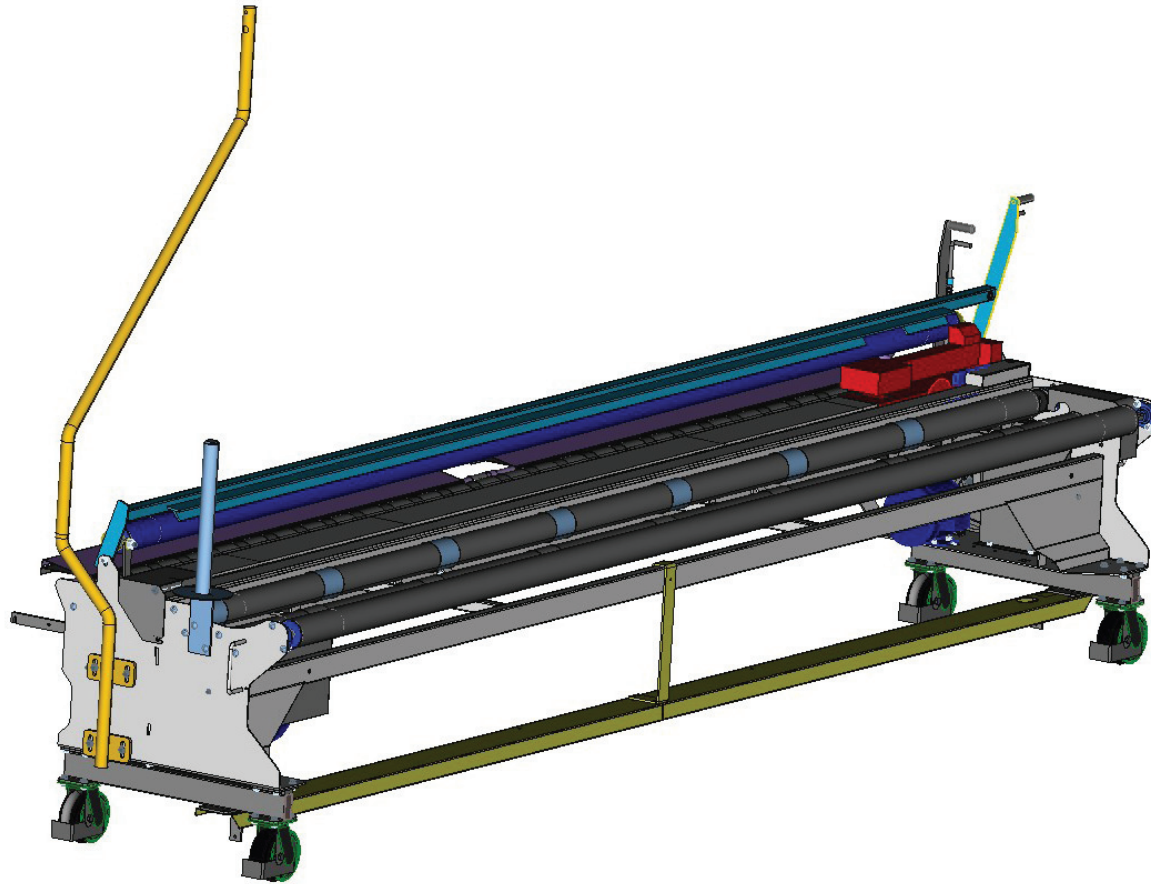

Description	Part number
1...Festoon trolley .....	405-0014
2...Push and pull festoon trolley.....	405-0001
3...Festoon track end stop .....	7-51060
4...Festoon cord mounting brackets.....	405-0004
5...Festoon cord track joiner .....	405-0012
6...Festoon strain relief connector .....	405-0005
7...Festoon cord track end clamp.....	405-0006
8...Machine latch with mounting bracket.....	7-53456

Not shown:  
 RnR drop table - 201" .....7-50995  
 RnR drop table - 177" .....7-53845

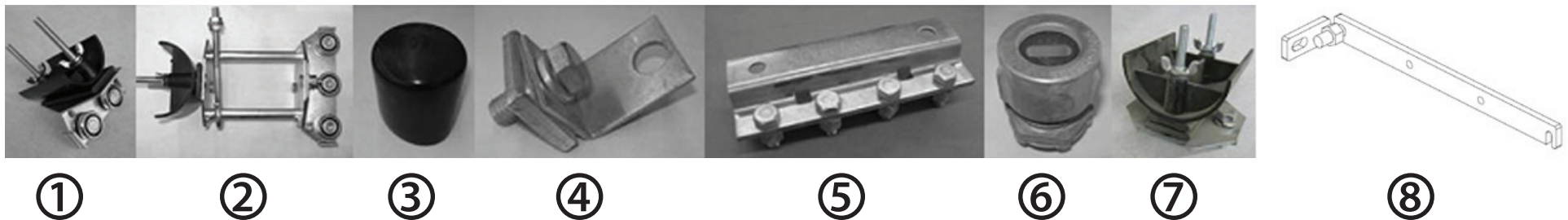



# CONTROL COMPONENTS

Please see next page for component list.

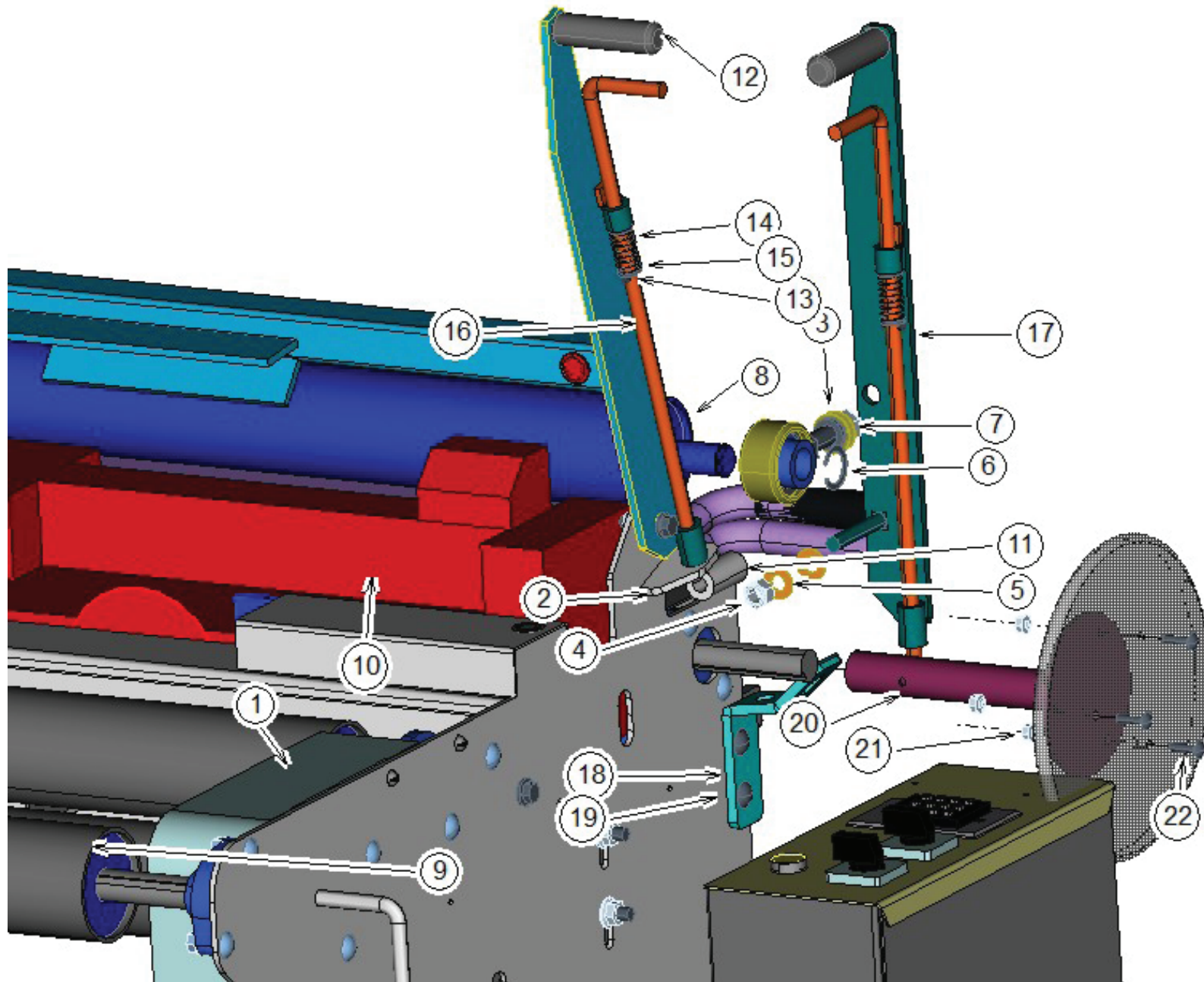

# CONTROL COMPONENTS

Key	Description	Part #
1	Chainguard unit	7-5500
2	RnR bolt on chd catch kit	7-76360
3	Wshr flat brass 5/8 x 1-1/4 x 1/16	003-0098
4	1/2 Nylon lock nut gr5 unc	004-0046
5	Wshr flat brass 1/2 x 1 x 1/16	003-0123
6	Ring snap ext 1" (cs100)	116-0026
7	RnR pnchrllr brng asm	7-50644
8	RnR pnchrllr top	7-3750
	RnR pnchrllr bottom	7-3470
9	RnR frame roller (3)	7-48675
10	Truemeasure 3900 counter ft/in	402-0003
11	RnR bolt on hinge	7-60728
12	Chd plastic handle	7-1170
13	Pin roll 3/16 x 3/4	113-0031
14	Spring com .085 X .715 X 1 1/2	119-0013
15	Washer 17/32 x 3/4 x 1/8	003-0021
16	Pr handle latch rod	7-5760
17	RnR pnchrllr lever asm	7-50642
18	Pr handle latch plate	7-5000
19	3/8 X 1 cg bolt crg gr5 unc	001-0042
20	RnR inchwheel hub	7-5440
21	1/4 Flange nut gr5 unc	004-0013
22	1/4 X 1 bolt crg gr5 unc	001-0019
	RnR 12Ft. droptable 2pc asmb	7-53845
	RnR cutter hold down 12 asmb	7-50641
	RnR cutter hold down 15 asmb	7-50959

# ROLLER DRIVE COMPONENTS

Please see next page for component list.

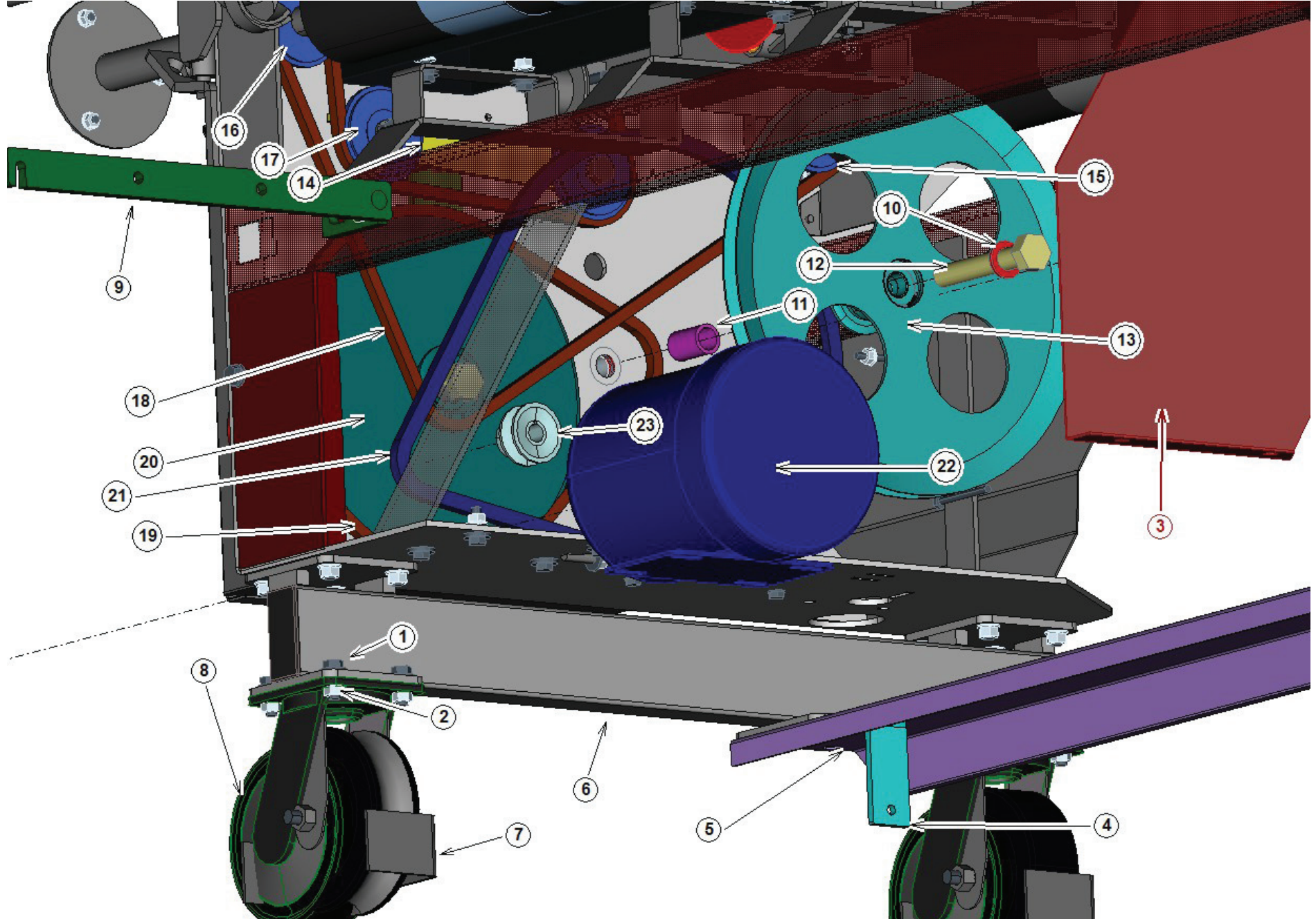

# ROLLER DRIVE COMPONENTS

Key	Description	Part #
1	3/8 X 1 hex bolt gr5 unc	001-0114
2	3/8 Flange nut gr5 unc	004-0015
3	Inner front cover	7-5230
4	RnR foot cable bracket right	7-5160
5	Cable guard right	7-5322-p01
6	RnR caster mount weld	7-5140
7	Caster 6" rigid w/toe guard grooved	104-0040
8	Caster 6" swivel cast core hd	104-0018
9	CnR crsl latch asm	7-49755
10	Wshr flat 3/4 x 1-1/4 x 1/8	003-0032
11	RnR pulley spacer	7-50648
12	3/4 X 4 1/2 hex bolt gr5 unc	001-0180
13	Asmb, RnR pulley sprocket	7-66879
14	Chain tightner unit	7-5590
15	40-16-B-hub	120-0033
16	40-17-B-hub	120-0037
17	Sprocket idler h40a18	120-0199
18	RnR drive chain 1	7-53860
19	RnR drive chain 2	7-53859
20	Asmb, RnR dble drive sprckt	7-66878
21	Belt a47	102-0039
22	Motor 0.5Hp 3ph 208/460v 56 (100913.00)	407-0002
23	Pulley cast ak25x5/8	115-0096

# MOTOR CHAIN DRIVE ROUTING

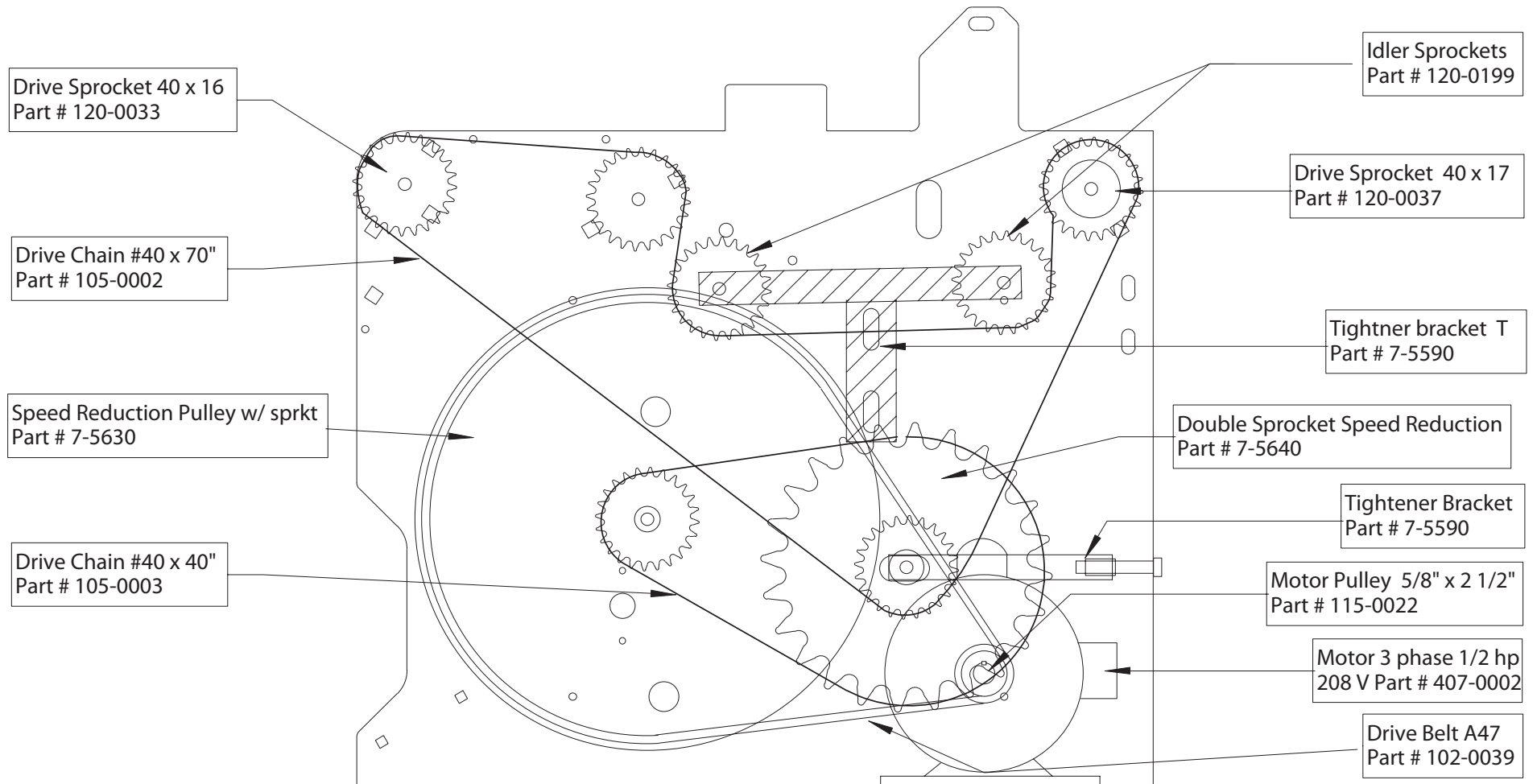

# MAINTENANCE

## Pinch Roller Latch Preventative Maintenance

1. Remove Nylon Lock Nut & replace with STEEL Lock Nut (A).
2. Tighten till latch lever is against machine (but still operates freely) (B).
3. Grease all the all the pivot points. (front and rear end of the machine).
4. Tighten all the pivot points to remove any slack. (If needed add some washers to take up the slack).
5. Check latch to ensure that it operates freely.
6. Raise pinch roller and ensure that the throw rod passes through striker plate by at least ¼" (C).
7. If the striker plate has only one hole replace it with a 2 hole striker plate. (as shown in the picture D).
8. If pivots are worn out and need to be replaced order a pinch roller latch kit part #7-50642

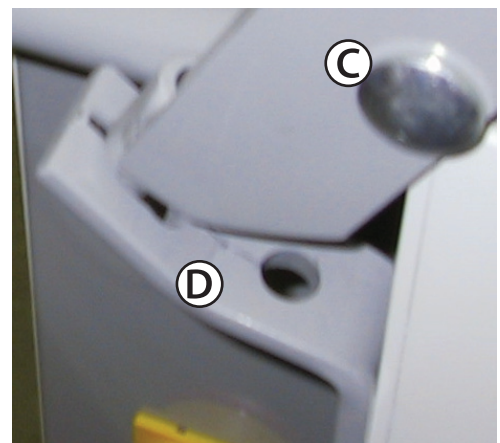
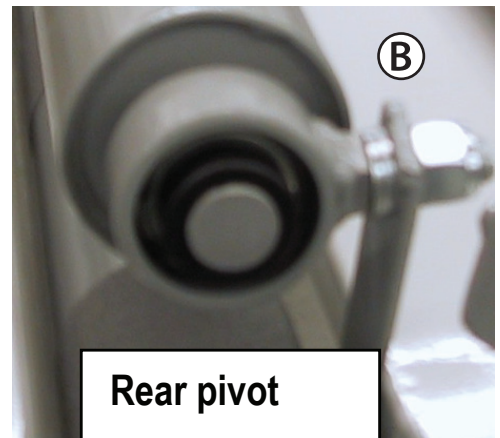
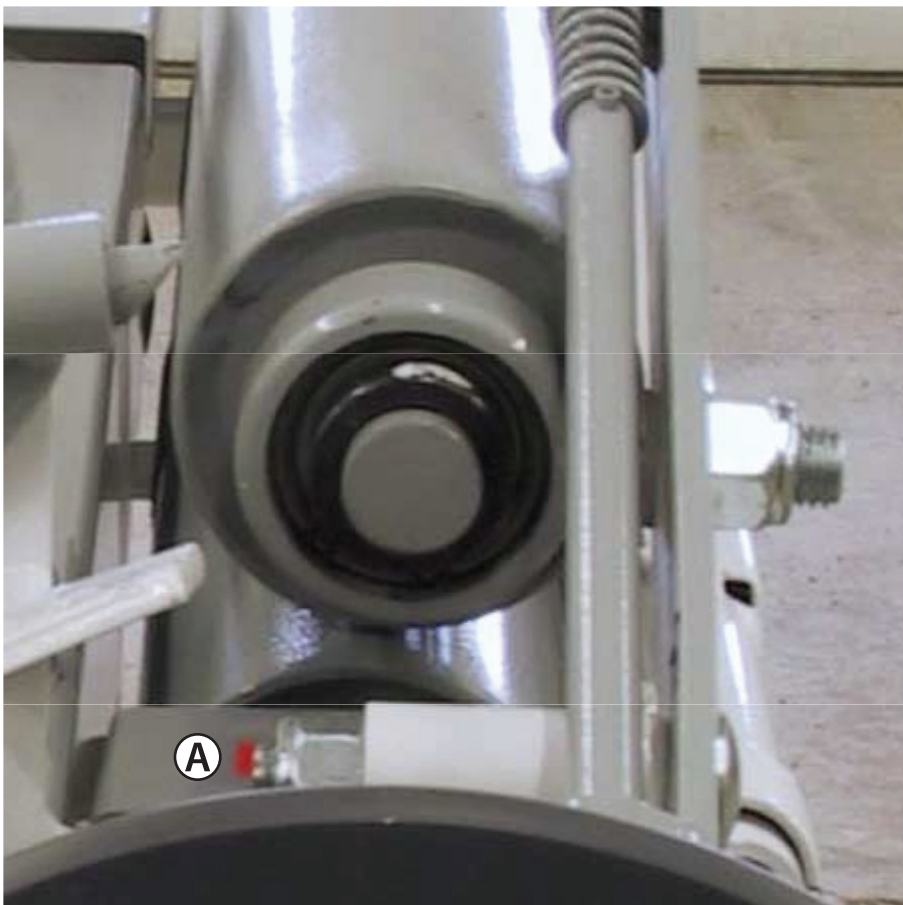

# **MAINTENANCE**

## **RnR CHDB Front Pivot Bolt Retrofit**

Applies to all model r5 May 1998 - May 2001, reflected in the serial number, R5\*-598-\*\*\*\* - r5\*-501-\*\*\*\*

### **RR Cutter Hold Down Bar front pivot bolt retrofit**

A recommended field up date for the pivot and latch on the RR cutter hold down bar pivot bolt. To be performed once only a regular Preventative Maintenance.

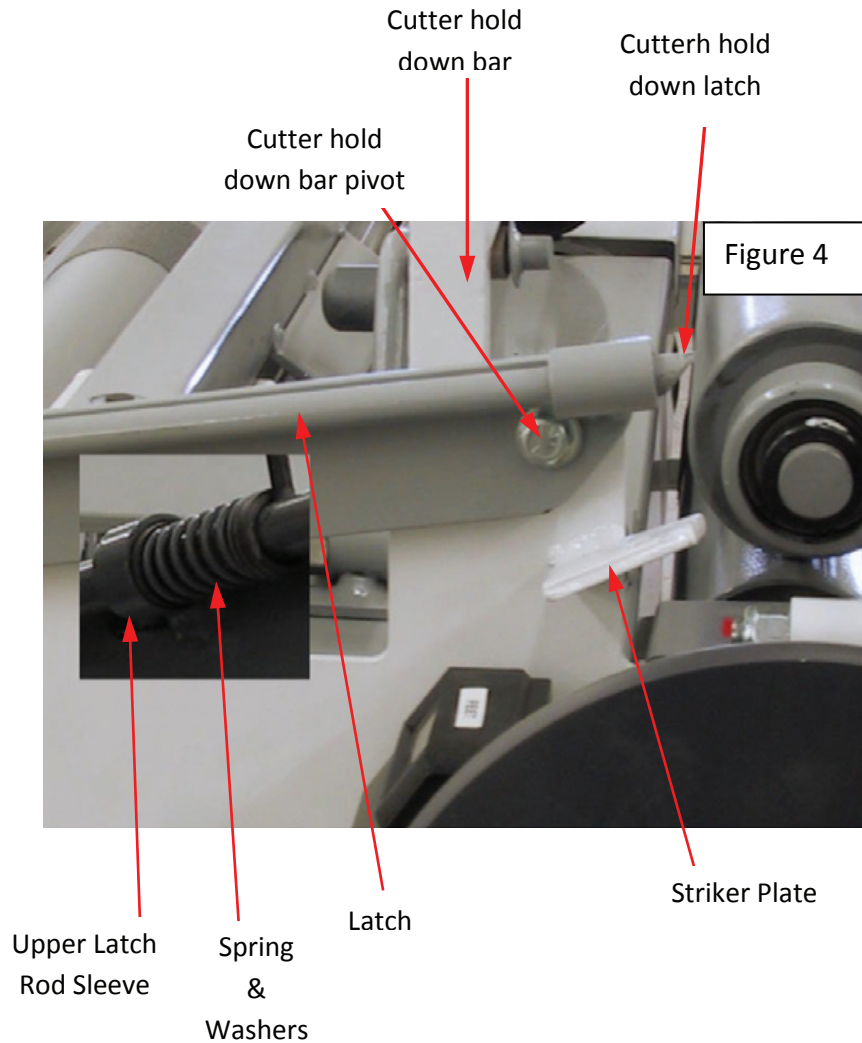

# MAINTENANCE

## Steps to install the front cutter pivot bolt retrofit kit.

1. Lower cutter hold down bar.
2. Remove front pivot bolt
3. Remove washers
4. Remove bushing
5. Install new bushing into pivot arm
6. Place small thick washer on to the new 3/8" x 1 1/2" bolt. See figure 5.
7. Place 3 spacer washers (1 thick 2 thin) over the bushing on the inside of the arm.
8. Align bushing with slotted hole in machine frame.
9. Install large flat washer between the inside of the arm and the machine frame.
10. Insert bolt with washer into the bushing and machine frame.
11. Insert slug into slotted hole on machine. See figure 6.
12. Place large flat washer over the bolt covering the slot and slug.
13. Install flange nut and finger tighten.
14. Slide cutter hold down bar to the left (away from the pinch roller but against the slug) See figure 6.
15. Tighten flange nut securely.
16. Install acorn nut and tighten securely.
17. Raise cutter hold-down bar and latch.
18. Check to ensure that latch rod projects a minimum of 1/8" through the striker plate. See figure 6B
19. If throw rod doesn't project 1/8" replace it with part #7-5750

Once complete, review the following inspection and operational tips with the machine operators/maintenance personnel:

Visually inspect the cutter hold-down mounting bolt on a regular basis. A loose bolt will prevent the safe operation of this latch.

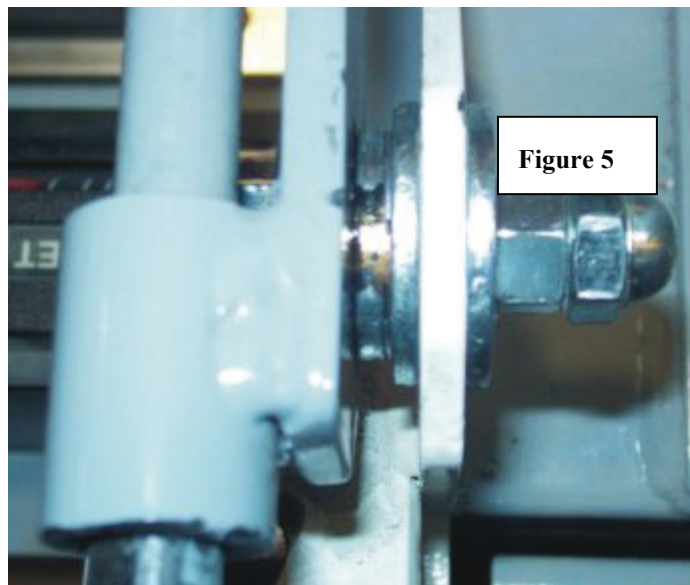



# MAINTENANCE

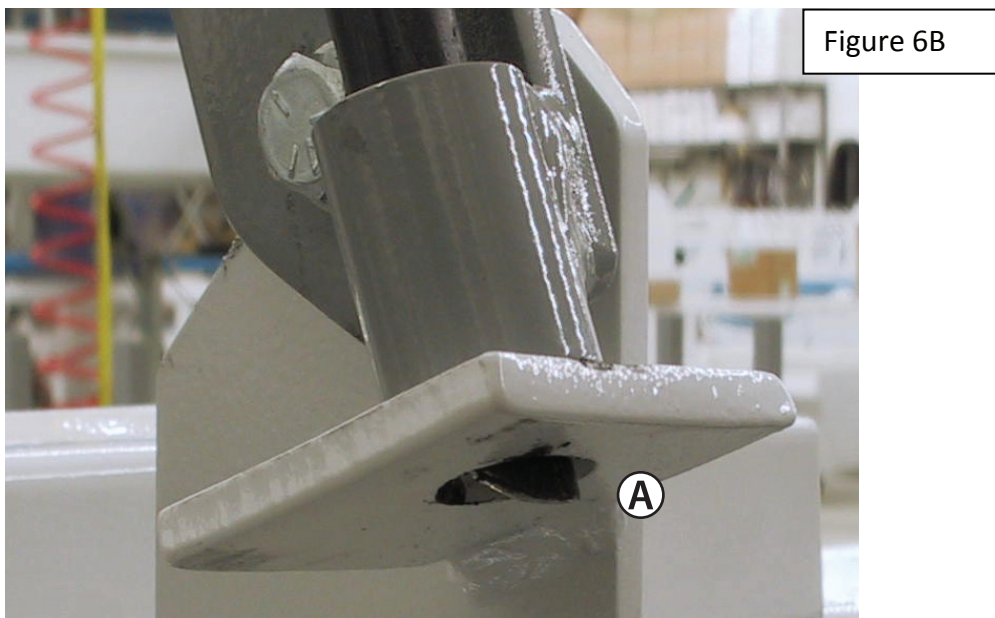
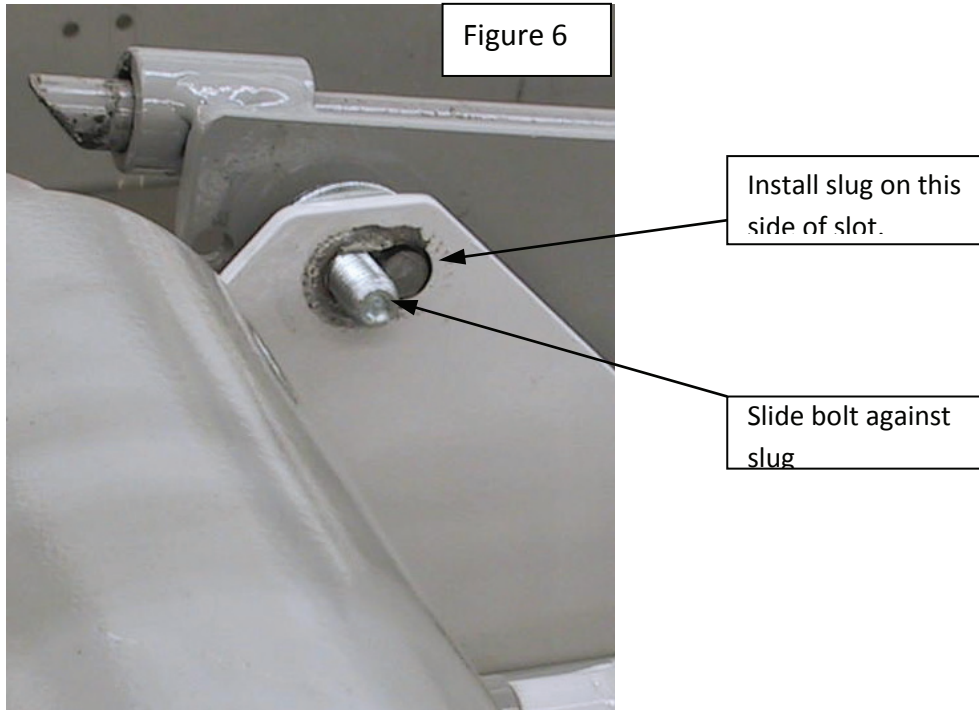

If distance of the throw is less than 1/8" the latch rod must be replaced with part # 7-5750

To replace the latch rod:

1. Remove roll pin see figure 1.
2. Slip latch rod out of the top arm.
3. Insert new rod part way.
4. Install the springs and washers in the correct order.
5. Install the roll pin.
6. Raise cutter hold down bar and check the length of travel.

# UPDATE KITS

## Changes by Serial Number R5 - R6

R5R has rod style safety switch cutter hold down bar.



Figure 43

Safetv switch rod part # 111-0051



Figure 44

Safetv switch part # 410-0039



Figure 45

Safetv switch lever part # 7-67035

R6R has magnetic sensors.



Figure 46 - 410-0114M



Figure 47 - 410-0014

Set of sensors without sleeves.



Figure 48

409-0020

# UPDATE KITS

## Changes by Serial Number R6 - 07/10/2000

All machines from this date forward changed from a Visonic key pad to an IEI key pad.

To make the change the inch button changed from 1 NO and 1 NC to having 2 NO contacts.

The foot cable switch changed from 1 NO and 1 NC to 2 NO and 2 NC contact points.

The IEI sink system operates off an open system and the Visonic operated on a closed system.

The IEI from Vidir has a special chip that enables the machine to run as long (+ 30 seconds) as unit is in operation.

The IEI key pad can be retrofitted with a full wave rectifier board (all replacements are equipped with them and sold as a unit) This is to stabilize the current to prevent nuisance tripping. This board has been standard equipment since about July of 2001.

The Visonic key pad used a sink circuit to reactivate itself. Key pad was programmed so that the aux output turned on (indicated by the yellow light) and stayed on 5 seconds longer than the main relay. Each time the foot cable or the roller inch button is toggled (blinking green light indicates this feature) the key pad is refreshed for as long as the timer is set for.



Figure 49 - Visonic Keypad

410-0024



Figure 50 -IEI Keypad

410-0014

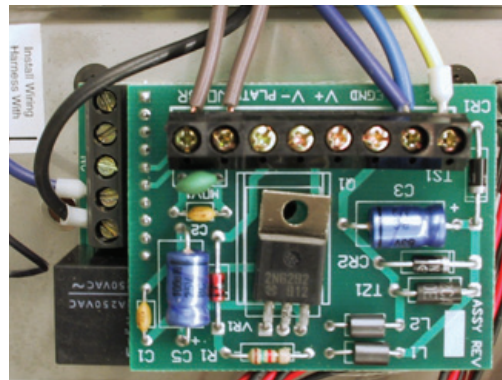
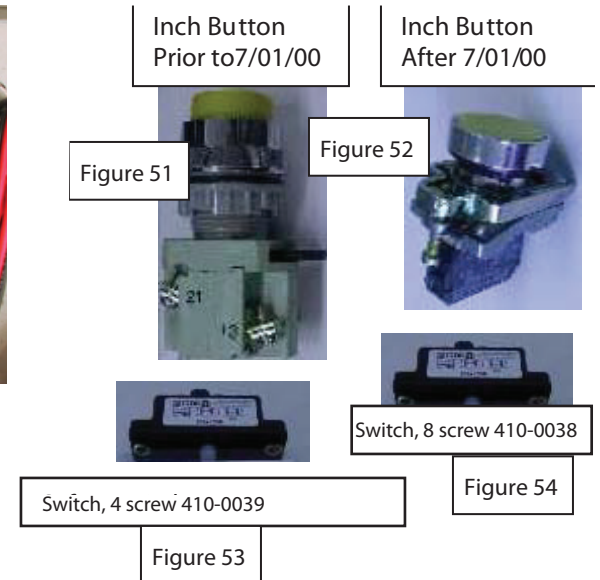

Figure 50 -IEI Keypad Filter Board- 410-0014



# UPDATE KITS

## Changes by Serial Number R6 - R7

Rear cutter idler sprocket.

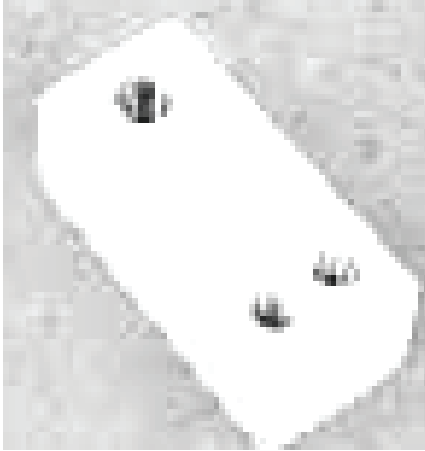

R7R rear cutter idler mount 8-44687.

Note on the R7R

Part # 111-0200 is replaced with part # 8-44687

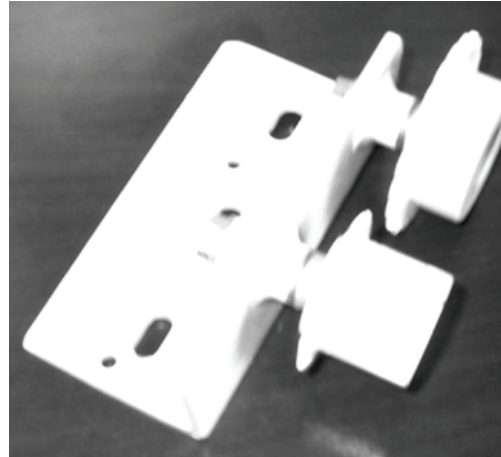

Figure 56

R5R & R6R rear cutter idler mounting angle 7-48058.

Note R7R no longer uses this bracket but has a bracket welded to the end panel of the machine, and uses part # 8-44687.

# UPDATE KITS

## Flap Disc Sharpener Update Kit (optional)

Flap discs replaced the double sanding discs as of 3/2002 All R5Rs, R6Rs and R7Rs can be retrofitted in the field with kit #111-0193.

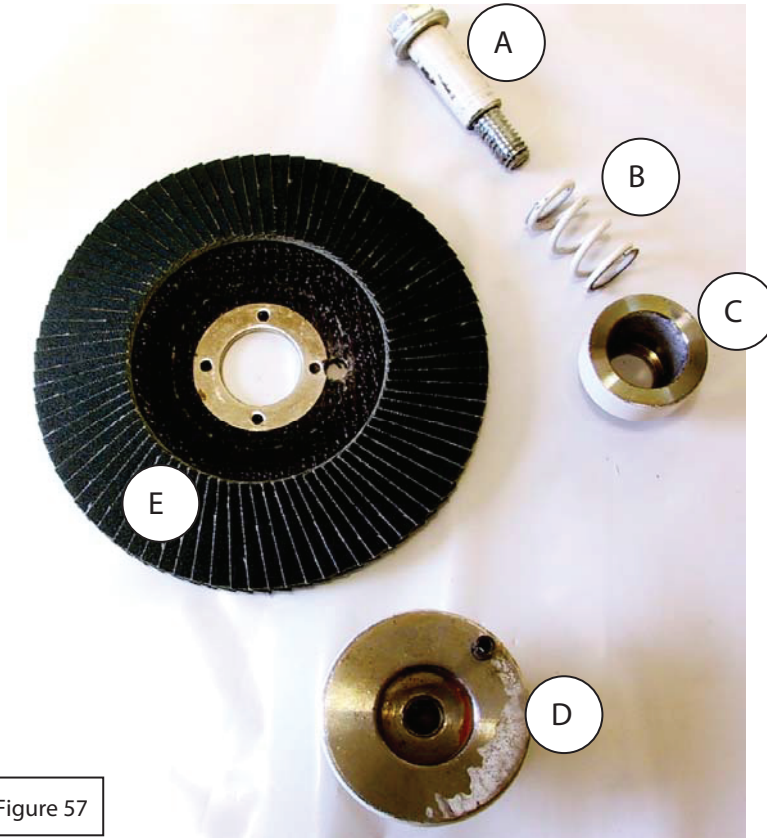

Figure 57

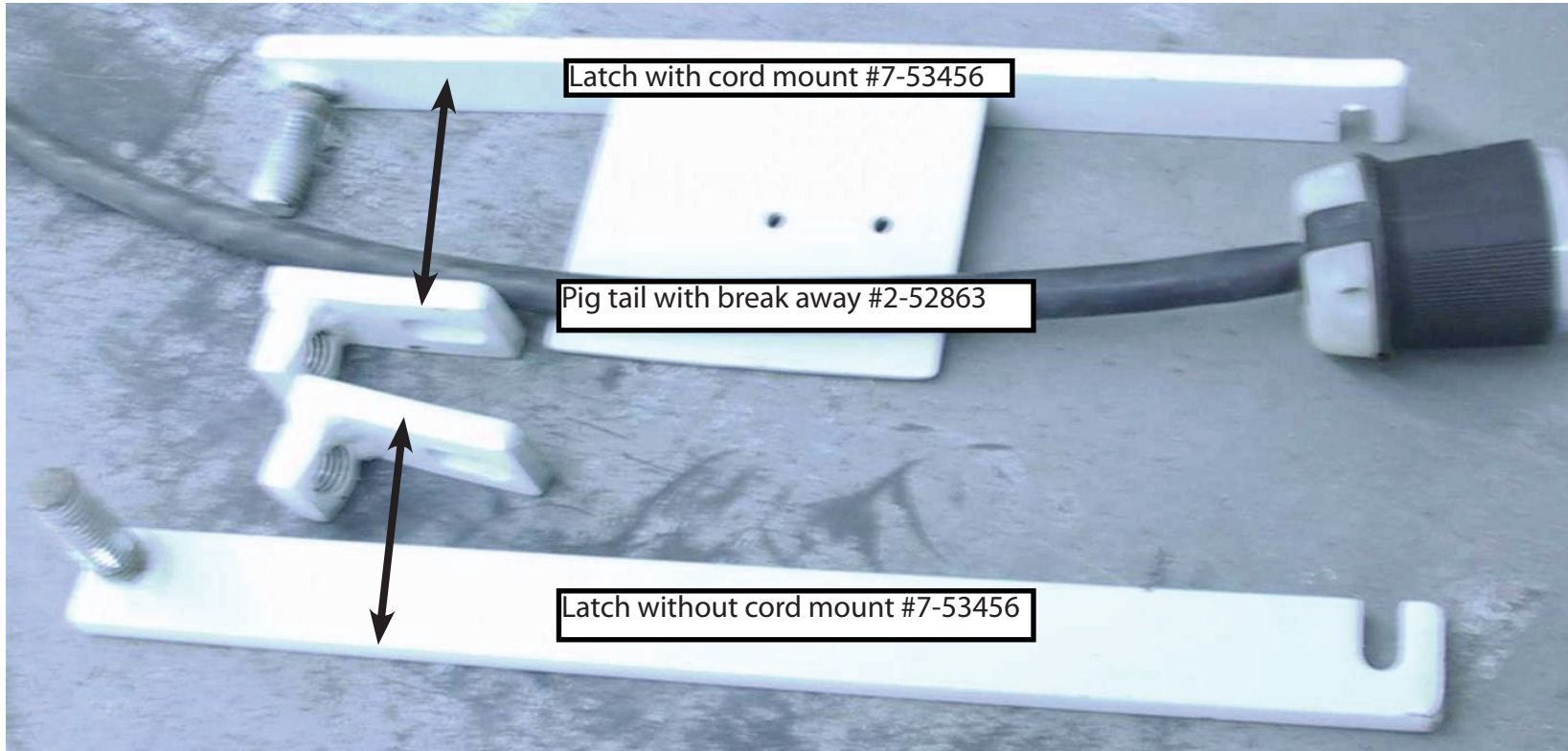

Figure 58

Key	Description	Part #
A.....	Sharpening disc bolt w/ washer and spacer.....	111-0190
B.....	Sharpening disc tension spring .....	119-0003
C.....	Sharpening disc centering cup.....	8-43420
D.....	Sharpening disc mandrel.....	8-43419
E.....	Sharpening disc .....	300-0047
F.....	Complete sharpening disc change over kit .....	8-53788

# UPDATE KITS

## R3 - R7 Latch Kit



Latch kit part #111-0246 (includes items below)

Rnr rear & frt latch w pig tail & mounts .....	111-0246
Receptacle twist plug 3ph 208v.....	408-0032
Plug breakaway p style (male).....	408-0038
Plug breakaway s style (female).....	408-0039

Machine latch mouting bracket - part #7-53456

When installing item #001-0423, latch-point on carousel:

When the threaded hole is required, tech will need to drill through the carousel post and attach the carriage bolt with a locking nut.

# MAINTENANCE

## Pinch Roller Centre Support

In the event that the RR unit has a problem with pulling the carpet from the carousel. The following support bracket can be installed underneath the center of bottom pinch roller. This support raises the center of the roller just slightly to increase the traction. To install the bracket:

1. Locate the flip down table center support bracket. (rear side of unit)
2. Remove the gripper tape (if there is one on the bottom pinch roller in line with bracket)
3. Slide clamp over tubing.
4. Insert plastic into clamp.
5. Insert bolt through the clamp and the plastic block. (rounded end against the roller)
6. Adjust the adjuster bolt to raise the center of the roller a maximum of 1/8",
7. Run machine to ensure it rolls correctly.
8. Do a test run on a roll of carpet to ensure that the problem is solved.

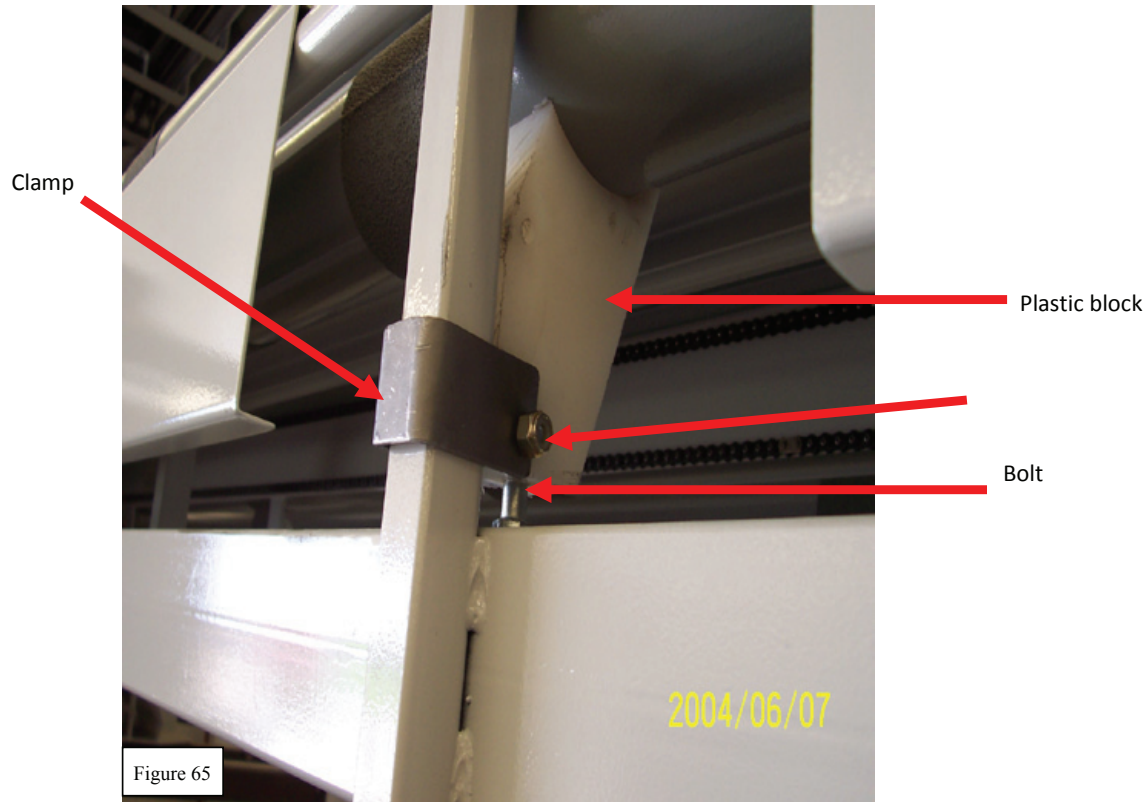

# MAINTENANCE

## Pinch Roller Centre Support (con't)

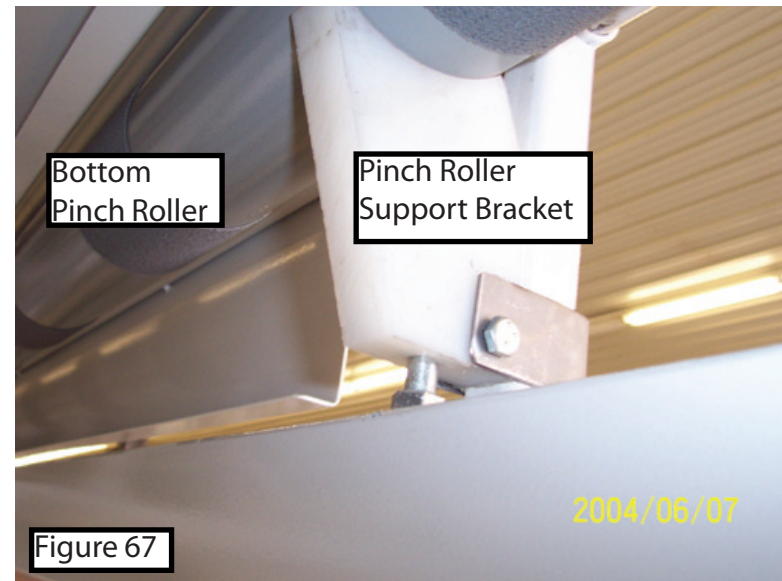
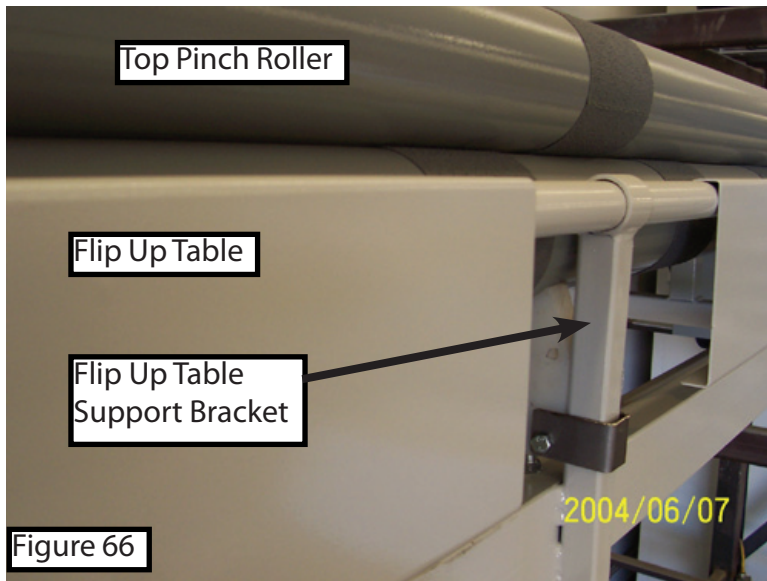



# WIRING SCHEMATIC

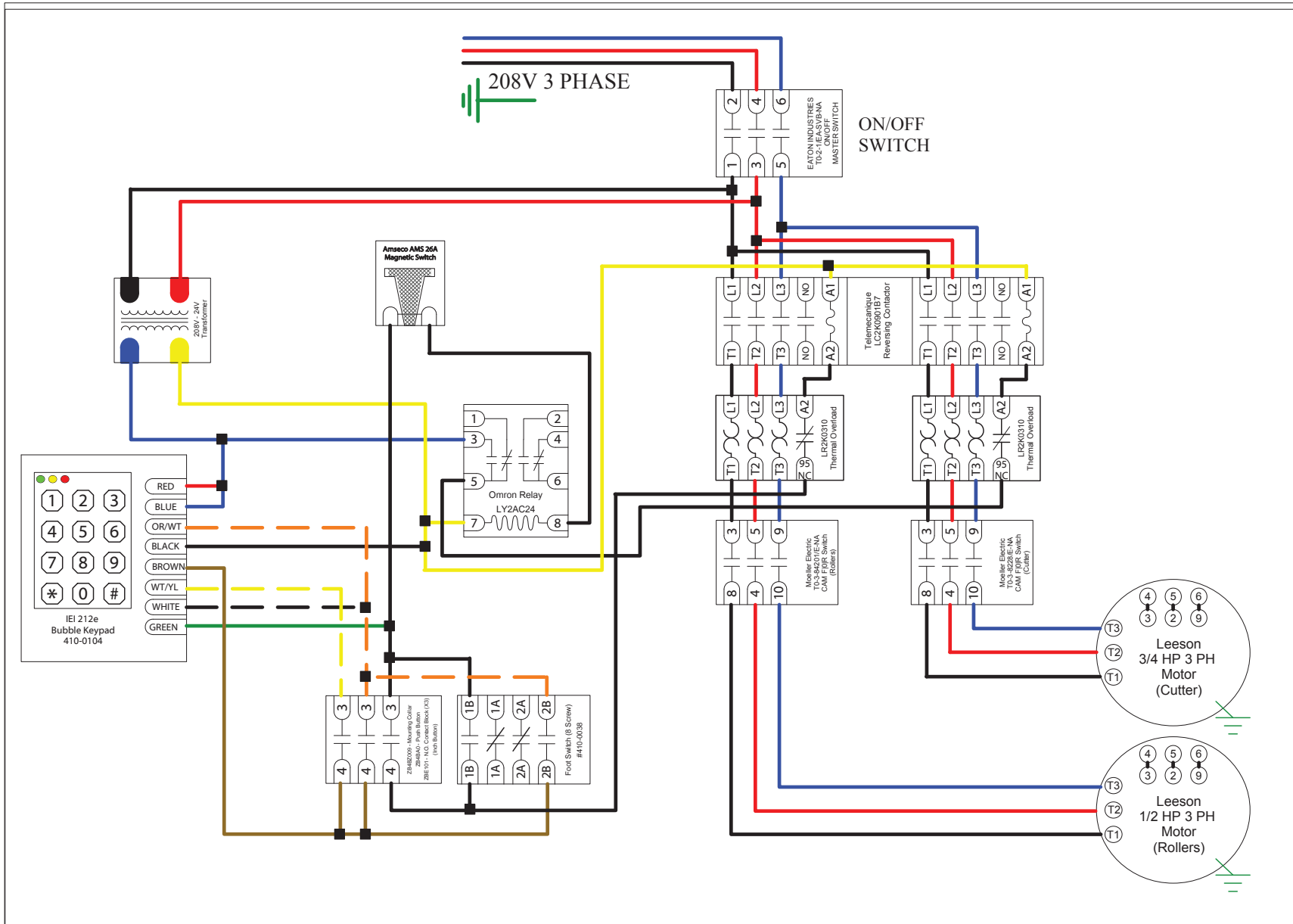

<p>Vidir Machine, Inc. Arborg, Manitoba 1-800-210-0141</p>	<p>Description: 3 phase rack and roll</p>	<p>Date: AUG 06/06</p>	<p>File name: three phase rack and roll_V2.tcw</p>	<p>Ratings: 60 Hz 208V 3 phase 15A</p>
--	---	----------------------------	--	--

# WIRING SCHEMATIC

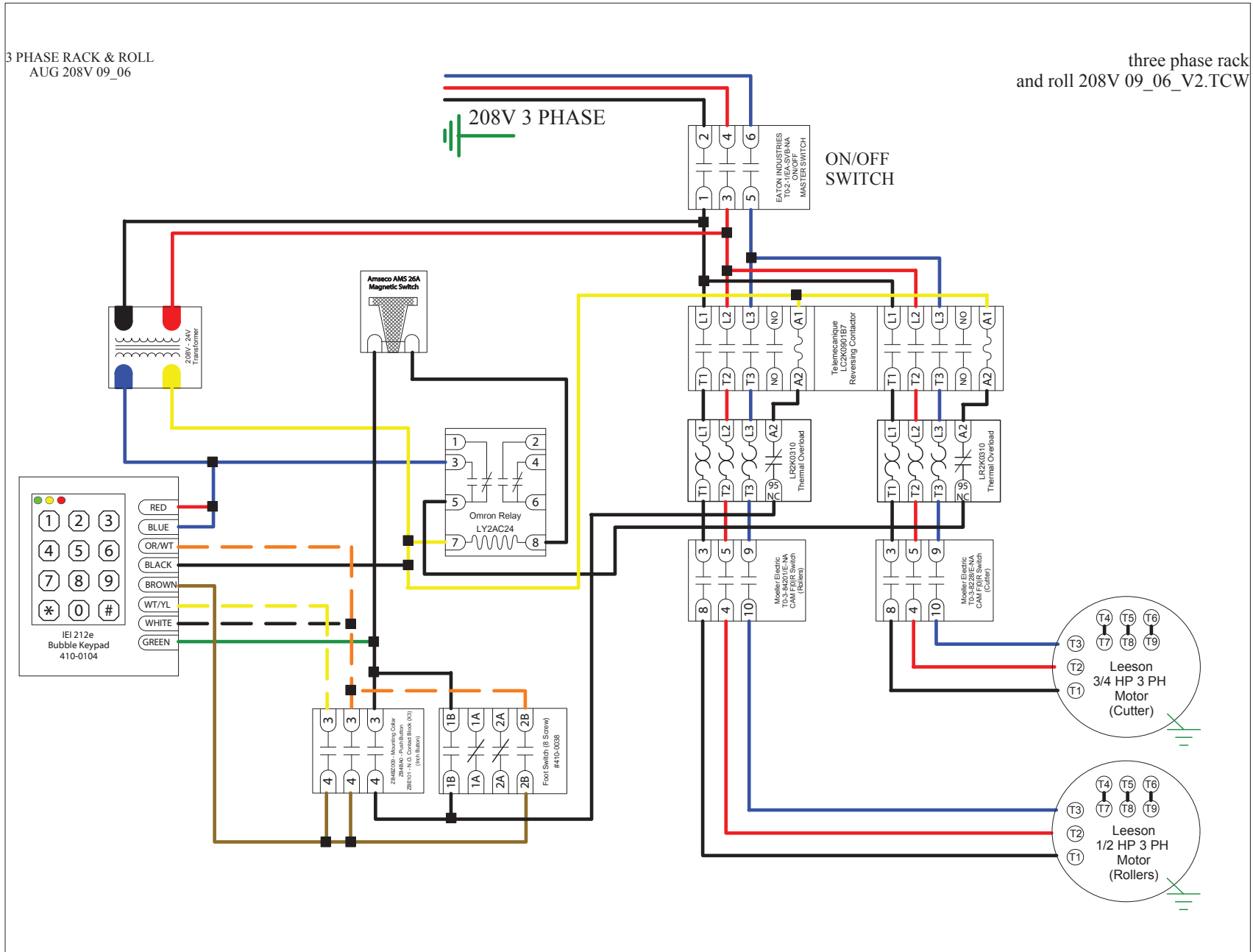

# WIRING SCHEMATIC

3 PHASE RACK & ROLL  
WITH CIRCULAR CUTTER  
(24 VOLT CONTROL)  
MARCH 16/98

208 three phase\_Visonic\_V2.tcw

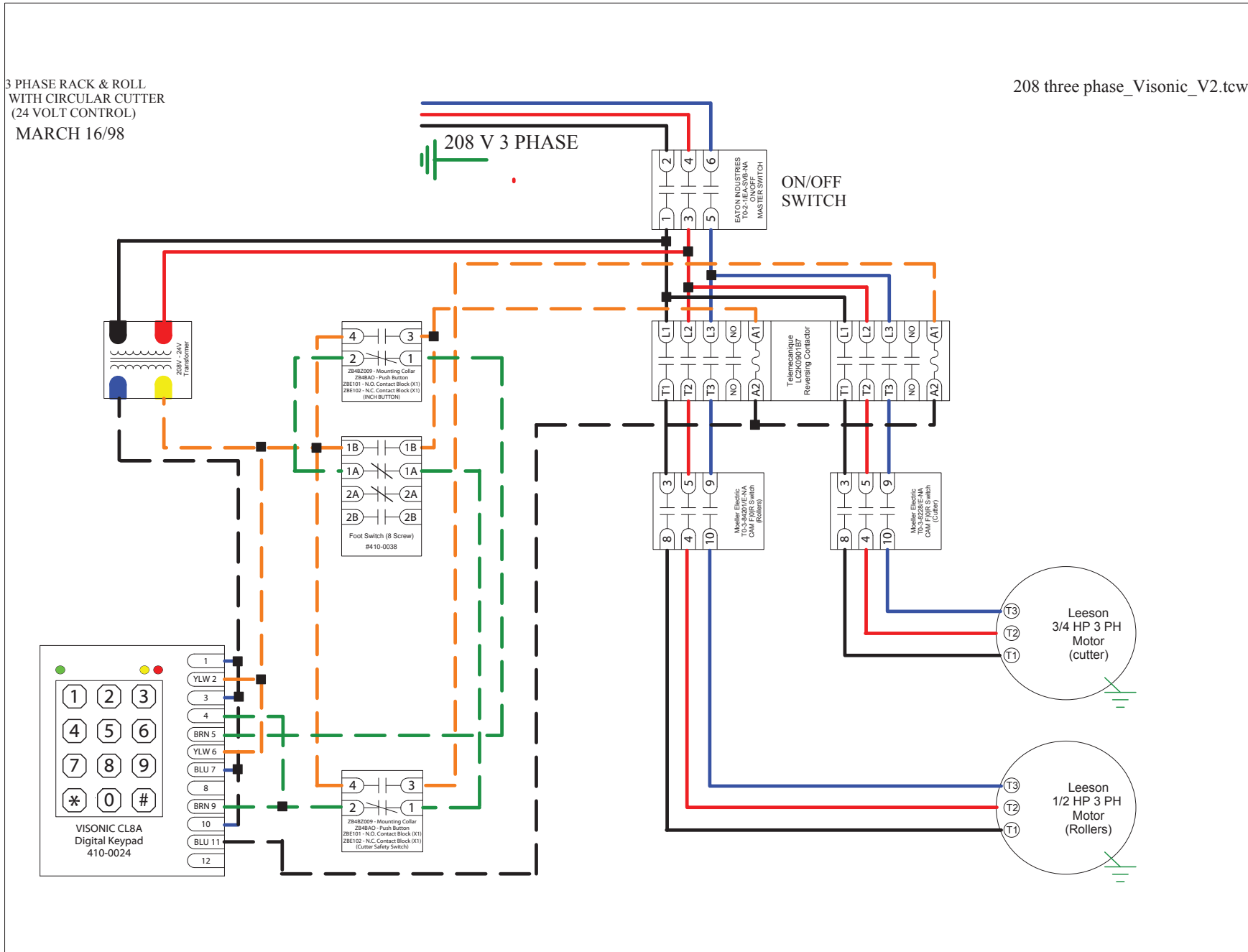

# WIRING SCHEMATIC

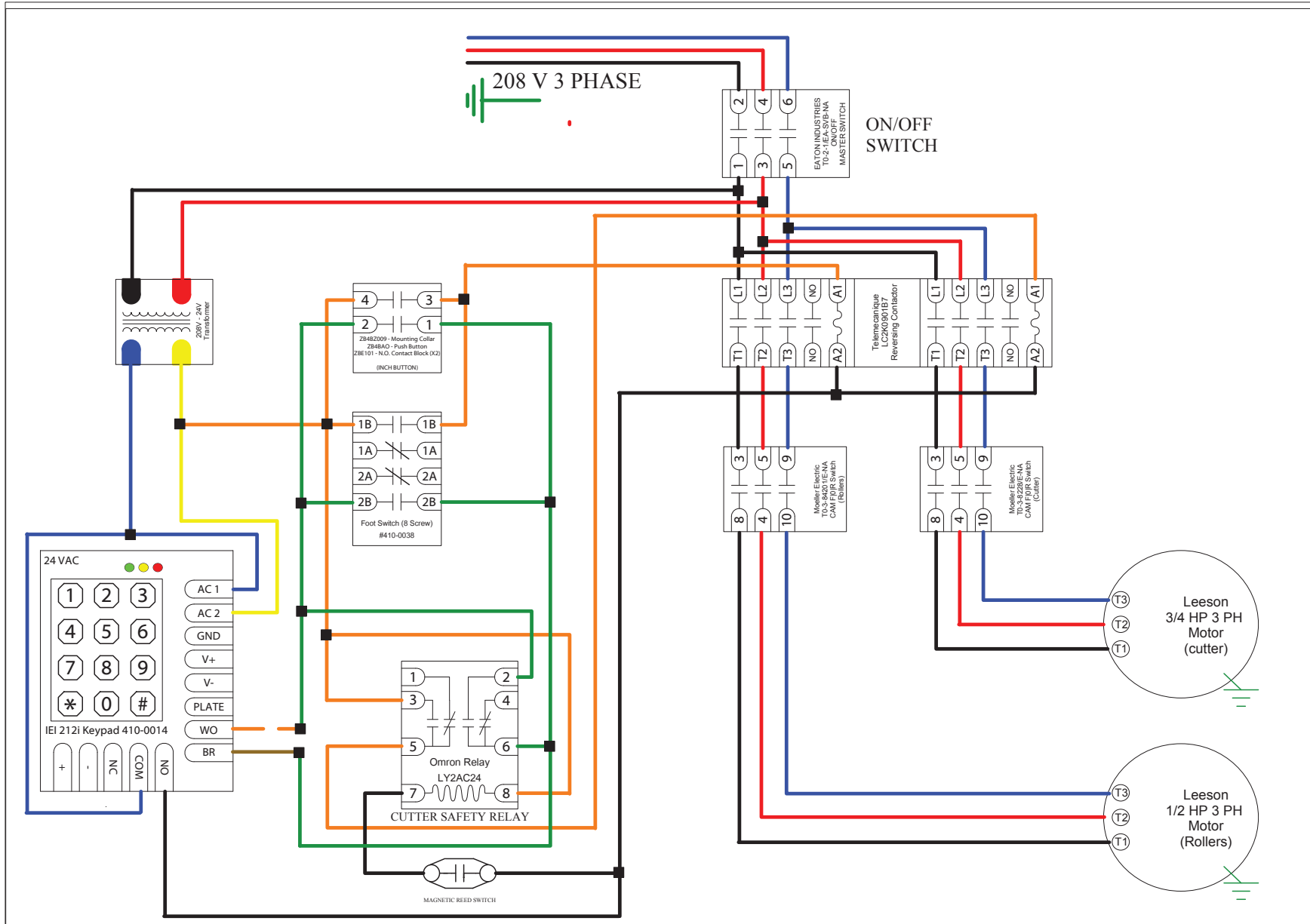

<p>Vidir Machine, Inc. Arborg, Manitoba 1-800-210-0141</p>	<p>Description: 3 PHASE RACK &amp; ROLL WITH CHAIN CUTTER (24 VOLT CONTROL)</p>	<p>Date: August 2000</p>	<p>File name: three phase rack and roll aug 0700_V2.tcw</p>	<p>Ratings: 60 Hz 208V 3 phase 15A</p>
--	---	--------------------------	---	--

# WIRING SCHEMATIC

3 PHASE RACK & ROLL  
VIDIR MACHINE LTD.  
1 (204)364-2442  
9-99  
VISONIC KEYPAD

three phase rack and roll 208V aug 0800.pdf

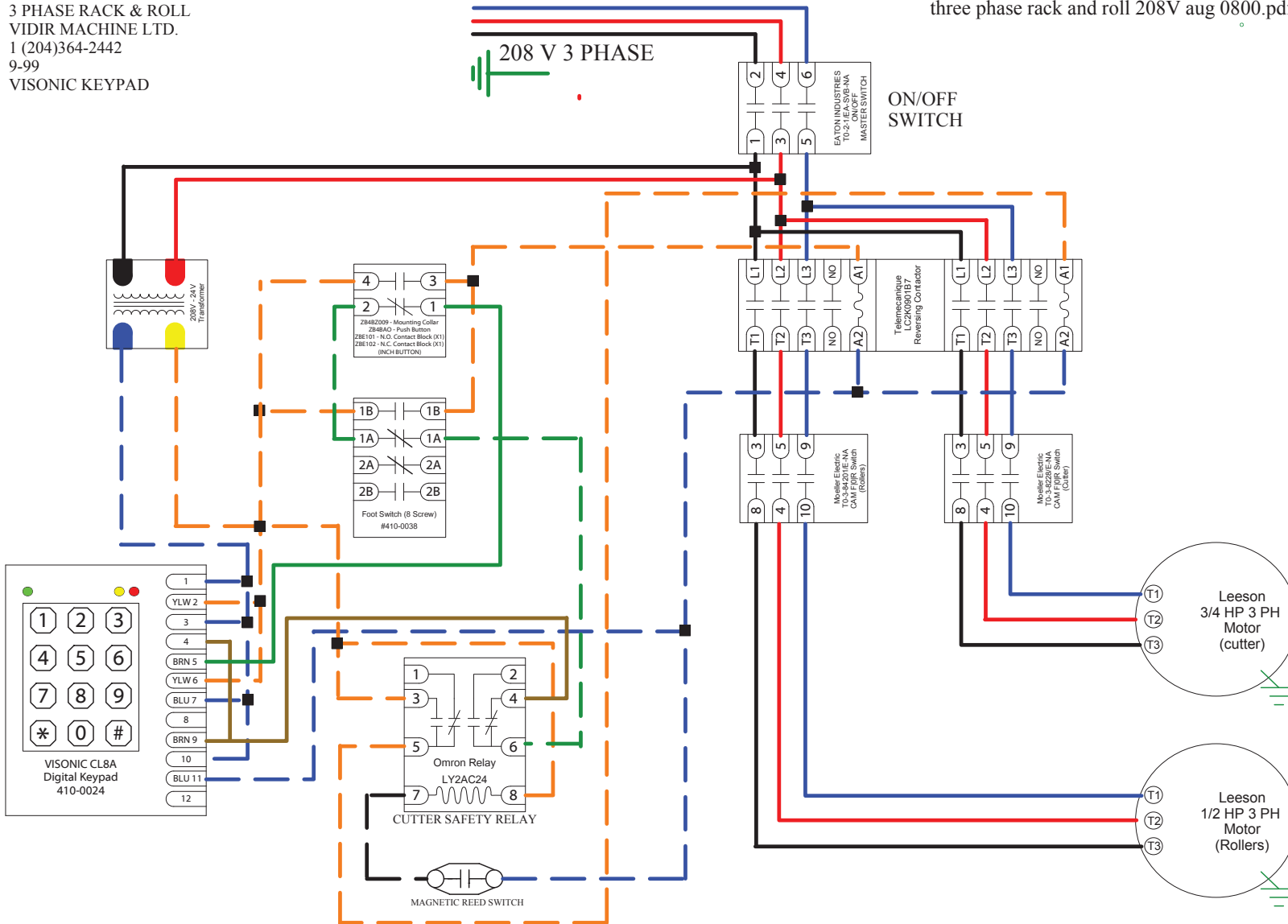

# WIRING SCHEMATIC

3 PHASE RACK & ROLL  
AUG 06\_06

three phase rack  
and roll aug 06\_06\_V1.tcw

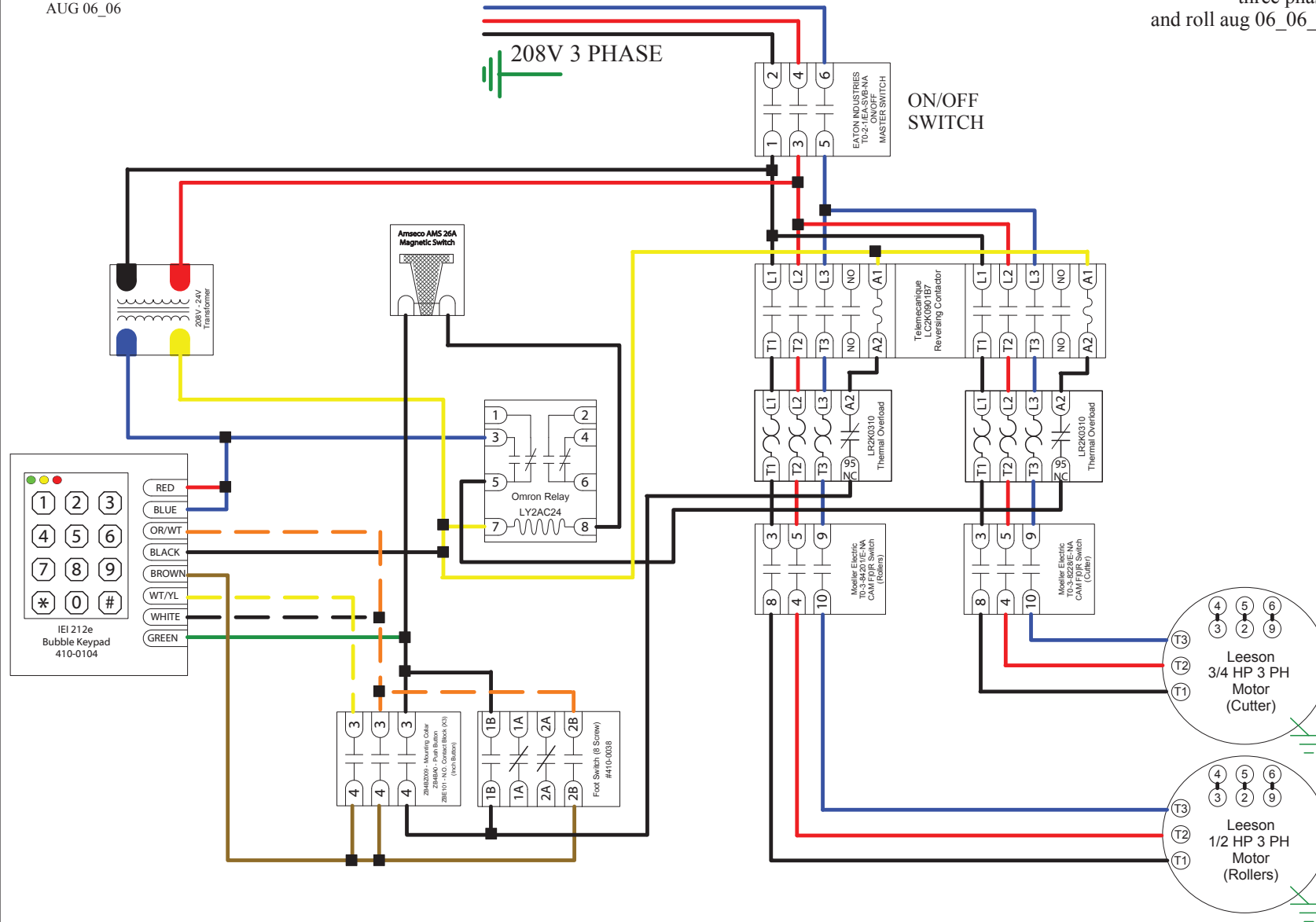

## California Type Evaluation Program Certificate of Approval for Linoleum/Carpet measuring Devices

Submitted by:  
Trumeter Company, Inc.,  
1020 North West 6 Street  
Deerfield Beach Florida 33442  
Tel: (954) 725 6699  
Fax: (954) 725 5599  
Toll free from anywhere in USA 800-537-2261  
Contact: Derek Rawden

### Standard Features and Options

- 3000 Series mechanical indicator (revolution counters) with an engraved cursor line
- Lever style zero reset
- Measures in feet and inches
- Six digit indication
- Counter can be driven from left or right side
- Equipped with an eighteen ratchet mechanical brake to prevent over spin
- Knurled aluminum measuring roller
- Rubber spring tension pressure roller

NOTE: This device was evaluated as special use and unclassified equipment (G-A3.) and complies with applicable paragraphs from the General, Fabric-Measuring and Wire- and Cordage-Measuring Devices Codes.

This device was evaluated under the California Type Evaluation Program (CTEP) and was found to comply with the applicable technical requirements of California Code of Regulations for "Weighing and measuring Devices"; Evaluation results and device characteristics necessary for inspection and use in commerce are on the following pages

Darrell A. Guensler  
Director, Division of Measurement Standards

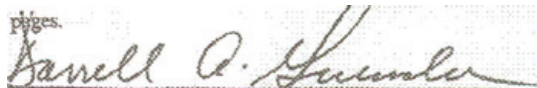
pages.  

Certificate Number: 4213-95 Page 2 of 2  
**Trumeter Company, Inc.**  
Linoleum/Carpet: Measuring Device Model:  
TRUMEASURE 3900

Application: For length measurement of linoleum and carpet. This device uses a Series 3000 mechanical register with an engraved cursor line.

Identification: The required identification is located at the roller end of the device.

Sealing: A wire security seal is affixed to the shaft of the measuring wheel, preventing its removal. Two wing bolts, located on the front of the device, must be loosened to raise the device and attach the security seal.

Operation: Care should be used when pulling the product through the measuring device to prevent slippage or measurement at an angle in relationship to the edge of the product. When pulling the product from the roll, the roll end must be even and not conical. Of an inaccurate measurement will result. It is suggested that a take-up roller used when measuring to assist in achieving a straight even pull.

1. Locate floor covering roll so the leading edge is level with the measuring machine and cutting bar. If not level, an inaccurate measurement will result. All floor coverings must be measured face side up.
2. Carefully pull the leading edge, bringing it between the upper rubber tension roller and the lower measuring wheel, until the leading edge lines up with the slot in the cutting bar.
3. Clamp the floor covering, using the two clamps located at the end of the cutting bar.
4. Set the counter to zero by pushing the reset lever once.
5. Release the clamps and pull the floor covering, and tape it to the take-up roller (if supplied).
6. Roll the floor covering at a constant speed until the desired length is indicated on the counter. If the desired length is exceeded, roll back the surplus length to the desired length. The counter subtracts measurement in the reverse direction.
7. Clamp the floor covering again using the same two clamps, before carefully making a cut along the cutting bar.

Test Conditions: The linoleum/carpet measuring device was tested at a field location. The emphasis on the evaluation was on the design, marking and performance. The Fabric-Measuring Device tolerances were applied to the device under test and a certified steel tape was used to verify the lengths of the various materials used for the evaluation. Several accuracy, slippage, and repeatability tests were conducted, Similar tests were repeated two months later. The results of the evaluation indicate this device complies with applicable requirements,

Type Evaluation Criteria Used: California Code of Regulations, 1995 Edition

Tested By: D. Reiswig (CA), C. Nelson (CA)  
October 1995

P. No. 016708-C1



## RE-ORDERING DETAILS

To order further machines, please quote model number : 1) Model 3900 (metric), or 3905-1 (feet & inches), or 3905-2 (yards & 1/8ths), fitted with front viewing totalizing counter, as approved under the State of California General, Fabric Measuring and Wire and Cordage Measuring Devices as a device for linoleum/carpet measuring

OR

2) Fitted with Encoder, Model 3910 (metric) or 3915 (imperial). A suitable electronic Printing Counter Model 8320 is available. See separate data sheet.

OR

3) Fitted with mechanical Printing Counter, Model 3920 (metric), or 3925-1 (feet & Inches), or 3925-2 (yards & 1/8ths).

## CALIBRATION SERVICES

In the U.K., Trumeter provide sophisticated on-site or factory Calibration Services, together with formal Certificates of Calibration inspections and tests are performed with equipment that is traceable and calibrated to national standards. All procedures comply with ISO 9002.

In the USA, Trumeter provide sophisticated factory calibration services together with formal certificates of calibration Inspections and tests are performed with equipment which is backed by 60 years worldwide experience traceable to US Federal Standards.

Please contact your nearest Service Centre for advice and to arrange appointments. In countries outside the UK or USA, please contact your nearest distributor.

## Features

Precision engineered by Trumeter to the highest standards of accuracy and durability-backed by 60 years worldwide experience of length measurement

Knurled aluminum measuring roller in the base-sealed and stamped to prevent removal by unauthorized personnel.

Adjustable spring loaded pressure roller in the top arm – designed to prevent unauthorized adjustment after initial setting.

Simple, push the lever resetting to zero or disabled for overall totalizing only- up to 99,999 feet 11 inches or 9999,99 metrics/cms – with red on white numerals for inches or centimetres.

Integral 18 ratchet mechanical brake wheel to prevent overspin at the end of a piece; releases automatically when a further piece is passed through the rollers.

Fine red cursor line through centre of counter window, inch/centimetre wheel with a cursor line through every number and with red figures on a white background makes for easy and accurate reading of measurement.

## SERVICE FACILITIES

Annual service contracts are available either on site (UK), or on a return to factory basis (UK & USA).

Trumeter Company, Inc.,  
1020 North West 6 Street  
Deerfield Beach Florida 33442  
Tel: (954) 725 6699  
Fax: (954) 725 5599  
Toll free from anywhere in USA 800-537-2261  
Email: sales.usa@trumeter.com

Trumeter Company, Inc.,  
Trumeter House  
Hornby Street  
Bury  
Lancs  
England BL9 5BW  
Tel: +44 161 705 4317  
Email: sales.uk@trumeter.com

# OPERATING INSTRUCTIONS

## **THE** **TRUMEASURE** **3900**

### THE LENGTH MEASURING MACHINE APPROVED FOR RETAIL USE

- 1) Locate floor covering roll so that the leading edge is level with the measuring machine and cutting bar, If not level, incorrect measurement will result - -see illustration. All floor covering must be measured face side upwards.
- 2) Carefully pull the leading edge towards you, bringing it between the upper, rubber tension roller and the lower, measuring wheel, until the leading edge lines up with the slot in the cutting bar
- 3) Clamp down the floor covering, using the two clamps located at each end of the cutting bar.
- 4) Set the counter to zero by pushing the reset lever once.
- 5) Release the clamps and pull the floor covering towards you, in order to tape it to the roll-up roller, if required.
- 6) Roll off the floor covering at a constant speed, keeping the counter in sight, until required length is indicated on the counter. If you roll past the required length, simply roll back the surplus length to the required length, as the counter also subtracts.
- 7) Clamp down the floor covering again, using the same two clamps, before carefully making your cut along the cutting bar.

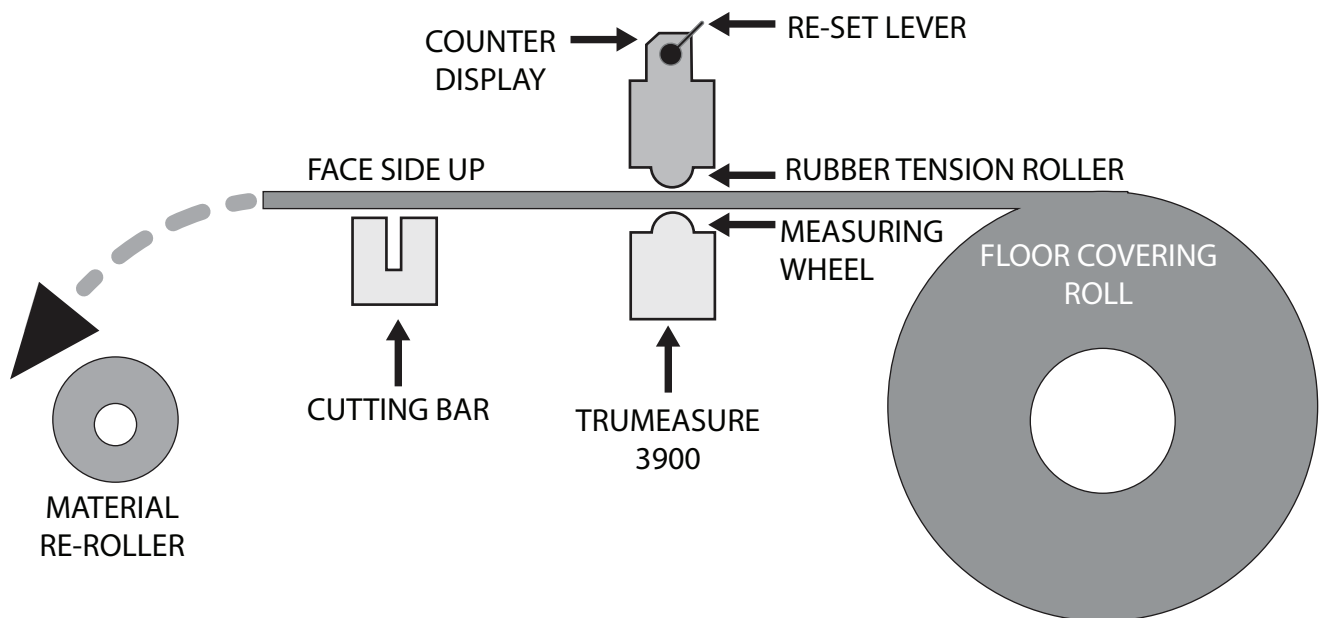

# Rack 'N' Roll Preventative Maintenance Checklist

Company	City	Province	Date of Service:
Store No.	Serial No.	Model/Type	
Service Company:		Store Signoff:(Print)	
Service Technician (Print):		Store Title:	
Service Tech Signature:		Store Signature:	

**Preventative Maintenance is Recommended Every 100 hours or 12 months.** The inspection of all hooks, bolts, pins, mounting hardware, chains and the overall condition of these components are critical to ensure machine safety, and integrity of the preventative maintenance process. Initialling each line as indicated below confirms these items have been thoroughly inspected for defects.

✓ Indicates item is inspected and in good condition - ✗ Indicates item requires additional service	Service	Initials
Run cutter from end to end, listen for any strange sounds (must park under protective covers front & rear). Fig 1.		
Check blade sharpener for proper operation. Fig 2.		
Change cutter blades if necessary (chipped or worn down).		
Check cutter chain tension (must be taut, must not be rubbing on the frame).		
Check condition and tension of the cutter drive belt.		
Checked condition and tension of the roller drive belt.		
Ensure that bearing locking collars are tight. Fig 3.		
Check tension on roller drive chain. Fig 3.		
Retrofit cutter hold-down bar pivot bolt. First PM only.		
Inspect cutter hold-down bar pivot and latch operation (following PMs) .		
Check pinch roller latch and pivot points for proper operation.		
Check key-pad for proper operation.		
Check counter calibration (with tape measure).		
Check counter wheel for free rotation.		
Check counter hold-down weight for free rotation and free movement.		
Foot cable operates properly.		
Inspect caster wheels for wear, and alignment.		
Grease caster wheels and removed fibers.		
Check overhead power cord, festoon cord for wear, clearance and proper travel. Fig 4.		

### Recommended Components

Qty	Description	Part #	Qty	Description	Part #	Qty	Description	Part #
24	Grip tape	117-0005	1	Switch stem	410-0052	1	Flap disc	300-0047
1	Pivot bolt kit	111-0293	1	Switch knob	410-0026			
1	Sharpening disc	300-0046	1	blade	103-0004			

**Conclusion:** This unit has been inspected and serviced for safe operation and is operating as intended by the manufacturer.

Comments and Parts Used (If any): \_\_\_\_\_

\_\_\_\_\_

\_\_\_\_\_

\_\_\_\_\_

\_\_\_\_\_

# Rack n Roll Preventative Maintenance Checklist

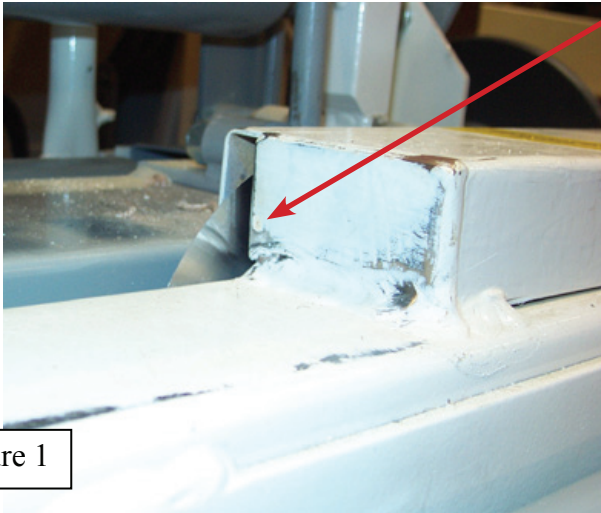

Blade must rest fully under the cover. If not loosen the cutter clutch just slightly. If this fails, install a cutter blade cover extension.

**Caution: Cutter blade is sharp. Hand injury may occur.**

Figure 1

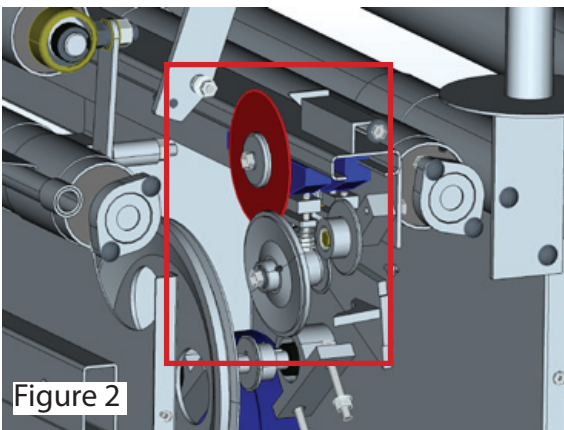

Ensure the blade engages the sharpener disc aggressively enough to sharpen the blade.

Figure 2

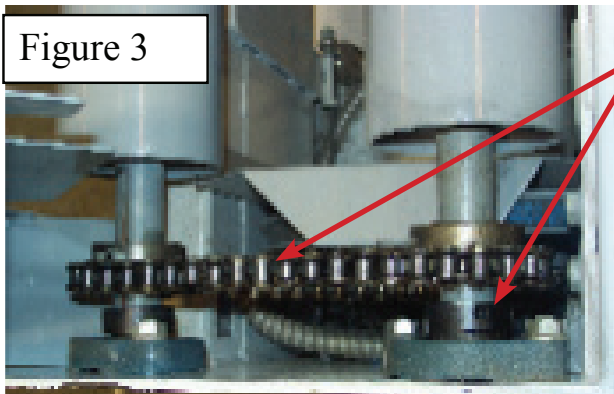

Check chain tension. To tighten slide, T tightner down, nuts located inside the electrical box. Ensure locking collars are tight.

Figure 3

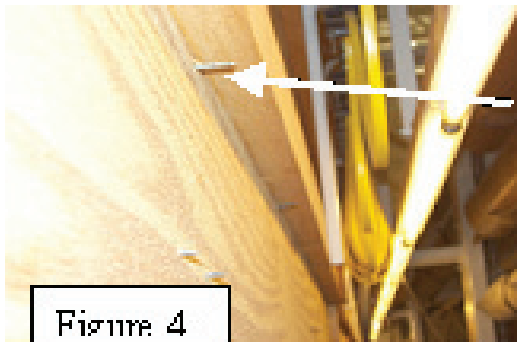

Check that there are no screws sticking into the path way of the cord.

Ensure wire carrier trolleys are in good condition. Ensure that festoon cord is not nicked or cut or worn through at any place.

Figure 4

# **WARRANTY & LIABILITY**

## **Vidir Machine Inc. Warranty Agreement and Limitation of Liability**

1. Vidir Machine Inc. ("Vidir") warrants solely that the equipment shall be free from any defect due to faulty workmanship or material deficiency at the time of delivery to the buyer thereof (the "Buyer") and for a period of one year therefrom.
2. All work except minor repairs or adjustments to the equipment furnished on an emergency basis, will be performed during regular working hours. If the Buyer requests that repair work be performed outside of regular working hours, it is the responsibility of the Buyer to pay the difference between regular and premium labour rates at the then standard hourly billing rate.
3. This warranty shall be voided by any modifications to the equipment or any use of the equipment for any purpose other than that for which it was specifically intended.
4. This warranty is the only warranty made by Vidir. The Buyer hereby expressly waives any obligations or liability, including liability for loss or damages due directly or indirectly, any obligations including, without limitation, loss of use, revenue, or profit, shipping and handling, and injury to person or property.
5. It is the responsibility of Buyer to know, understand and comply with the work and safety laws and regulations in effect and governing Buyer's use of the equipment. To the extent governing law requires inspections, records keeping and/or after-purchase modifications to the equipment, it is the responsibility of the Buyer to arrange for and comply with such requirements and any associated costs are the sole responsibility of the Buyer. Vidir assumes no responsibility or liability for Buyer's performance under or compliance with such laws and regulations.
6. If the equipment is found by the Buyer to be defective, the Buyer must notify Vidir within a period of 30 days of discovery of the defect.
7. The Buyer is expected to provide access to all equipment covered by this warranty. Vidir shall not be responsible for any expense incurred in removing, replacing, or refinishing any part of the building structure necessary for the performance of Vidir's obligations under this warranty.
8. In the event that any alterations, additions, adjustments or repairs are made by others without Vidir's prior written consent, Vidir may, at its option, immediately terminate this warranty by providing written notice to the Buyer.
9. In the event Vidir is required to make emergency calls, repairs and/or replacements under this warranty occasioned by the Buyer or any user's negligence, improper operation or misuse of the equipment or by fire, explosion, flooding, the elements, strikes, labour troubles, vandalism, riots or civil commotion, or by any cause beyond Vidir's control. The Buyer shall reimburse Vidir for such emergency calls, repairs and/or replacements in accordance with the then current rates for such services.
10. Vidir's liability for injury to persons or property shall, in any event, be limited to that caused directly by its negligence. Vidir shall not be liable, however, on any account, for any damage or loss to the Buyer or its dealers, representatives, affiliates or agents resulting from business interruption, inconvenience, loss of profits, or special or, indirect or consequential damage. Vidir shall not be deemed to guarantee or warrant the continuing operation or operating efficiency of the equipment covered, nor shall Vidir be liable for any breakdowns thereof or for any damage to any other property of the Buyer not covered by this warranty but resulting from any breakdowns in or operating mishaps of the equipment covered.
11. Should any payment due by the Buyer become thirty days or more delinquent, Vidir may terminate this warranty by written notice, and all moneys owed Vidir shall be immediately payable on demand.
12. This warranty is not transferable or assignable by the Buyer.
13. Vidir reserves the right to determine, in its sole and absolute discretion the best means and methods to be employed for any corrective or repair work deemed necessary by Vidir pursuant to this warranty.