

Carpet Carousel Advanced Troubleshooting Guide

COMPACT POWER
EQUIPMENT SERVICES

We Deliver Extraordinary Service.

Carpet Carousel

Advanced Troubleshooting Guide

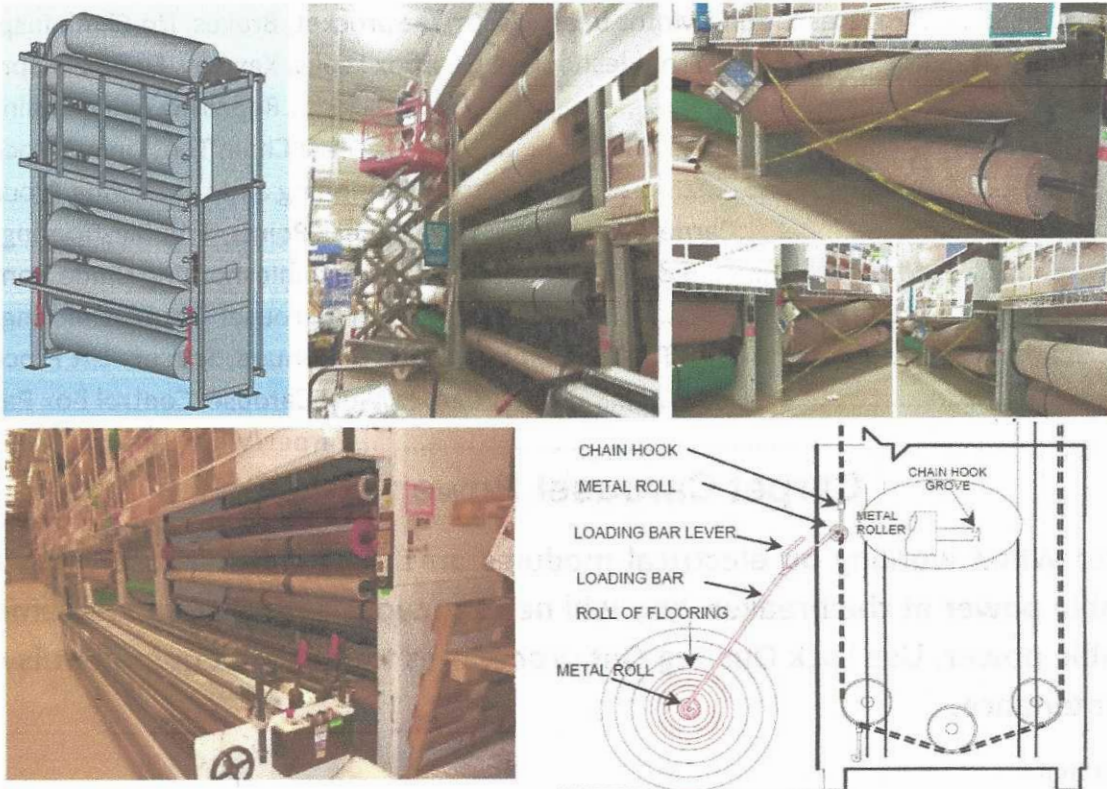

Note: Always wear protective gear that fits the situation. Do NOT wear loose clothing while operating this equipment. Do not reach across machinery. Clothing can become entangled and cause serious injury.

Carpet Carousel Advanced Troubleshooting Guide

Table of Contents

1.....	Cover
2.....	Table of Contents
3.....	SOP: Safety, Troubleshooting the Overload
4.....	Troubleshooting the E-stop assembly
5.....	Troubleshooting the Transformer Primary and Secondary Coils
6.....	Troubleshooting and Programming the Visonic CL-4 Keypad
7.....	Troubleshooting, Programming the Visonic CL-8A Keypad
8.....	Troubleshooting and Programming the HTC Keypad
9.....	Troubleshooting and Programming the IEI 212i Keypad
10.....	Troubleshooting and Programming the Intertex Keypad
11.....	Troubleshooting the Magnetic Contactor and Motor
12.....	Troubleshooting the Motor Windings
13.....	Troubleshooting Motor bearings, Drive Sprocket, Brakes, No Climb Inspection
14.....	Troubleshooting Gearbox Leaks, Keyway, Debris in Sprockets
15.....	Repairing Drive Chain Issues
16.....	Drive Chain Tensioning Procedures
17.....	Load Chain Tensioning and Lubricating Procedures
18.....	Carpet/Vinyl Carousel PM Check Points, Troubleshooting Guide
19.....	J & D Associates Carousel Troubleshooting Guide Continued
20.....	VIDIR Carousel Troubleshooting Guide
21.....	VIDIR Troubleshooting Guide Continued, Scissors Lift Procedures
22.....	Carpet/Vinyl Carousel Control Box Parts List
23.....	Carpet/Vinyl Carousel Schematics

Carpet Carousel Power Shut Off

Note: When working on electrical modules on the Carpet Carousel, be sure to disable power at the breaker. You will need to work with store management to disable power. Use Lock Out Tag Out procedures to indicate equipment is under maintenance.

Disclaimer:

These product training resources are not all inclusive and should not be considered a substitute for reading and following the Manufacturer's operations manual. This guide is offered as information and guidance only. Users of the information contained in this training manual use that information at their own risk. Compact Power does not accept any liability for any loss, costs, damage or injury which may be sustained by any person in reliance upon information contained in this manual. The information provided is not provided on behalf of any manufacturer.

Carpet Carousel Advanced Troubleshooting Guide

!!! It is important to read all Manufacturer Safety Warnings before operating machinery. !!!

Operate machinery fully to determine the extent of problems experienced unless it has been indicated by store staff that it would be dangerous to do so. There may be a combination of issues present. Focus on one problem at a time to discover what you did that caused the problem to go away. Problems can be categorized as **Mechanical** or **Electrical** on the **Carpet Carousel**. Photograph close-up and full view shots of the machine when you determine abuse or accident for the cause of the problems. You will need to upload these photos in your service report and Field One to update equipment condition and status.

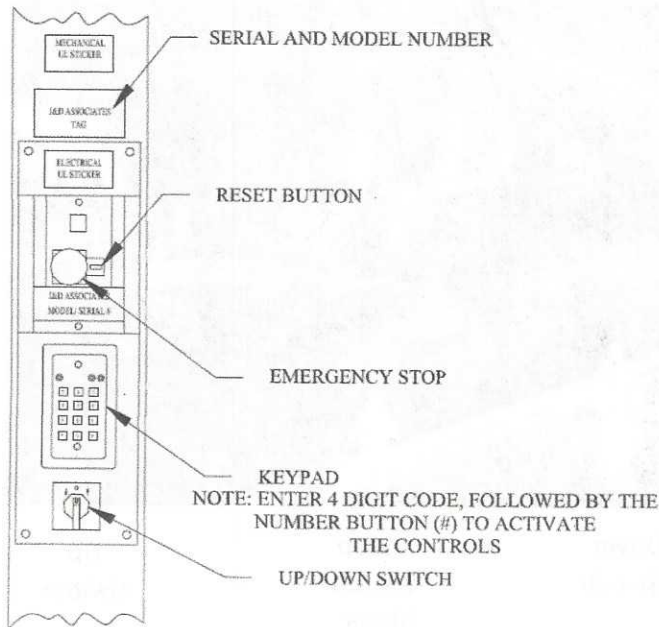

Typical Control Panel

Standard Operating Procedure:

Most Carousels have a keypad, E-stop, Up/Down buttons for controlling the motor when moving product rolls up or down. Some older machines are always "on" and have no keypad. The Diagram to the left is a J&D Associates Carousel Setup.

To operate:

- 1. Safety Check.** Check under and around the carousel to make sure the machine has clearance to move. Check for missing or damaged safety covers.
- 2. Press the E-stop button to test.** The power should be off not allowing the carousel to operate. Press the reset button (on AEP, Schneider or Telemechanique

Overloads) and the power should be restored allowing the keypad to operate again. If the

Overload with cover removed for testing

Estop button should disconnect power when pressed



Incoming Line Voltage 3 Phase
Test L1 to L2, L2 to L3, L1 to L3
to check quality of incoming power. You will find most applications have 208VAC incoming power.

Reset Button should reset Overload when pressed

Outgoing Load Voltage 3 Phase
Test T1 to T2, T2 to T3, T1 to T3
to check quality of outgoing power

Carpet Carousel Advanced Troubleshooting Guide

E-stop is not operating properly, troubleshoot the overload switch and replace if necessary. Be sure the power to the carousel is disabled before replacing components. **NOTE: incoming three phase power is present at the overload switch even if you press the E-Stop button.** Incoming LINE voltage comes directly to the overload/Estop and then onto the other electrical control components such as transformer, keypad, contactor, motor starter, then motor.

There is another style of E-stop and switch setup shown to the right. These are made up of Normally open and Normally closed switch stacks. Notice the identifying information printed on each switch. Individual components will need to be ordered separately when replacing these switches if you test

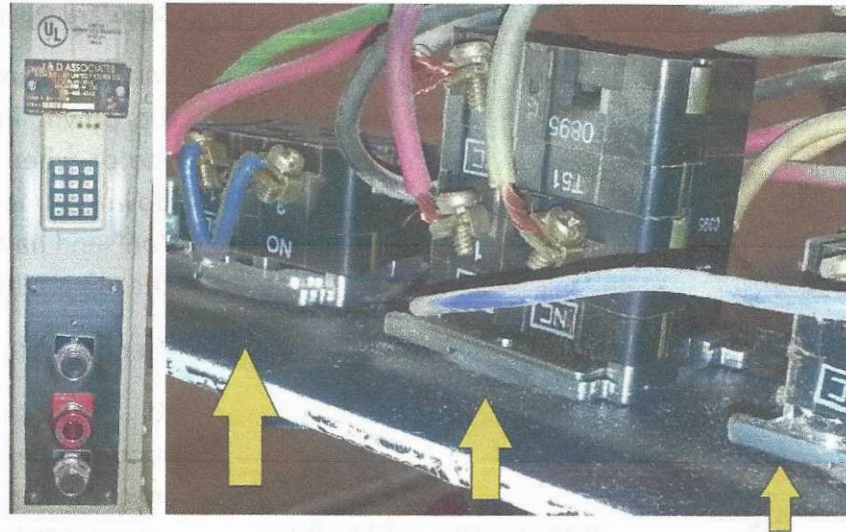

Older Style Switch Setup

Down Switch

E-stop Switch Stack

Up Switch

and discover they no longer operate. These will often have mechanical switch failures, such as cracks in the plastic workings. Electrical switch contacts can become pitted causing poor contact or welded shut causing power to flow in the off position. When troubleshooting these types of switches be sure to isolate this circuit from power and test each switch in their normal state (normally open or normally closed) using your ohms meter. The switches shown in the photo are common Eaton/Cutler-Hammer 10250T3, 10250T51 and 10250TC1301.

- 3. Testing the Transformer.** The carousel transformer steps down the incoming voltage to power the control circuitry, such as the Keypad, contactors, switches, and timer relay. The first step in testing the transformer is to check the integrity of the primary and secondary coils. Draw a diagram or take a photo of the wiring block where the transformer is connected. With power shut off to the control panel, remove the wires of the transformer from the wiring block.

Carpet Carousel Advanced Troubleshooting Guide

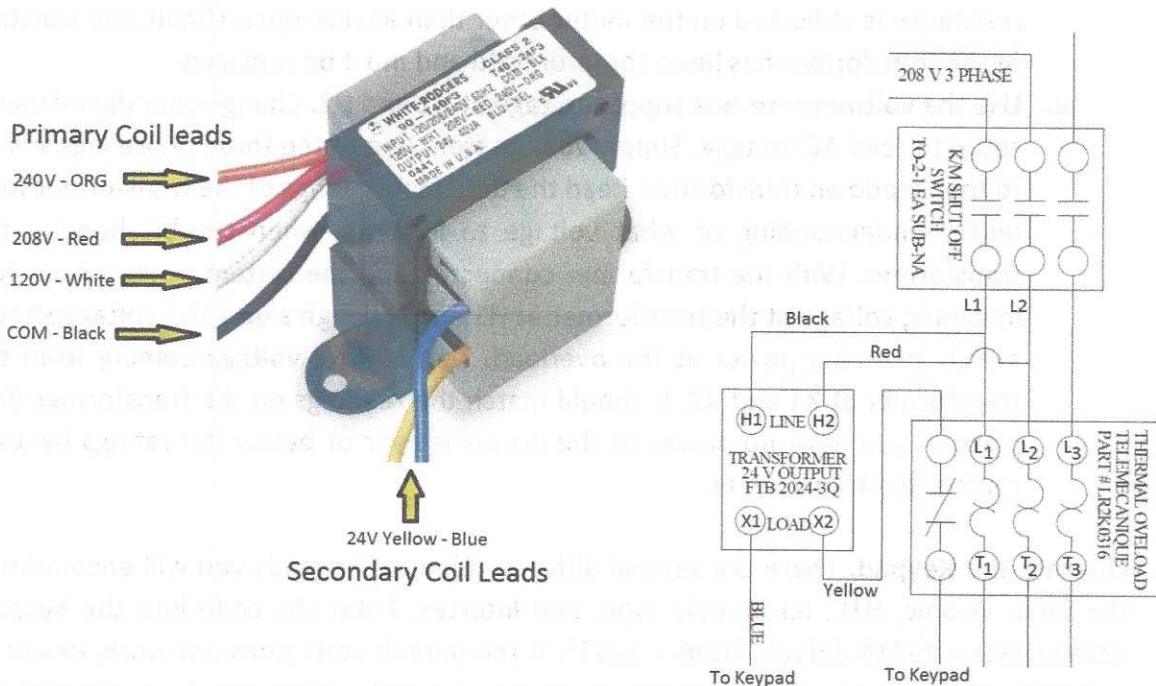

- Verify Primary and Secondary Coils are not shorted to the transformer frame:** Prepare your digital multi-meter to test Ohms. Touch the black lead to the metal frame of the transformer. Touch the red lead to the transformer's terminals in the following order: H1, H2, X1 and then X2. In the case of the primary coil having several choices for varying voltages, touch the red lead to each wire (Black, White, Red, Orange.) The meter should read infinite ohms or wide open. Infinite ohms on a digital meter will be identified as a blank screen or a wide open will have the word "Open" displayed. Different digital meters may have various screens. If the meter registers any level of resistance, there is an internal problem with the windings. The copper coils may be shorted to the metal frame of the transformer. The transformer must be replaced.
- Check the continuity of each separate coil using the ohmmeter.** Touch the black lead to H1 and the red lead to H2, or black lead to common and red lead to each primary wire. The meter should give a resistance reading. Generally, it should read in the range of 3 to 100 ohms, depending on the style and type of transformer.
- Perform the continuity test to the X1 and X2 terminals.** You should receive the same results. If the meter reads infinite ohms or a wide open when checking between the terminals of the same coil, the wires are broken. Replace the transformer.
- Use the ohmmeter to test the transformer's isolation circuit.** Touch the red lead to H1 and the black lead to X1. The meter should read infinite ohms or a wide-open circuit. Perform the same test, but to H2 and X2 respectively. If any

Carpet Carousel Advanced Troubleshooting Guide

resistance is indicated on the meter other than a wide-open circuit, the isolation of the transformer has been compromised and must be replaced.

- e. **Use the voltmeter to test supply voltage at H1 and H2.** Change your digital meter setup to read AC Voltage. Supply voltage from two of the three phase legs will go to the stepdown transformer. Read the data plate ratings of the transformer for a better understanding of what voltage to look for when troubleshooting the transformer. With the transformer connected and the system powered up, test incoming voltage at the transformer at H1 and H2 (high side.) The voltage should match incoming power at the overload. Test control voltage coming from the transformer at X1 and X2. It should match the readings on the transformer data plate. If you have no power or the power is over or below the ratings by 10%, replace the transformer.

4. **Operate the Keypad.** There are several different types of keypads you will encounter in the field. Visonic, HTC, IEI, Bubble type, and Intertex. Enter the code into the Keypad, default J&D = 4321# default VIDIR = 1234*. If the default code does not work, locate an associate in the department who can show you the code. Once you have entered the correct code you should see a green diode light up. On the Visonic CL4 Keypad, only the yellow diode will light up. The control voltage should now activate the up/down control switches to operate the carousel. CL4 Keypad is programmed by hard wiring the sequence on the internal wiring blocks. See the Manual at: [Anyview/Equipment/Visonic/CL-4 Keypad.pdf](#)

The **Visonic CL-4** is found on older Carousels. See below for wiring setups and troubleshooting. The code is determined by hardwiring between Row 1 and Row III.

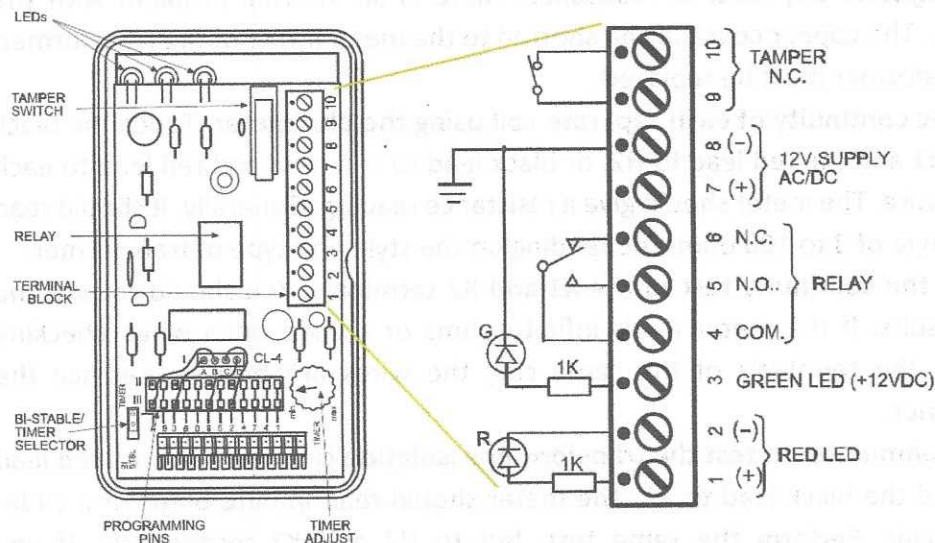

Visonic CL-4

Troubleshooting:

1. LEDs should be lighted.
2. Enter four digit code, yellow LED should light.
3. Test for 12VDC at terminals 7 and 8.
4. If no voltage at 7 and 8 test the transformer.
5. If voltage at 7 and 8 and keypad does not work replace keypad.

Carpet Carousel Advanced Troubleshooting Guide

The HTC Keypad is the current replacement for CL-4, CL-8A, and IEI 212i.

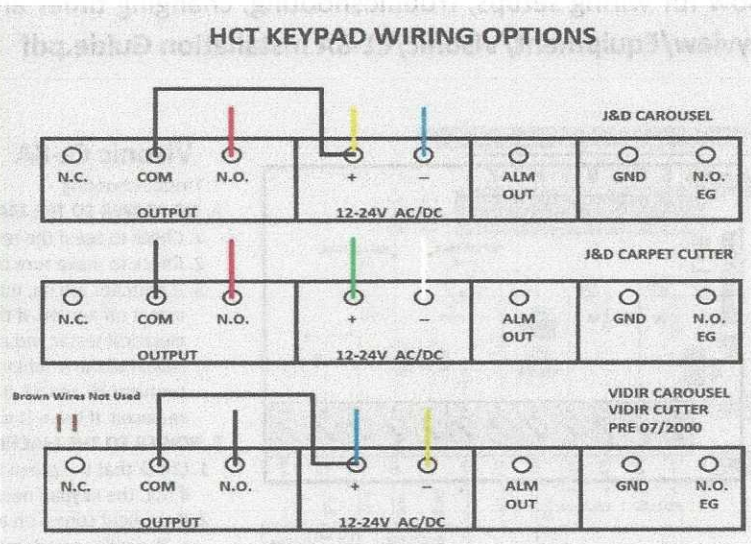
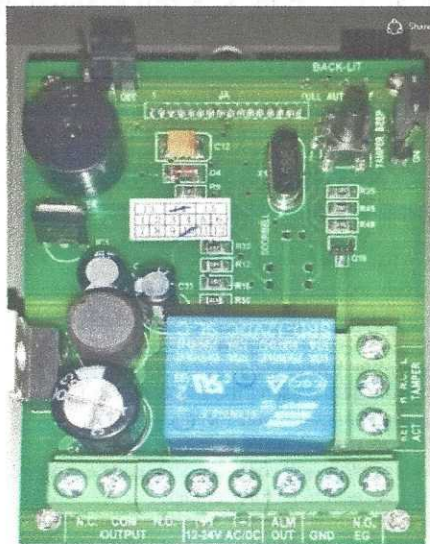

Programming 90 Second Timeout (recommended)

(Do this step every time you install an HTC keypad)

1. Cycle Power
2. * 1 2 3 4 #
3. 4
4. 9 0 # (90 can be any number from 1-90 for desired timeout)
5. Cycle power.

Reprogramming Access Code (as needed)

(This will replace the default code with whatever code you choose to enter)

1. Cycle Power
2. * 1 2 3 4 #
3. 0
4. (new code) #
5. (new code) #
6. Cycle Power

HTC Keypad Operating/Installation Tips

The keypad instructions that come with the keypad are not all correct.

1. Install the keypad as per the wiring diagram for your particular machine
2. Program the time
3. Program the user code if requested by store. The keypad should operate properly.

Some useful information for the HTC Keypad:

1. The yellow light should flash 1 time every 2 seconds when the keypad is off. This is normal
2. The default user code is 1234#. If you enter *1234# like some of the instructions imply then you will have entered programming mode and you will have to repeat the programming steps above.

Carpet Carousel Advanced Troubleshooting Guide

3. If you installed the keypad and it seems to time out after just a second or so, follow the programming instructions above in the order above.
4. Once the keypad is active you will see a white LED on the keypad in the upper left come on. This is normal operation and it will turn off after 10 seconds.

The IEI 212i Keypad is mostly found on older VIDIR Carousels. Newer VIDIR Carousels will have the Bubble Keypads. "I" designates flush mount indoor style of keypad as opposed to "se" or sealed environment style, or "r" for rugged style which has a cover and box mount. Below is the circuit board for the IEI 212i Keypad and wiring harness configuration if it has one.

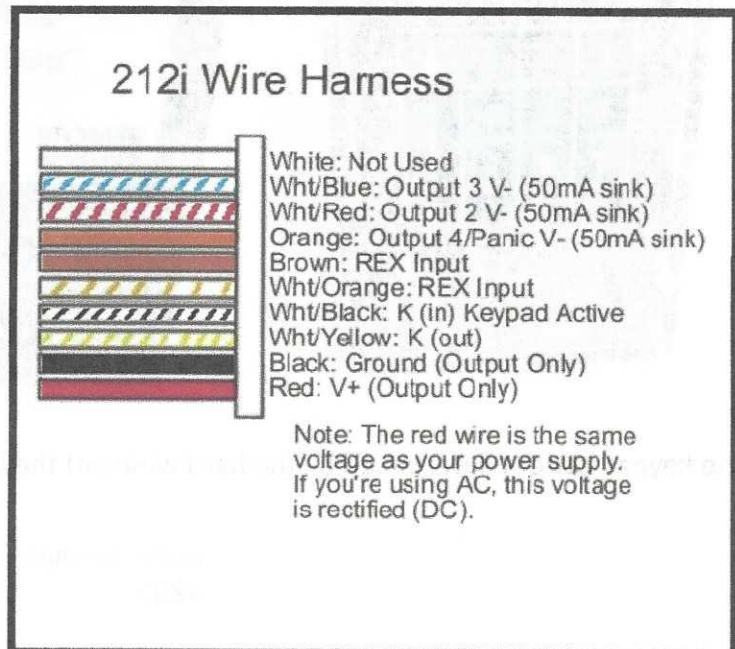
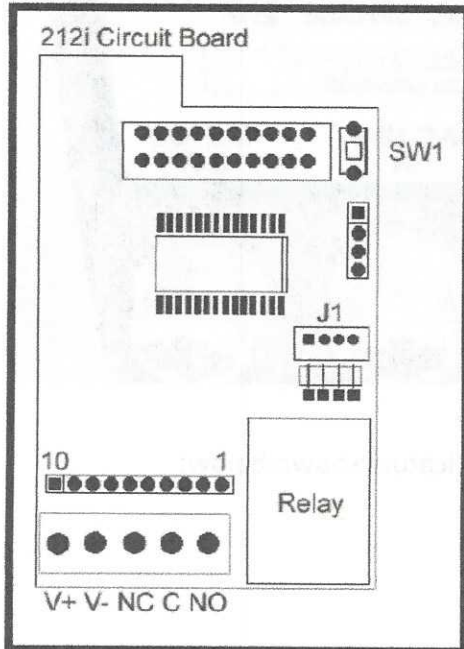

TESTING THE KEYPAD

1. Connect the positive (+) lead of your power supply to the terminal strip (TS1) +V input.
2. Connect the negative (-) lead of your power supply to the terminal strip (TS1) -V input.
3. Turn on your power supply.
4. Press 7890#123456*. If all 12 keypresses have been verified, the keypad will enter self test mode. Either the LED's will flash or the sounder will beep 3 times, then light or sound continuously for 3 seconds (except on the mullion). If these responses do not happen, try the test mode again and then call tech support. Note: self test mode can be used when troubleshooting a keypad in the field. If you do not get the continuous light or sound then the memory has been corrupt and should be re-programmed with the 46 command (see option #19).
5. Enter the master code of 1234*. The relay will energize. Refer to programming section to program your keypad.

PROGRAMMING

1. Enter programming mode

Press 90 # (master code)*

2. Change master code/set main relay time

Enter (Relay Time) # 1 #
(new code)* (repeat code)*

Example:

Master code of 4321/relay time of 90 seconds
Press 90 # 1 # 4321 * 4321 *

3. Exit programming mode

Press * Out

- If the master code is forgotten or does not seem to be working, momentarily push SW1 on the circuit board, (see wiring diagram for location) to enter programming mode and follow step two from above to program a new master code.
- If the yellow LED lights (or sounder sounds) solid while in programming mode an error has occurred. Press* to clear (yellow LED should flash or sounder sound) and start over from step 2 or 3 above.

Carpet Carousel Advanced Troubleshooting Guide

Intertex Carousel: An older model Carousel that you may encounter is called the **Intertex Carousel**. Below is the original setup for the keypad. There is a new design of the keypad that you will order when changing out these keypads that cannot be repaired. See the document at [Anyview/Equipment/Intertex/Keypad information for intertex.pdf](#).



The keypad code is determined by the hard wiring of the indicators shown below:

code example:
4280

ge = yellow
gn = green
bl = blue
rt = red

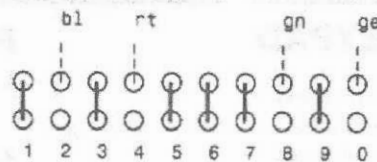

1 = jumper
3 = jumper
5 = jumper
6 = jumper
7 = jumper
9 = jumper

code example:
1234

red = first number
blue = second number
green = third number
yellow = fourth number

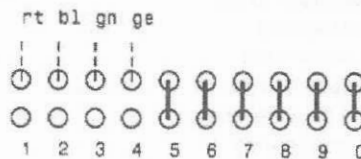

5 = jumper
6 = jumper
7 = jumper
8 = jumper
9 = jumper
0 = jumper

- Run machine up or down using the up/down button.** The switches that operate the motors are normally open momentary. When you press or turn the switch the contact is made and control voltage flows to the coil on the contactor closing the three phase circuit and power

Carpet Carousel Advanced Troubleshooting Guide

flows to the carousel motor. When you release the switch the normally open switch changes state from closed to open and the motor contactor coil is de-energized and the three phase contacts open causing the motor to stop. If you don't hear the contactor pulling in or releasing when you use the up down switches, do the following test to check the magnetic contactor:

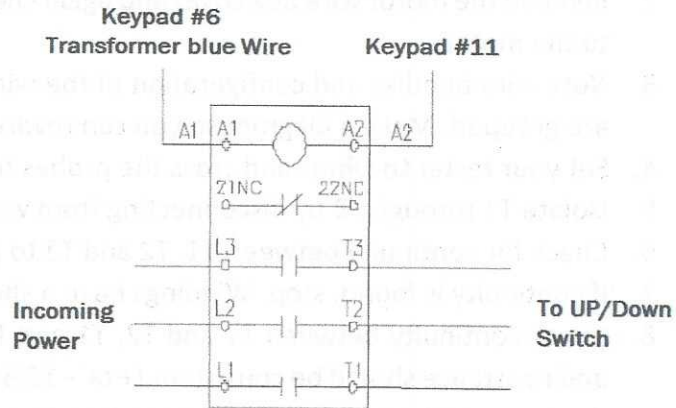

Magnetic Contactor Troubleshooting: (pictured above ABB B6-30-01-03 Mini Contactor)

Testing the coil: With power on, test voltage at A1 and A2. It should read 24 volts. Test voltage across L1 and L2, L1 and L3, L2 and L3. All should be within 10% voltage of each other at 208VAC. Isolate power to the Carousel at the breaker panel. Remove wires A1 and A2. Set meter to read Ohms and touch leads to A1 and A2 on the contactor. If you read Zero there is a short, if infinite ohms there is an open in the coil. You should read 20-300 Ohms.

Testing the contactor: With leads on L1 and T1 you should read infinite Ohms. Press the contactor in and you should read Zero. Repeat on L2 and T2, and also with L3 and T3. If contacts are closed without pressing the switch the contacts have become welded. If there is no continuity when the contactor is pressed the contacts have become burned, pitted and the contactor must be replaced. If contactor is working but motor does not run, perform the following motor test.

Testing the winding resistance on a 230/460 Volt, 3 Phase, 60 HZ., 9 Lead Motor:

Tools needed: Multimeter that can test volts, ohms, and amp clamp.

Note: most Carousel Motors are in the upper section of the machine out of reach from ground inspection. If this is the case a scissor lift will be required to perform the electrical test on most motors.

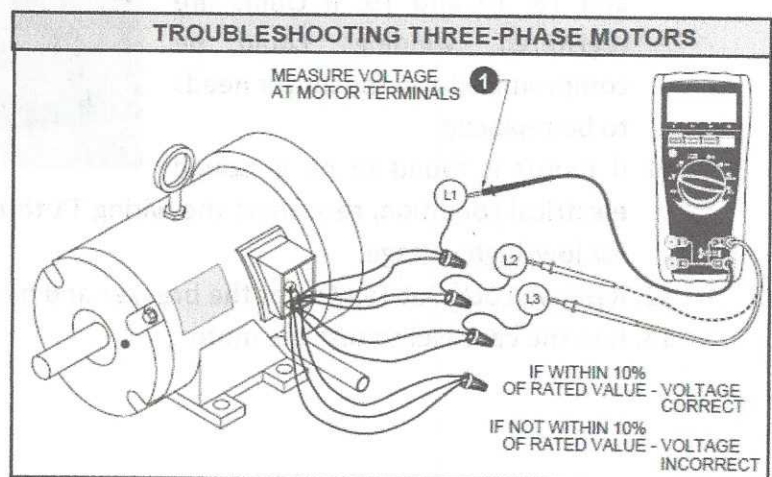

Carpet Carousel Advanced Troubleshooting Guide

1. Test incoming power at L1, L2 and L3 to check quality of voltage. In most cases this will be 208VAC on Carousels. Change meter to Amps and use the amps clamp on L1, then L2, then L3 while operating the motor. You are looking for amps to match line amperage + or - 10% of each incoming line. Power down carousel at the breaker box and Lock Out Tag Out breaker. Test for power at the overload to ensure power is off.
2. Remove the motor wire box cover and again check for voltage to ensure there is no power to the motor.
3. Note wire bundles and configuration of the wires hooked up to L1, L2, L3 and how wires are grouped. Make a diagram so you can rewire the motor properly after testing.
4. Set your tester to Ohms and cross the probes to check the reading.
5. Isolate T1 through T3 by disconnecting from wire bundles.
6. Check for continuity between T1, T2 and T3 to ground. There should be no continuity.
7. If continuity is found, stop, Windings have a short to ground. Replace motor.
8. Check continuity between T1 and T2, T1 and T3, T2 and T3. There should be continuity and resistance should be consistent (+ or - 10% as a guide) If it varies greatly, the windings are compromised and the motor needs to be replaced.
9. Now check phases of the motor by testing continuity between the phases for consistency (+ or - 10% as a guide). Isolate wires T4 through T9 by removing wire nuts. Test continuity between T1 and T4, T2 and T5, T3 and T6. If the Ohms readings vary greatly or are at 0 the windings are compromised and the motor needs to be replaced.
10. Lastly check for an absence of continuity between T1 and T7, T2 and T8, T3 and T9. If Ohms are registered, windings could be compromised and the motor needs to be replaced.
11. If motor is found to be in sound electrical condition, reconnect the wiring T1 through T9 per the wiring chart to the right for low/high voltage.
12. Remove Lock Out Tag Out at the breaker and have management energize the breaker.
13. Run the carousel to test the motor.

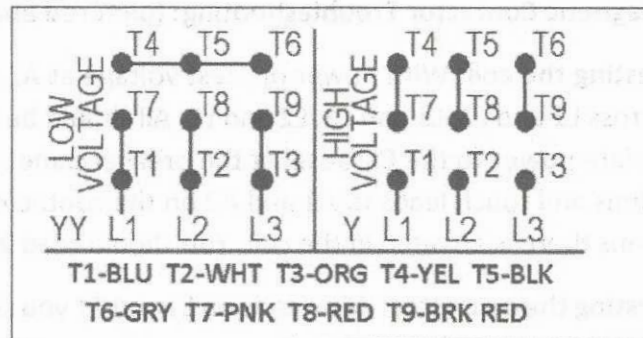

Carpet Carousel Advanced Troubleshooting Guide

Motor Bearings Issues: When bearings are dragging in the motor you will notice a much higher amps draw and the motor will heat up. If the drag is bad enough, the overheating motor will cause overloads to trip and eventually the breakers to trip.

Motor Drive Sprocket Inspection: Whenever you have a Scissors lift at your disposal take the time to do an inspection on drive sprockets on the Motor Shaft on J & D Associates carousels. You Are checking to make sure there is a key in the keyway, the sprocket is aligned with the driveshaft sprocket and set screws are tight. See photo. Arrow is pointing to the key, sprocket is aligned properly and set screws were tight in this instance.

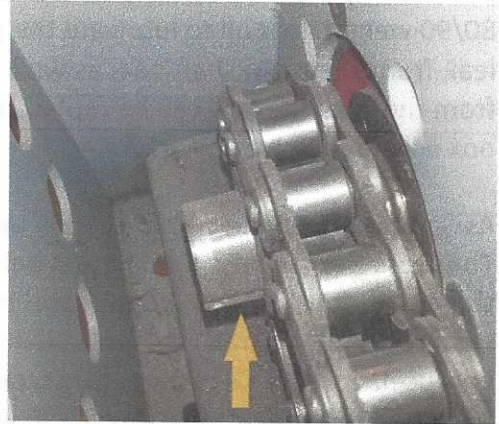

- 6. Listen and watch-** as you run the machine listen to the motor, chain and general operation. Listen for snapping, popping, squealing, or for buzzing from the motor. There are a variety of different types of carousels you will encounter in the field. Many have been running for over two decades. There are very similar mechanical components that secure the carousel, chains, motors, gear boxes in place by nuts and bolts that loosen over time, namely chain tensioners which are vital to keeping chains from popping off the sprockets. The tell tail sounds of loose tensioners are snapping, popping of the chain trying to jump the sprocket. A visual clue is that the product bars will be misaligned by a few inches and maintenance will need to be completed on the carousel to correct the issue. When they are loose enough, they will eventually completely jump off the sprocket causing equipment failure.
- 7. Test the brake.** As you stop the machine notice how much the product chain drifts. Anything more than 4" indicates a problem. Problems include, the carousel being out of balance, the brake relay is bad, the brakes are failing and the motor could need to be replaced. Troubleshoot all electrical modules to determine where the problem lies. Inform store management of imbalanced load if you find the weight is not distributed properly. Store sales can quickly empty product rolls creating the imbalance.

CPES No Climb Inspection Procedures

Years of operation in the commercial environment will cause wear and tear on carousel components. The challenge for the FSP and MSP is to determine issues exclusively from the ground. As the service company, we are not permitted to operate store lifts for inspection purposes. We cannot ask store employees to look at equipment on our behalf or use photographic devices to have store personnel take pictures on our behalf. Follow these procedures for determining any problems that may necessitate using a scissors lift for further exploration of issues.

Carpet Carousel Advanced Troubleshooting Guide

1. VIDIR Gear Box Leaks: inspected from the ground

Gear box leaks are obvious when you know what to look for. VIDIR carousels use a gear drive powered by a belt and pulley off the motor which in turn drives the load chain. This gear box has 80/90 weight gear oil to lubricate the gears as they operate. The front plate on the gear box can leak from the main shaft seal as well as the front plate of the gear box enclosure. If the leak is from the seal, the seal can be replaced. If the leak is from the front face of the gear box, the gear box will need to be replaced.

As you peer into the carousel, look up along the right and left uprights at the motor assembly. The cross beam of the upright just below the motor housing should be clean and free of drips. If there are drips on the cross beam in the upright the gear box is leaking and maintenance is required. You will need to determine the size of the seals required by the model number on the Carousel. Contact CPES parts to discover the part number for the seals. The gear oil will need to be added to the gear box. Use 80-90 weight gear oil. There is a plastic cap fitted to the top of the gear box for this purpose. Do not completely fill the gear box with oil. Only a couple ounces are required. When replacing the cap, do not overtighten as this will prevent air from escaping which will cause pressure on the oil and leaks will continue.

2. Main Keyway Visual Inspection from the ground

While climbing to inspect the gearing is no longer permitted, we are still responsible for the inspection and upkeep of all the mechanical and electrical functions on the Carousel. It is important to recognize visual clues and cues to problems and issues on the upper sprockets, keyways and gears. As you peer into the upper motor/gearing assembly on a VIDIR Carousel you will notice a hole left of center on the cover and the gear shaft with key should be visible. Run the carousel till you can see the shaft plainly on both left and right uprights. You could use a set of binoculars to check the position of the key in the keyway on this shaft. The key should be flush with the end of the shaft. If it is extending beyond the end of the shaft, there is an issue with the assembly that must be addressed using a scissors lift. The set screws will need to be loosened, key repositioned, and set screws tightened to remedy the situation.

3. Debris in Chains/Sprockets plastic/wire

As you continue your visual inspection, look closely at the upper and lower sprockets on the carousel. Note if there is plastic or debris caught in the chain and sprockets. If there is you will need to order a scissors lift to address the situation to remove the plastic or debris from the upper sprockets. If the debris is left in the chain, a catastrophic failure of equipment could occur causing the chains to slip off the sprockets and possibly injure personnel or customers.

4. The process to repair a drive chain that has jumped the sprocket is as follows:

Carpet Carousel Advanced Troubleshooting Guide

The photo shows what can happen if someone attempts to run the carousel when the chain has popped off the sprocket. It becomes trapped between the sprocket housing and the sprocket. If this happens you will need a new #80 Chain. The process is to break the chain just above and below where the chain is jammed in the frame. Then you will use a very heavy hammer and large chisel to pound the remaining jammed links out of the sprocket. You will need a #80 chain break, a large heavy hammer, large chisel, and hearing protection. Once the old chain is removed, install the new #80 chain along with new master link hardware and set the correct tension on the slack adjuster.

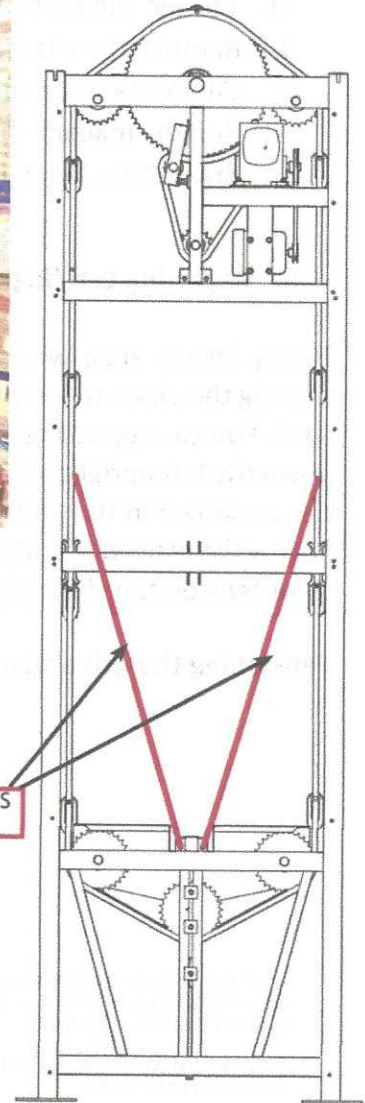

- A. You will need to work with store personnel to block off aisles when using a scissors lift during normal store hours.
- B. Anchor the left or right side load chain that has the problem drive chain so the product chain cannot move up or down.
- C. Using the carousel controls, lower the right or left side to level the product rolls or wire carriage. Measure from the floor to the product hook on the right, and then do the same on the left. Continue to adjust up or down till the measurement matches or is within 1/4" +/-.
- D. Using Scissors lift, raise up to the drive sprocket. If the chain is damaged, it will need to be replaced.
- E. Loosen the tensioner.
- F. Locate the master link, add zip ties to hold the chain together (see photo), then remove the master link.
- G. Reposition the chain around the drive sprockets and reconnect the master link.

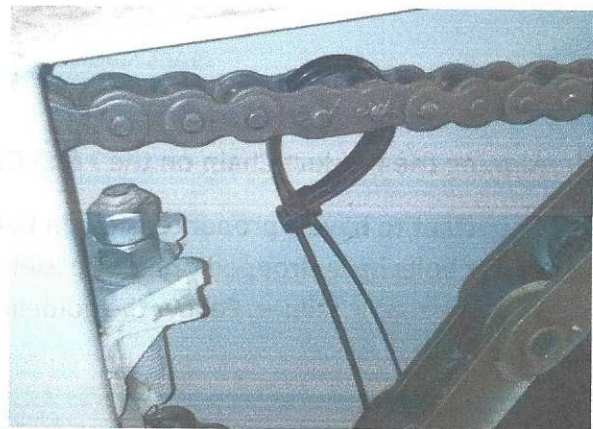

Carpet Carousel Advanced Troubleshooting Guide

- H. Tighten the tensioner and check the drive chain deflection. Remove the zip ties.
- I. Remove the chain blocks on the left or right side of the product chain.
- J. Check the drive chain tension on both drive chains, adjust as necessary.
- K. Run the machine five minutes in each direction and recheck the deflection on the repaired drive chain. Readjust if needed per tensioning directions below.

5. Repairing Left/Right Timing issues Carpet/Wire

Timing issues arise when tensioners are not set correctly, or one tensioner has come loose causing the chain to jump the sprocket. You will notice the product poles or wire carriages aren't level. You can repair the situation similar to the process of repairing the broken drive chain. Lock down the left upright load chain. Loosen the tensioner on the left drive chain assembly. Insert zip ties as shown in the photo above to hold the chain together when you remove the master link. Follow the procedures above to align the product bar/wire carriage. Follow the procedures below to re-tension the slack adjusters and product chain tensioners.

Tensioning the drive chain with the slack adjusters on a J & D Carousel:

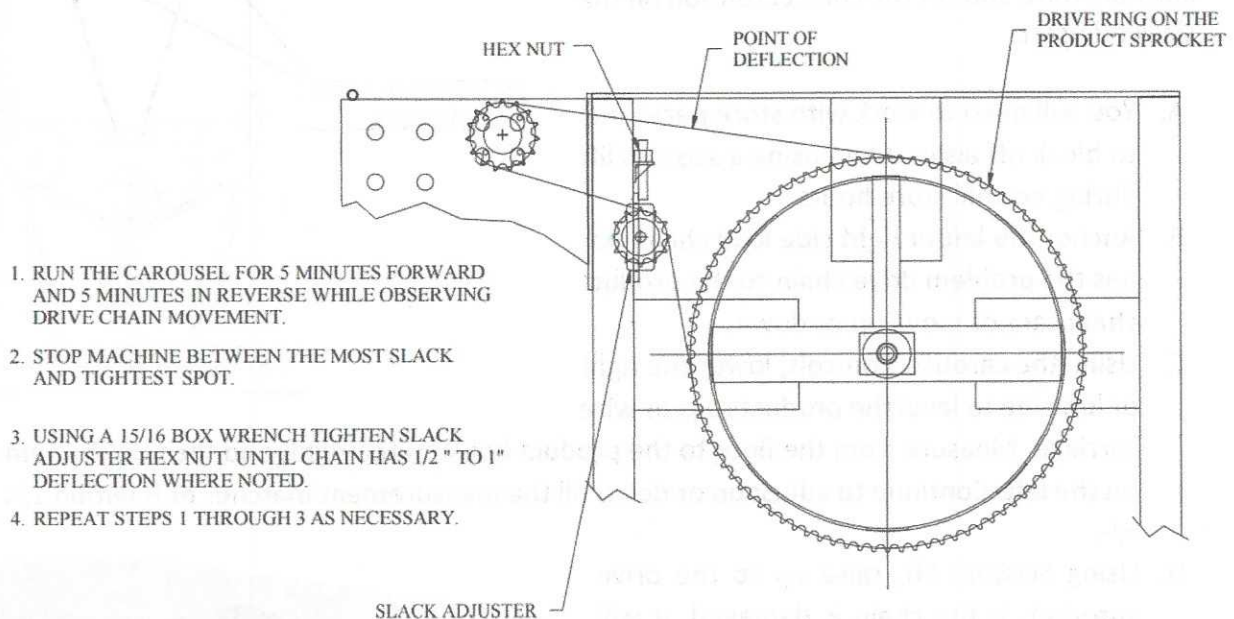

Tensioning the Product Chain on the J & D Carousel:

It's important to have a proper tension on the product chain. If the chain is too loose or the tensioner bolts have dropped out it's possible the chain will pop off the bottom sprocket and cause catastrophic failure. Follow the guidelines below for setting the proper tension on the product chain.

Carpet Carousel Advanced Troubleshooting Guide

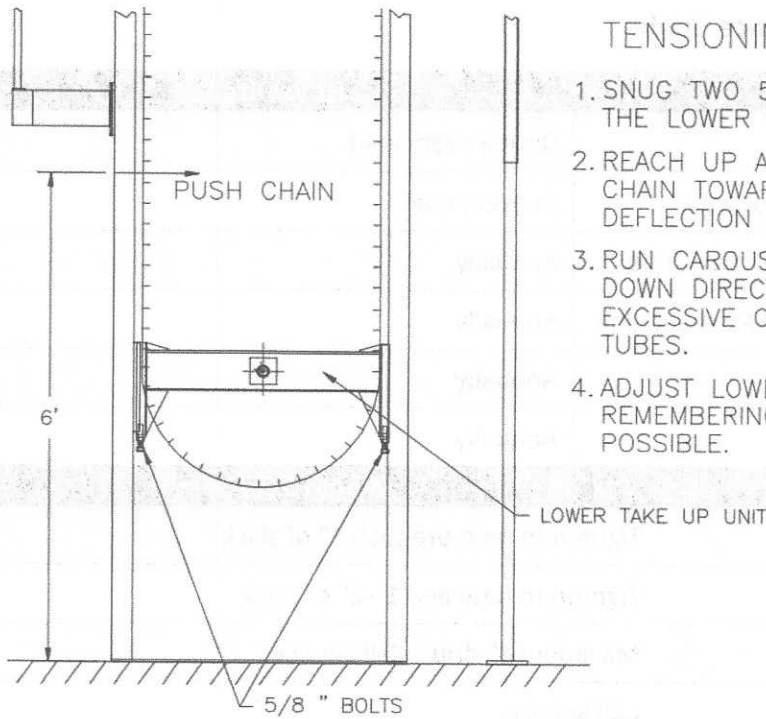

TENSIONING THE PRODUCT CHAIN

1. SNUG TWO 5/8 BOLTS EVENLY ON THE LOWER TAKE UP UNIT.
2. REACH UP AS SHOWN AND PUSH CHAIN TOWARDS BACK OF CAROUSEL. DEFLECTION SHOULD BE ABOUT 1" UNLOADED.
3. RUN CAROUSEL IN BOTH THE UP AND DOWN DIRECTION AND LISTEN FOR EXCESSIVE CHAIN SLAP ON THE UPRIGHT TUBES.
4. ADJUST LOWER TAKE UP ACCORDINGLY REMEMBERING TO KEEP LTU AS LEVEL AS POSSIBLE.

Product Chain Adjustment

NOTE: TO ENSURE PROPER LUBRICATION OF ALL CHAINS- LUBRICATE BETWEEN SIDE PLATES AND ROLLERS INDICATED BELOW #1 AND #2.

Inspect the Condition of the Product Chain:

Use 30 weight oil with a sponge brush to apply oil to product chain as shown to the right.

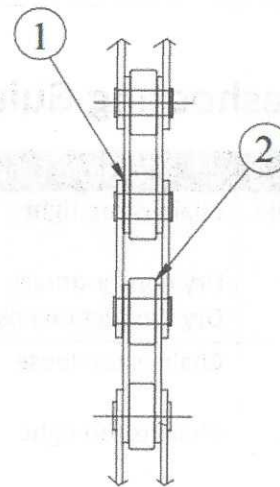

Product Chain Lubrication Points

Carpet Carousel Advanced Troubleshooting Guide

J & D Basic Preventative Maintenance Guide

What to Check	How Often
Inspect Hooks	During every load
All Product Poles for bends, damage or wear	At every load
Lubricate Drive Chains using 30W SAE chain lube	Annually
Lubricate Product Chains using 30W SAE chain lube	Annually
All Fasteners for tightness as needed	Annually
Operation of Emergency-Stop	Annually

What to Check	What to Do
Drive Chain tension	Tighten to no more than 1" of slack
Product Chain tension	Tighten to between 1"-2" of slack
Brake Operation	Maximum 4" drift - Call Service
Motor Sprocket	Call Service
All Anchor Bolts	Torque- 70 Ft-lbs-5/8 Anchors 120Ft-lbs-3/4 Anchors
All Mounted Accessories	Torque to 35 Ft-lbs.
All Hooks, Latches, & Springs	Replace any damaged parts immediately
All Product Poles	Replace any damaged poles immediately
Hook Replacement	Recommended @ 1000 hours service – Call Service
Debris on Upper Sprocket Assy	Inspect Upper Sprocket Assy for plastic or debris – Clean as needed

J & D Troubleshooting Guide

Problem	Possible Cause	Solution
Squealing noise while running	Chain is too tight	Adjust Product Chain Tensioners to 1" deflection
	Dry hook journals	Lube hook journals
	Dry Product Chains	Lube right and left product chains
Chains are noisy	Chain is too loose	Adjust Product Chain Tensioners to 1" deflection
	Chain is too tight	Adjust Product Chain Tensioners to 1" deflection
	Chain is dry	Lube Chain w/30W SAE
	Chain is out of alignment	Repair Sprocket hub bearings

Carpet Carousel Advanced Troubleshooting Guide

Product drifts more than 4" after the button is released	System is out of balance Brake is slipping, out of adjustment	Balance System Motor will need to be replaced (we don't repair)
	Delayed Brake	Bad relay, troubleshoot and replace
System runs slowly	Low voltage Brakes dragging	Check Voltage(208v Minimum) Motor will need to be replaced (we don't repair)
	Open phase	Store Management contacts electrician
System Alternates between Fast & Slow running or machines runs Erratically	System out of balance	Re-balance load
Control System Does not work	E-stop depressed Reset button not activated	Press Reset button in Troubleshoot overload switch, replace if needed
System trips breaker(s) regularly	Short circuit	Troubleshoot to find short circuit
	Low voltage	Check voltage (208v min)
	Faulty component	Troubleshoot, Repair, Replace Component
Motor hums but won't move	Open phase	Check electrical service, have management reset breakers
	Low Voltage	Store Management contacts electrician
	Brake not releasing	Troubleshoot relay Replace motor
Motor won't run or make any noise	No power to system	Check controls Check Access Code Check Store Breakers Press Reset button Check Voltage Supply Store Management contacts electrician
Stops running while in use	Running time elapsed	Re-enter access code
	Loss of power	Check to see if circuit Breakers are on

The VIDIR Carpet/Vinyl Carousel has a different design than the J & D Associates Carpet/Vinyl Carousel. The basic operation, loading and care is very similar. The VIDIR Carousel also needs to be balanced, as do any Carousel regardless of Manufacturer. Other Manufacturers of Carousels include: Intertex, FabTech, and Strohmeier. Please refer to the **VIDIR Carpet Vinyl Carousel Manual 6-23-15** for repair procedures, troubleshooting, and preventative maintenance instructions. You can find the file in Anyview:

/Equipment/Vidir/Carousel, Carpet/Technical/Vidir Carpet Vinyl Carousel Manual 6-23-15.pdf

Carpet Carousel Advanced Troubleshooting Guide

VIDIR Carousel Troubleshooting Guide

Symptoms/Problems	Solution
Carousel will not run	<ul style="list-style-type: none"> A. Re-enter the security code. B. Check if the master switch is on. C. Check and reset circuit breaker. D. Make sure machine load is evenly balanced.
Motor lugs down or breaker trips	<ul style="list-style-type: none"> A. Make sure machine load is evenly balanced. B. Check and reset circuit breaker.
Carousel is noisy	<ul style="list-style-type: none"> A. Tighten set screws on pulley and/or tighten belt (replace if necessary). B. Check for correct chain alignment. C. Oil the carousel chains.
Carousel is dead, no lights on the keypad	<ul style="list-style-type: none"> A. Turn power switch to the on position B. Check breaker in the main panel. (trip off and on) C. Turn power switch off and wait 30 seconds. Check for 208 volts between all 3 phases D. Check for 24 volts at the key pad (6-7 on Visonic) or (+ - on the IEI) E. Check voltage on the primary side of the transformer. (208 volts ac) F. Check voltage on the secondary side of transformer. (24 volts ac) G. Check wire connections from transformer to the key pad. H. Check key pad voltage setting (no jumper on JP3 Visonic) (no jumper on J2 on the IEI keypad)
Carousel has lights on the key pad but is dead	<ul style="list-style-type: none"> A. Ensure the yellow light blinks for each key stroke. (IEI keypad only) B. Listen for a click when entering the code. C. Watch for the green light on the IEI keypad. D. Reprogram the key pad (IEI only) E. Move the wire on (NO terminal → NC on the IEI key pad) (on Visonic move the wire on terminal #11 → 12). This bypasses the keypad and unit will be live all the time. F. Check wire connections from the key pad to the push buttons. G. Check wire connections from the push buttons to the contactors
Carousel buzzes or runs as soon as the code is entered	<ul style="list-style-type: none"> A. Check to ensure the up and down push buttons are not stuck on. B. Check for correct wiring. (after upgrading old style contactor)
Carousel buzzes or runs as soon as the power is turned on.	<ul style="list-style-type: none"> A. Check for a stuck contactor. B. Check for correct wiring. (after upgrading old style contactor).
Carousel will not shut off after 30 seconds of usage.	<ul style="list-style-type: none"> A. Reprogram keypad. B. Replace keypad.

Carpet Carousel Advanced Troubleshooting Guide

Symptoms/Problems	Solution
Carousel strains and comes to a stop.	A. Check for an obstructions in the machine B. Check for an off balanced load. (max difference front to rear is 1500 lbs) C. Check to ensure that the key is in place on the gear box output sprocket. (both sides)
Carousel will only rotate in one direction	A. Check to ensure that the load is distributed evenly. B. Check that the up and down buttons each energize a contactor. C. Check for a faulty contactor. D. Check for correct wiring. E. Ensure all wire connections at the contactors.
Carousel will rotate but is noisy and squeaks.	A. Oil the load chain. B. Check chain tension. C. Lubricate the hook bolts. D. Tighten the setscrews on motor and gear box pulleys.
Carousel will not rotate in either direction but makes a buzzing noise.	A. Check if breaker is turned off (trip off and then back on) B. Check if the load is balanced properly
Correcting a machine jam up because of an off balanced load.	A. Jog carousel up or down with short jabs on the up or down buttons. If the chains move you may be able to walk the unit out of its jammed position. (If the carousel won't move do not press the buttons for an extended length of time this could ruin the motors) B. Unload a roll(s) from the heavy side of carousel. C. Load a roll (s) on to the light side of the carousel. D. Un-jam the gear boxes by rotating the pulley on the gear box. (Locked pulley needs to be rotated by hand, either direction, about 1/8 turn or until pressure is released).

Working off of a Scissors Lift: Whenever there is work to be done up at the top of a carousel such as removing plastic from upper sprockets, inspecting motor, drive sprockets, chains, a scissors lift is required along with fall arrester gear and hard hat.

The scissors lift and safety gear must be inspected before use to insure it is in good condition and ready for use. Every person using the scissors lift must read the manufacturer's operating manual and have operating knowledge for the safety operation procedures.

1. Read scissors lift owner's manual and be familiar with safety procedures while operating the lift.
2. Inspect scissors lift and personal safety gear before using.
3. Use a GFCI cord if power tools will be used from the lift.

Carpet Carousel Advanced Troubleshooting Guide

J & D Associates Carousel Control Box Parts List (Updated 2/12/2016)

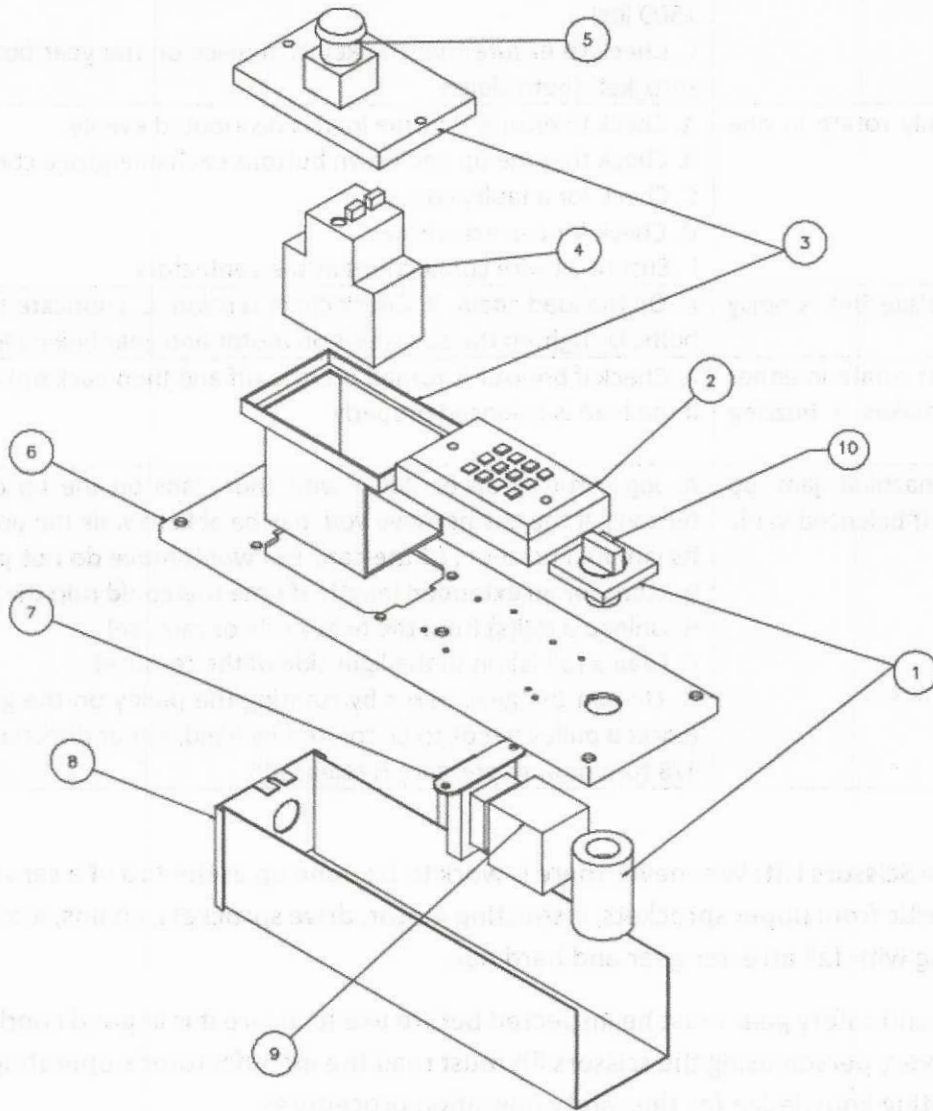

10	1	UP/ DOWN SELECTOR KNOB		ELECP01A
9	1	MINI CONTACTOR	ABB B6-30-01, 24VAC, 3NO / 3NC	ELE0013A
8	1	REAR COVER	12-1/2"x 3"x 3-3/8" FORMED SHEET	ELE0137
7	1	CONTROL TRANSFORMER	PROD. UNLIM. 4000-02A19K34, 240VAC-24VAC, 10VA, XF-0331	ELE0025C
6	1	CONTROL PANEL FRONT PLATE	15"x 4-1/2"x 1/2", 12 GA FORMED PLATE	
5	1	E-STOP MUSHROOM BUTTON	AEG 910-293-108 (OR CUTLER HAMMER C320MSE2)	ELE0134
4	1	MOTOR PROTECTOR	AEG 910-201-208, 4 - 6.3 A, (OR CUTLER HAMMER A302JN)	ELE0011A
3	1	MOUNTING PLATE	AEG MBS25-SF4 (OR CUTLER HAMMER 799FP41)	ELE0012
2	1	KEYPAD	VISIONIC CL-8	410-0024
1	1	UP / DOWN SELECTOR SWITCH	KRAUS & NAIMER, CA10US6447600FT2, F273 NP, G521 HANDLE	ELECP01
ITEM	QTY	PART NAME	PART SPECIFICATIONS	SYMIX/DWG NUMBER

Carpet Carousel Advanced Troubleshooting Guide

J & D Associates Carousel Schematics

