



Push-button Control Retrofit Instructions for GQB & GQF Including Replacement of Friction Wheel with Gear Assembly

These instructions are intended for use by technicians and others while replacing older controls and/or friction drive wheel assemblies with special push-button controls and/or gear drive assemblies. The process is specifically designed for GQF and GQB paint mixers. If you encounter difficulty executing these retrofit instructions, contact the Fluid Management Customer Service department at 1 (800) 462-2466.

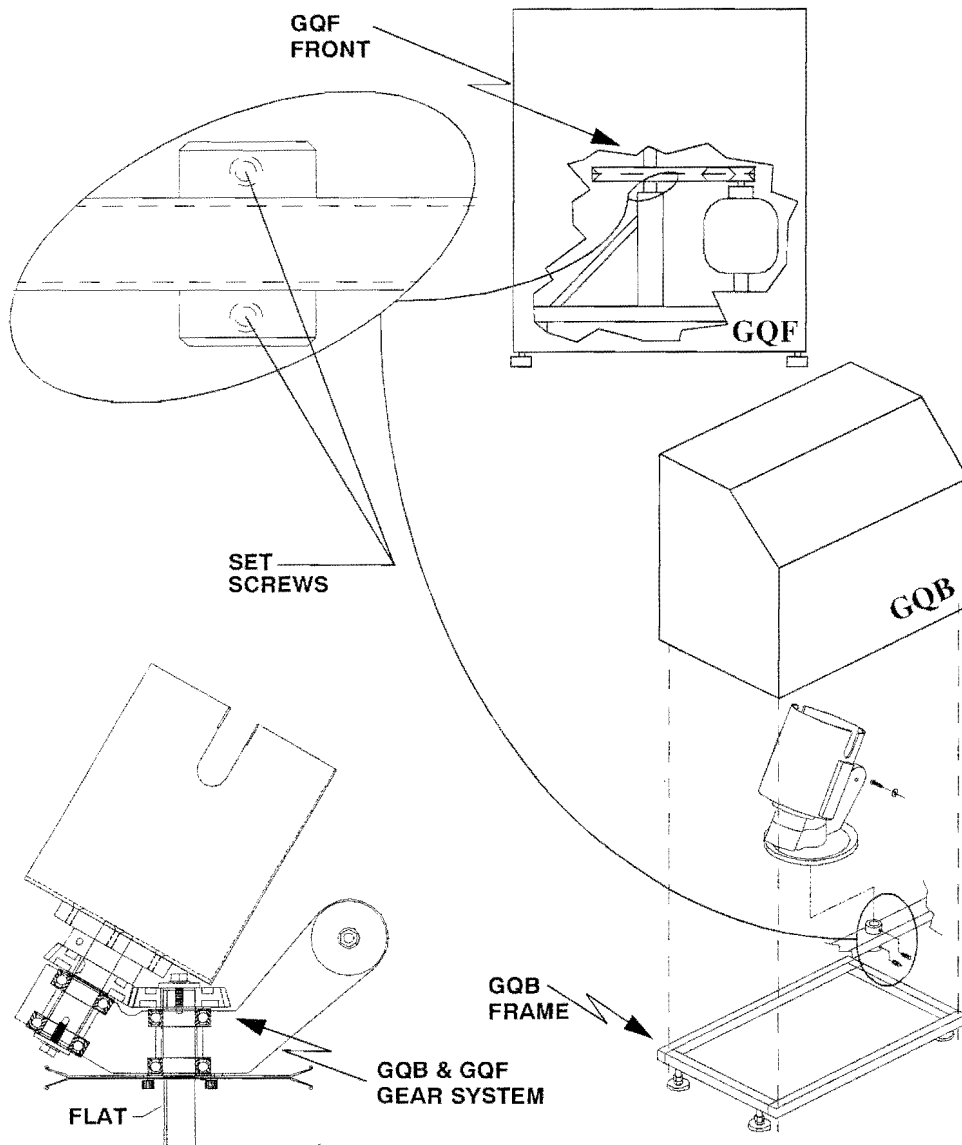

Figure 1 GQB & GQF Drive System

1023 Wheeling Road
Wheeling, Illinois 60090

Part # 24350
Rev. B 06/23/99

Voice (800) 462-2466
(847) 537-0880
FAX (847) 537-5530