



an EnPro Industries company

# QT<sup>®</sup> & PLT<sup>®</sup> Industrial & Air Master Series 2 Stage Compressors

Instruction Manual

This manual contains important safety information and should be made available to all personnel who operate and/or maintain this product. Carefully read this manual before attempting to operate or perform maintenance on this compressor

Manual No. 50161-105

October 2004 Edition



# WARRANTY

Quincy Compressor

Industrial Reciprocating Products

QT & PLT Industrial / Air Master Two Stage Compressors

## GENERAL PROVISIONS

Quincy Compressor (The Seller) warrants to each retail purchaser (Purchaser) products of the Seller's own manufacture against defects in material and workmanship. With respect to products not manufactured by the Seller, the Seller will, if practical, pass along the warranty of the original manufacturer.

The Seller's sole obligation under this warranty shall be, at its option, to repair, replace, or refund the purchase price of any product or part thereof which is deemed to be defective, provided the Purchaser meets all of the applicable requirements of this warranty and none of the limitations apply.

## WARRANTY PERIODS

### Basic Compressors

Seller warrants for twelve (12) months from date of start-up or twenty-four (24) months from factory shipment, whichever occurs first. This includes labor and approved travel. All warranty travel expense will be paid to the nearest authorized repair center.

### Remanufactured Basics

Seller warrants for six (6) months from date of start-up or eighteen (18) months from date of factory shipment, whichever occurs first. This includes labor and approved travel. All warranty travel expense will be paid to the nearest authorized repair center.

### Replacement Parts

Seller warrants repaired or replaced parts of its own manufacture against defects in material and workmanship under normal use and service for ninety (90) days, or for the remainder of the warranty on the product being repaired, whichever is longer.

Parts purchased outside the compressor's warranty period are warranted for ninety (90) days from the date of distributor sale, or one (1) year from the date of shipment from the factory, whichever occurs first.

Normal maintenance items and procedures are not warranted unless found to be defective in material or workmanship, i.e. but not limited to filters, gaskets, rings, valves and control lines.

### Limitations

Notice of the alleged defect must be given to the Seller in writing with all identifying details, including serial number, model number, type of equipment and date of purchase within thirty (30) days of discovery of same during the warranty period. If requested by Seller, such product or product thereof must be promptly returned to Seller, freight collect for inspection.

The Seller must have the warranty registration card on file at Quincy, IL. within ten (10) days of start-up or the warranty may be declared null and void.

The above warranties shall not apply and Seller shall not be responsible nor liable for:

- (a) Consequential, collateral or special losses or damages.
- (b) Equipment conditions caused by fair wear and tear, abnormal conditions, accident, neglect or misuse of equipment, improper storage or damages resulting during shipment.
- (c) Deviation from operating instructions, specifications or other terms of sales.
- (d) Labor charges, loss or damage resulting from improper operation, maintenance or repairs made by person(s) other than Seller or Seller's authorized service station.
- (e) Improper application or installation of product.
- (f) Warranty travel expense is not covered on QT-5 & PLT-5 compressors sold as basics.

### Disclaimer

In no event shall Seller be liable for any claims, whether arising from breach of contract or warranty or claims of negligence or negligent manufacture, in excess of the purchase price.

**This warranty is the sole warranty of Seller and any other warranties, express, implied in law or implied in fact, including any warranties of merchantability and fitness for particular use, are hereby specifically excluded.**

# Contents

<b>SECTION 1</b>	<b>SAFETY</b>
Safety First .....	1
Summary of Changes .....	3
<b>SECTION 2</b>	<b>SYSTEM DYNAMICS</b>
Description & Application .....	4
Principles of Compression Cycles .....	4
Principles of Lubrication Systems .....	4
Principles of Cooling Systems .....	5
Principles of Dryers & Filters .....	5
Specifications .....	6
<b>SECTION 3</b>	<b>INSTALLATION</b>
Receiving Delivery .....	7
Freight Damage .....	7
Location .....	8
Electrical Supply Requirements .....	9
Wiring & Piping Schematics .....	10
Mounting .....	17
System Components .....	17
Induction System .....	19
Compressed Air Discharge System .....	19
<b>SECTION 4</b>	<b>START-UP &amp; OPERATION</b>
Pre-Starting Checklist .....	23
Initial Starting & Operating .....	24
Daily Starting Checklist .....	25
<b>SECTION 5</b>	<b>MAINTENANCE &amp; LUBRICATION</b>
Stopping for Maintenance .....	26
Maintenance Schedule .....	26
Maintenance Schedule Checklist Sample .....	26
Lubrication .....	28
Pulley / Sheave Alignment & Belt Tension .....	29
Pressure Switch Adjustment .....	30
Torquing Cylinder to Head Capscrews .....	31
Pilot Valve Adjustment Instructions .....	32
<b>SECTION 6</b>	<b>TROUBLESHOOTING</b>
Troubleshooting .....	33
<b>SECTION 7</b>	<b>REFERENCE INFORMATION</b>
Decal Locations .....	37

*Safety First*

At Quincy Compressor safety is not only a primary concern, but a faithfully performed practice. Beginning with the design stage, safety is built into “The World’s Finest Compressor”. It is the intention of this manual to pass along the “safety first” concept to you by providing safety precautions throughout its pages.

“**DANGER !**”, “**WARNING !**”, and “**CAUTION !**” are displayed in large bold capital letters in the left hand column to call attention to areas of vital concern. They represent different degrees of hazard seriousness, as stated below. The safety precaution is spelled out in bold upper and lower case letters in the right hand column.

**DANGER !**

**Immediate hazards which will result in severe personal injury or death.**

**WARNING !**

**Hazards or unsafe practices that could result in personal injury or death.**

**CAUTION !**

**Hazards or unsafe practices which could result in minor personal injury, product or property damage.**

Each section of this instruction manual, as well as any instructions supplied by manufacturers of supporting equipment, should be read and understood prior to starting the compressor. If there are any questions regarding any part of the instructions, please call your local Quincy distributor, or the Quincy Compressor factory before creating a potentially hazardous situation. Life, limb, or equipment could be saved with a simple phone call.

Compressors are precision high speed mechanical equipment requiring caution in operation to minimize hazard to property and personnel. There are many obvious safety rules that must be observed in the operation of this type of equipment. Listed below are some additional safety precautions that must be observed.

- Transfer of toxic, dangerous, flammable or explosive substances using Quincy Compressor products is at the user’s risk.
- Turn off and lockout/tagout (per OSHA regulation 1910.147) the main power disconnect switch before attempting to work or perform any maintenance.
- Do not attempt to service any part of the unit while it is operating.
- Per OSHA regulation 1910.147, relieve the system of all pressure before attempting to service any part of the unit.
- Allow ample time for the compressor to cool before performing service procedures. Some surface temperatures exceed 350°F when the compressor is operating.

- Do not operate the unit with any of its safety guards, shields, or screens removed.
- Do not remove or paint over any DANGER!, WARNING!, CAUTION!, or instructional materials attached to the compressor. Lack of information regarding hazardous conditions can cause property damage or personal injury.
- Periodically check all pressure relief valves for proper operation.
- Do not change the pressure setting of the pressure relief valve, restrict the function of the pressure relief valve, or replace the pressure relief valve with a plug.
- Do not install a shutoff valve in the compressor discharge line without first installing a pressure relief valve of proper size and design between the shutoff valve and the compressor.
- Do not use plastic pipe, rubber hose, or lead-tin soldered joints in any part of the compressed air system.
- Alterations must not be made to this compressor without Quincy Compressor's approval.
- Be sure that all tools, shipping and installation debris have been removed from the compressor and installation site prior to starting the compressor.
- Do not operate the compressor in excess of the ASME pressure vessel rating for the receiver or the service rating of the compressor, whichever is lower.
- Make a general overall inspection of the unit daily and correct any unsafe situations. All fasteners must be kept tight.
- Reckless behaviour of any kind involving compressed air is dangerous and can cause very serious injury to the participants.
- Provisions should be made to have the instruction manual readily available to the operator and maintenance personnel. If for any reason any part of the manual becomes illegible or the manual is lost, have it replaced immediately. The instruction manual should be read periodically to refresh one's memory. It may prevent a serious or fatal accident.
- Never use a flammable or toxic solvent for cleaning the air filter or any parts.

## **DANGER !**

**Air used for breathing or food processing must meet OSHA 29 CFR 1910.134 or FDA 21 CFR 178.3570 regulations. Failure to do so may cause severe injury or death.**

The owner, lessor or operator of any compressor unit manufactured by Quincy Compressor is hereby warned that failure to observe the safety precautions and procedures outlined in this manual may result in serious personal injury, damage to property, and may void your warranty. Quincy Compressor must authorize all warranty service. Before contacting your distributor or the factory, check the maintenance requirements and the

troubleshooting guide for your compressor. Most warranty issues can be resolved by following proper maintenance procedures.

Quincy Compressor neither states as fact, nor in any way implies that the above list of safety precautions is an all inclusive list, the observance of which will prevent all damage to property or injury to personnel.

Every effort has been taken to ensure that complete and correct instructions have been included in this manual. However, possible product updates and changes may have occurred since this printing. Quincy Compressor reserves the right to change specifications without incurring any obligation for equipment previously or subsequently sold.

***Summary of Changes to This Manual***  
***(since previous printing dated December 2001):***

- Pilot valve adjustment instructions was added

### ***Description & Application***

Quincy Compressor QT Series and PLT Series compressors are heavy duty, air cooled, belt driven compressors. QT Series two stage compressors are splash lubricated and capable of delivering 175 PSIG of compressed air. The PLT Series compressors are pressure lubricated and capable of delivering 175 PSIG of compressed air.

### ***Principles of Compression Cycles***

#### **Two Stage Compressors**

During the downstroke of the piston of a two stage compressor, air is drawn through an intake valve in the head of the compressor into the low pressure cylinder and compressed during the upstroke of the piston.

The compressed air is then released through a discharge valve in the head of the compressor to an intercooler (usually finned tubing) where the heat resulting from compression is allowed to dissipate. The cooler compressed air is then drawn into a second compression cylinder, the high pressure cylinder, for compression to final pressure.

From there the compressed air is released through a discharge valve to an air receiver tank or directly to a network of compressed air supply lines. In one revolution of the crankshaft a compression cycle is completed.

### ***Principles of Lubrication Systems***

#### **Splash Lubricated Compressors (QT Series)**

With each stroke of the compressor, a dipper attached to the bottom of the connecting rod, dips into an oil bath at the bottom of the crankcase. This dipper splashes oil throughout the interior of the crankcase, lubricating all moving parts.

It is important with this system that the correct oil level be maintained. If the oil level is too high, excessive oil carryover could result. If the oil level is too low, or the compressor is not operated within the correct RPM range, the moving parts will not be adequately lubricated.

#### **Pressure Lubricated Compressors (PLT Series)**

Moving parts within the crankcase are supplied with lubrication by a positive displacement, gerotor type oil pump. Oil is drawn up from the bottom of the crankcase to the oil pump through an oil sump strainer screen. Oil travels under pressure through drilled journals in the crankshaft to lubricate crankshaft bearings and connecting journals.

#### **Optional Low Oil Level Switch**

QT-5, PLT-5, QT-7.5, PLT-7.5 & QT-10 compressors are available with an optional low oil level switch. A separate instruction manual is available which explains the operation, retrofit installation, and removal for inspection of the low oil level switch. Request instruction manual # 112210-101.



## ***Principles of Cooling Systems***

Fan blades of the compressor sheave force ambient air across fins of the cylinder head(s), and intercooler fins of two stage compressors, to cool the compressor. These compressors are designed to operate in a counterclockwise rotation. QT & PLT series compressors should be operated in temperatures under 104°F.

## ***Principles of Dryers & Filters***

Moisture occurs naturally in air lines as a result of compression. Moisture vapor in ambient air is concentrated when pressurized and condenses when cooled in downstream air piping. Compressed air dryers reduce the moisture vapor concentration and prevent water formation in compressed air lines. Dryers are a recommended companion to filters, aftercoolers, and automatic drains for improving the productivity of compressed air systems.

Water and moisture vapor removal increases the efficiency of air operated equipment, reduces contamination and rusting, increases the service life of pneumatic equipment and tools, prevents air line freeze-ups, and reduces product rejects.

## *Specifications*

		<b>QT-5 / PLT-5</b>	<b>QT-7.5 / PLT-7.5</b>	<b>QT-10</b>
<b>Cylinder Bore Dia.</b>	<b>H.P.</b>	2.250 / 2.251	2.500 / 2.501	2.753 / 2.752
	<b>L.P.</b>	4.00 / 4.001	4.502 / 4.503	5.003 / 5.002
<b>Piston Skirt Dia.</b>	<b>H.P.</b>	2.247 / 2.246	2.497 / 2.496	2.749 / 2.748
	<b>L.P.</b>	3.995 / 3.994	4.499 / 4.498	4.997 / 4.995
<b>Piston / Cylinder Clearance at Skirt</b>	<b>H.P.</b>	0.003 / 0.005	0.003 / 0.005	.003 / .005
	<b>L.P.</b>	0.005 / 0.007	0.003 / 0.005	.005 / .008
<b>Crankshaft Dia. journals</b>	<b>main bearing (pulley end)</b>	1.2500 / 1.2495	1.2500 / 1.2495	1.7500 / 1.7495
	<b>main bearing (opposite pulley end)</b>	1.1819 / 1.1812	1.3788 / 1.3781	1.5756 / 1.5749
	<b>main bearing (opposite pulley end)</b>	1.1819 / 1.1812	1.1819 / 1.1812	1.3788 / 1.3781
<b>Housing Bore (pulley end)</b>		2.4409 / 2.4419	2.8346 / 2.8351	3.1506 / 3.1496
<b>Main Bearing (opposite pulley end)</b>		2.4409 / 2.4419	2.4409 / 2.4419	2.8349 / 2.8344
<b>Crankshaft End Play</b>		N/A	N/A	N/A
<b>RPM Range</b>	<b>electric</b>	400-1000 RPM	500-1060 RPM	400-1000 RPM
	<b>gas</b>	1060 RPM	1060 RPM	
		<b>QT-15 / PLT-15</b>	<b>QT-54</b>	
<b>Cylinder Bore Dia.</b>	<b>H.P.</b>	2.500 / 2.501	2.000 / 2.001	
	<b>L.P.</b>	4.502 / 4.503	2.750 / 2.751	
<b>Piston Skirt Dia.</b>	<b>H.P.</b>	2.4985 / 2.4980	1.9955 / 1.9945	
	<b>L.P.</b>	4.499 / 4.498	2.7455 / 2.7445	
<b>Piston / Cylinder Clearance at Skirt</b>	<b>H.P.</b>	0.0015 / 0.0030	.0045 / .0065	
	<b>L.P.</b>	.003 / 0.005	.0045 / .0065	
<b>Crankshaft Dia. journals</b>	<b>main bearing (pulley end)</b>	1.7500 / 1.7495	1.1250 / 1.1245	
	<b>main bearing (opposite pulley end)</b>	1.5753 / 1.5749	1.1816 / 1.1812	
	<b>main bearing (opposite pulley end)</b>	1.3785 / 1.3781	1.1816 / 1.1812	
<b>Housing Bore (pulley end)</b>		3.5433 / 3.5442	2.442 / 2.441	
<b>Main Bearing (opposite pulley end)</b>		2.8341 / 2.8346	2.442 / 2.441	
<b>Crankshaft End Play</b>		N/A	N/A	
<b>RPM Range</b>		400-1150 RPM	550-1420 RPM	

### *Receiving Delivery*

Immediately upon receipt of compressor equipment and prior to completely uncrating, the following steps should be taken:

- Step 1)** Inspect compressor equipment for damage that may have occurred during shipment. If any damage is found, demand an inspection from the carrier. Ask the carrier how to file a claim for shipping damages. (Refer to **SECTION 3, *Freight Damage*** for complete details.) **Shipping damage is not covered by Quincy Compressor warranty.**
- Step 2)** Insure that adequate lifting equipment is available for moving the compressor equipment.

## **WARNING !**

**Improper lifting can result in component or system damage, or personal injury. Follow good shop practices and safety procedures when moving the unit.**

- Step 3)** Read the compressor nameplate to verify the model and size ordered.
- Step 4)** Read the motor nameplate to be sure the motor is compatible with your electrical conditions (volts, phase, hertz).
- Step 5)** Read the pressure relief valve nameplate to be sure it does not exceed the working pressure shown on the compressor or any other component in the system.
- Step 6)** **Read and understand the safety precautions contained within this manual.** The successful and efficient operation of compressor equipment depends largely upon the amount of care taken to install and maintain the equipment. Quincy Compressor strongly recommends that any or all person(s) in charge of installing, maintaining, or servicing one of our compressors read and understand the entire contents of this manual in order to perform such duties safely and efficiently.

### *Freight Damage*

It is extremely important that you examine every carton and crate as soon as you receive it. If there is any obvious damage to the shipping container, have the delivering carrier sign the freight bill, noting the apparent damage, and request a damage report.

**If concealed damage is discovered at a later date, the carrier must be notified within 15 days of initial receipt of freight. Concealed shipping damage is not covered by Quincy Compressor Warranty.** Contact the carrier as soon as possible, giving them an opportunity to inspect the shipment at the premises where the delivery was made. Do not move the damaged freight from the premises where the original delivery was made.

Retain all containers and packing for inspection by the carrier.

A claim form can be requested from the carrier: Standard Form for Presentation of Loss and Damage Claims (form # 3208). Your claim will need to be substantiated with the following documents:

- a.) form #3208
- b.) original bill of lading
- c.) original paid freight bill
- d.) original invoice or certified copy
- e.) other particulars obtainable in proof of loss or damage (photos, damage inspection, etc.)

The proper description and classification of our product in the National Motor Freight Classification 100-H, contained in item 118100, reads as follows: Compressors, air, or air ends: with or without air tanks, hose or nozzles, mounted or not mounted.”

We suggest that these instructions be circulated to your shipping and receiving personnel.

### ***Location***

QT & PLT Series air compressors should be installed in an area that is clean, dry, well lighted, adequately ventilated, and not more than 24 inches to a wall or other compressor. *(Note: A gas engine will produce carbon monoxide; always provide adequate ventilation!)* Inspection and maintenance checks are required daily. Therefore, sufficient space needs to be provided around the compressor for safe and proper inspection, cleaning, and maintenance.

Ample circulation of air must be provided across the compressor cylinders, heads and cooler (if so equipped). If at all possible, the pulley drive system (i.e. motor pulley, compressor sheave, belts and guard) should be located next to a wall to minimize any danger created by the drive system while the compressor is operating. Do not allow hot air from additional equipment to blow towards the compressor.

QT & PLT series compressors should be operated in temperatures under 104°F. In cold climates, the compressor should be installed in a heated building.

## **CAUTION !**

**Do not operate this compressor in ambient temperatures lower than -15° F. A crankcase heater is recommended for a compressor that is to operate in temperatures under 32° F.**

## **WARNING !**

**Under no circumstances should a compressor be used in an area that may be exposed to toxic, volatile, or corrosive atmosphere. Do not store toxic, volatile, or corrosive agents near the compressor.**

### **Noise**

Noise is a potential health hazard that must be considered. There are federal and local laws governing acceptable noise levels. Check with local officials for specifications.

Excessive noise can be effectively reduced through various methods. Total enclosures, intake silencers, baffle walls, relocating or isolating the compressor can reduce noise levels. Care must be taken when constructing total enclosures or baffle walls. If not properly constructed or positioned, they could contribute to unacceptable noise levels or overheating. Consult your local Quincy distributor if assistance is required.

## **WARNING !**

**Unusual noise or vibration indicates a problem. Do not operate the compressor until the source has been identified and corrected.**

### ***Electrical Supply Requirements***

The electrical installation of this unit should be performed by a qualified electrician with knowledge of the National Electrical Code (NEC), OSHA code and/or any local or state codes having precedence.

Before installation, the electrical supply should be checked for adequate wire size and transformer capacity. Verify that the electrical supply voltage matches the requirements of the motor. A suitable circuit breaker or fused disconnect switch should be provided. When a 3 phase motor is used to drive a compressor, any unreasonable voltage imbalance between the legs must be eliminated and any high or low voltage corrected to prevent excessive current draw. **Note: This unit must be grounded.**

The installation, electric motor, wiring, and all electrical controls must be in accordance with NFPA 70-1996 National Electric Code, National Electric Safety Code, state and local codes. Failure to abide by the national, state and local codes may result in physical harm and/or property damage.

## **DANGER !**

**High voltage may cause personal injury or death. Disconnect and lockout/tagout per OSHA regulation 1910.147 all electrical power supplies before opening the electrical enclosure or servicing.**

## **WARNING !**

**Never assume a compressor is safe to work on just because it is not operating. It could restart at any time. Follow all safety precautions outlined in SECTION 5, *Stopping For Maintenance*.**

## **WARNING !**

**Electrical enclosures and components must be in compliance with NEMA environmental ratings for the areas in which they are being installed.**

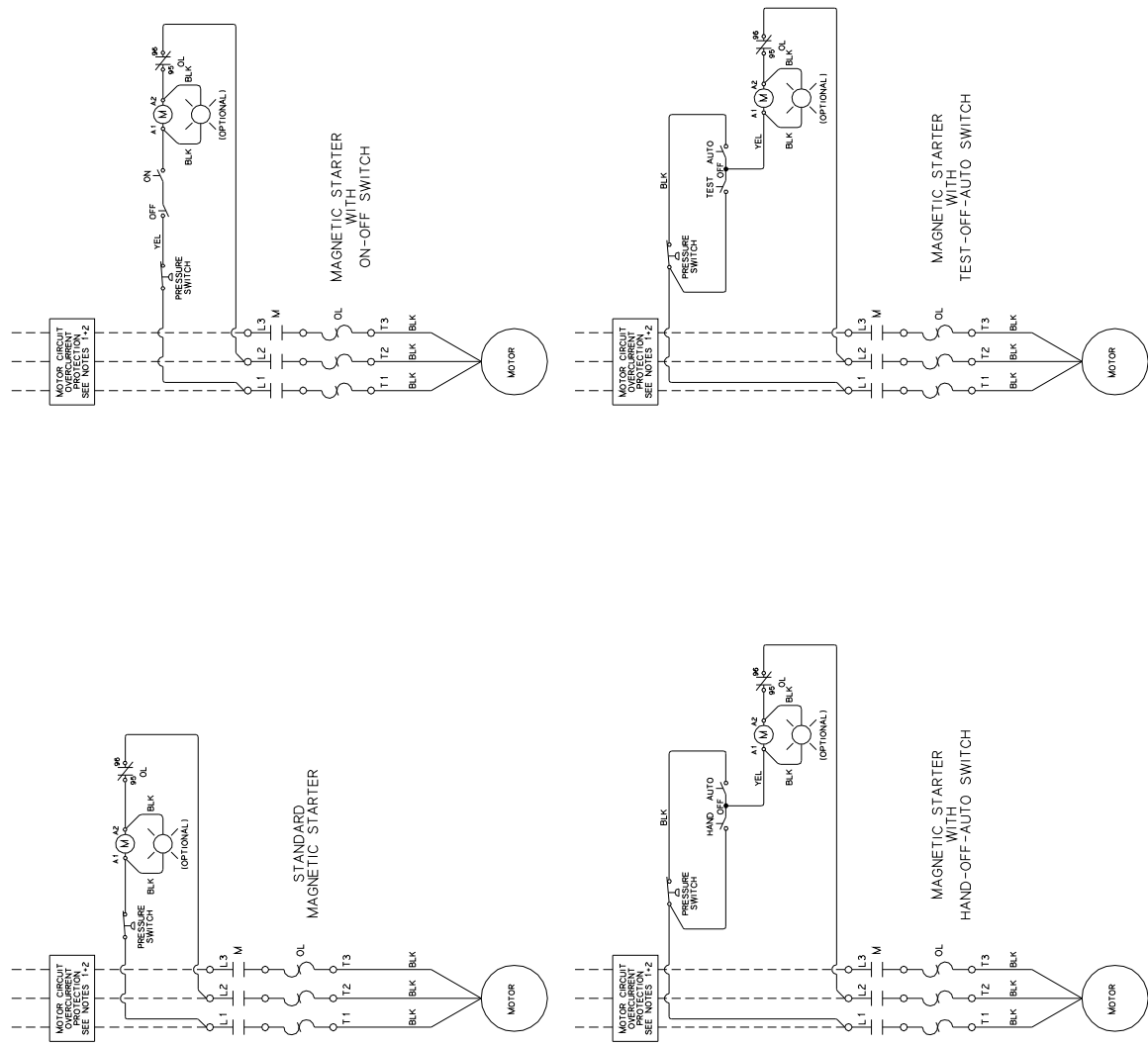
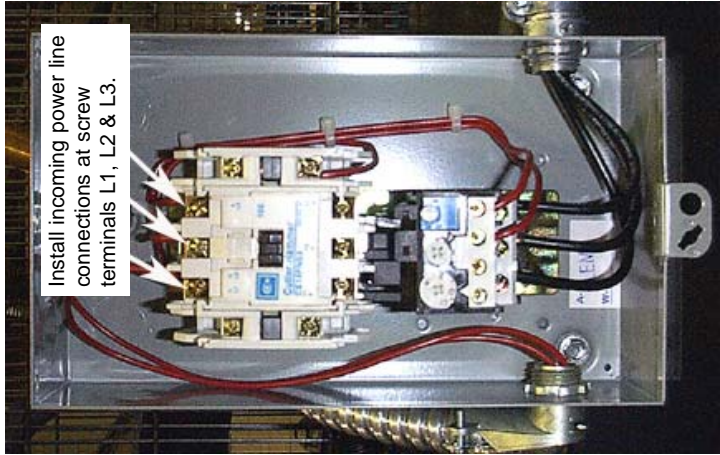

**Fig. 3-1**  
**3 Phase Start / Stop Control**  
**Wiring Schematic WP1744A (Rev. D)**

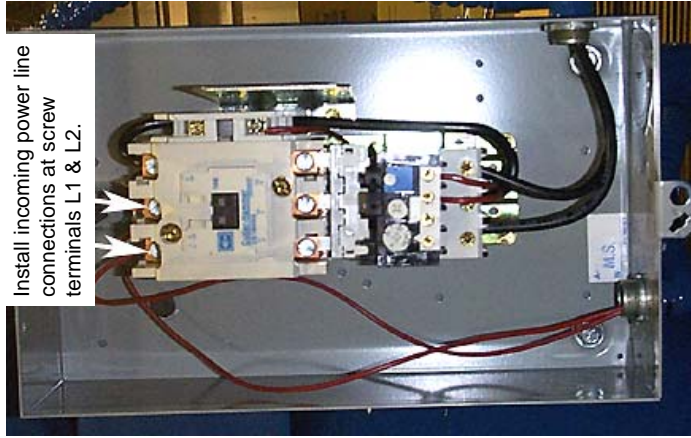
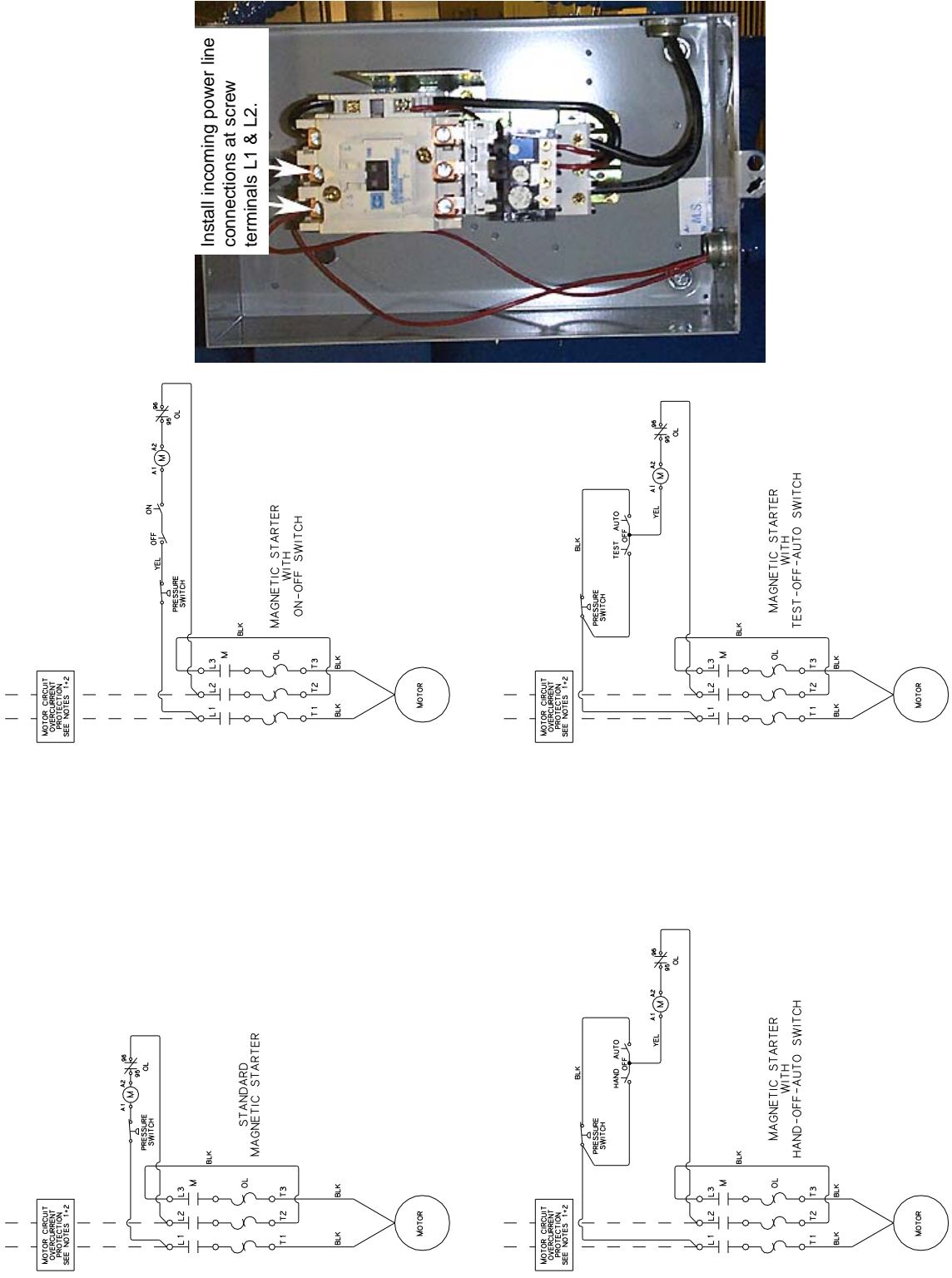

**Fig. 3-2**  
**Single Phase Start / Stop Control**  
**Wiring Schematic WP1744B (Rev. D)**





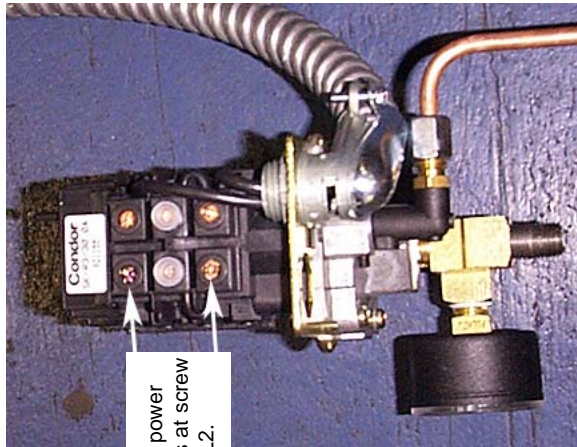

Install incoming power line connections at screw terminals L1 & L2.

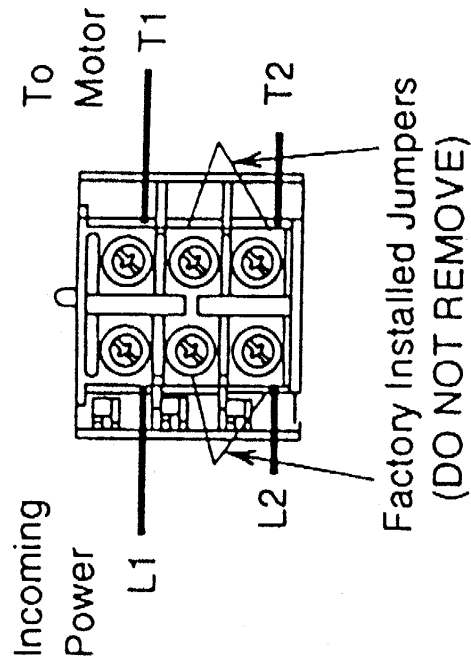

**Fig. 3-4**  
**Single Phase MDR Pressure Switch / Overload Relay**  
**Connection Diagram**  
**(Rated 22-30 Amps)**

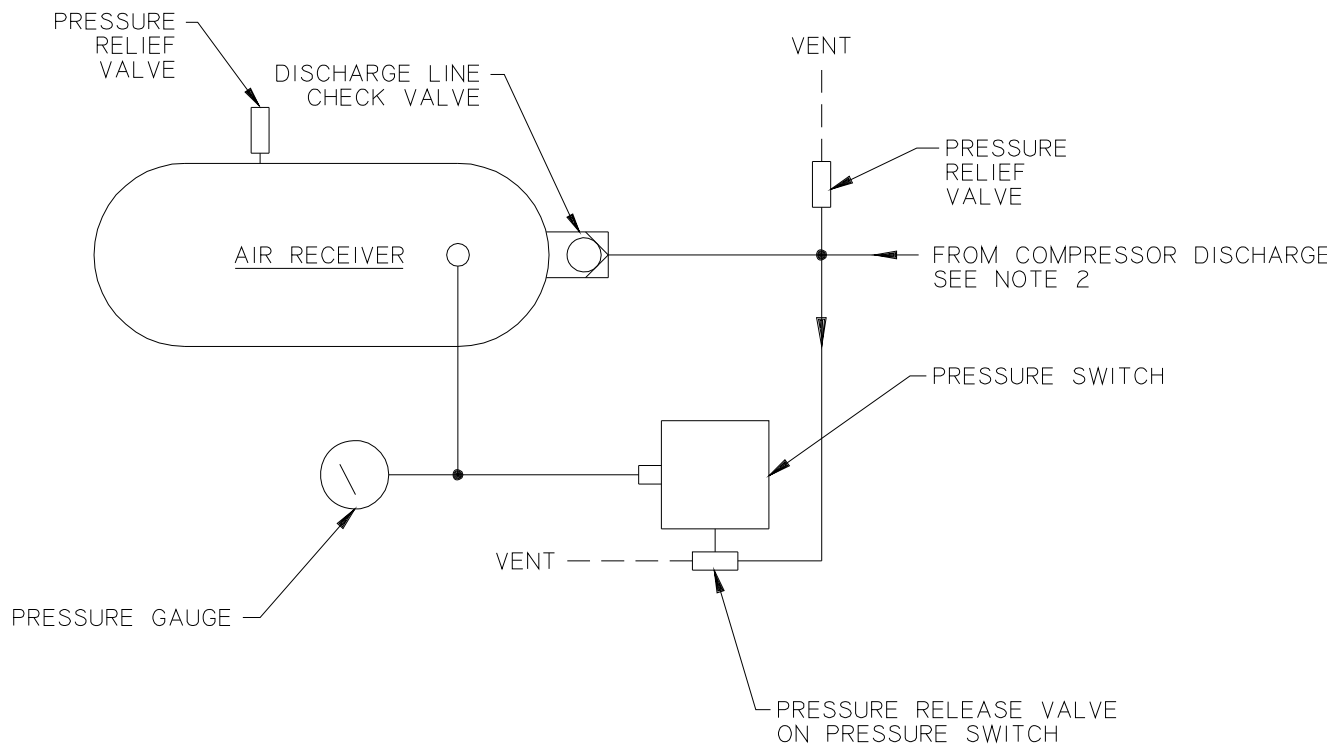

NOTE:

- 1) INSTALL PRESSURE RELIEF VALVE SO THAT MOISTURE CAN NOT ACCUMULATE IN VALVE INLET.
- 2) USE FLEXIBLE LINE BETWEEN REMOTE RECEIVER AND COMPRESSOR TO REDUCE STRAIN ON PIPING.

**Fig. 3-4**  
**Start / Stop Control**  
**Piping Schematic WP1781B**

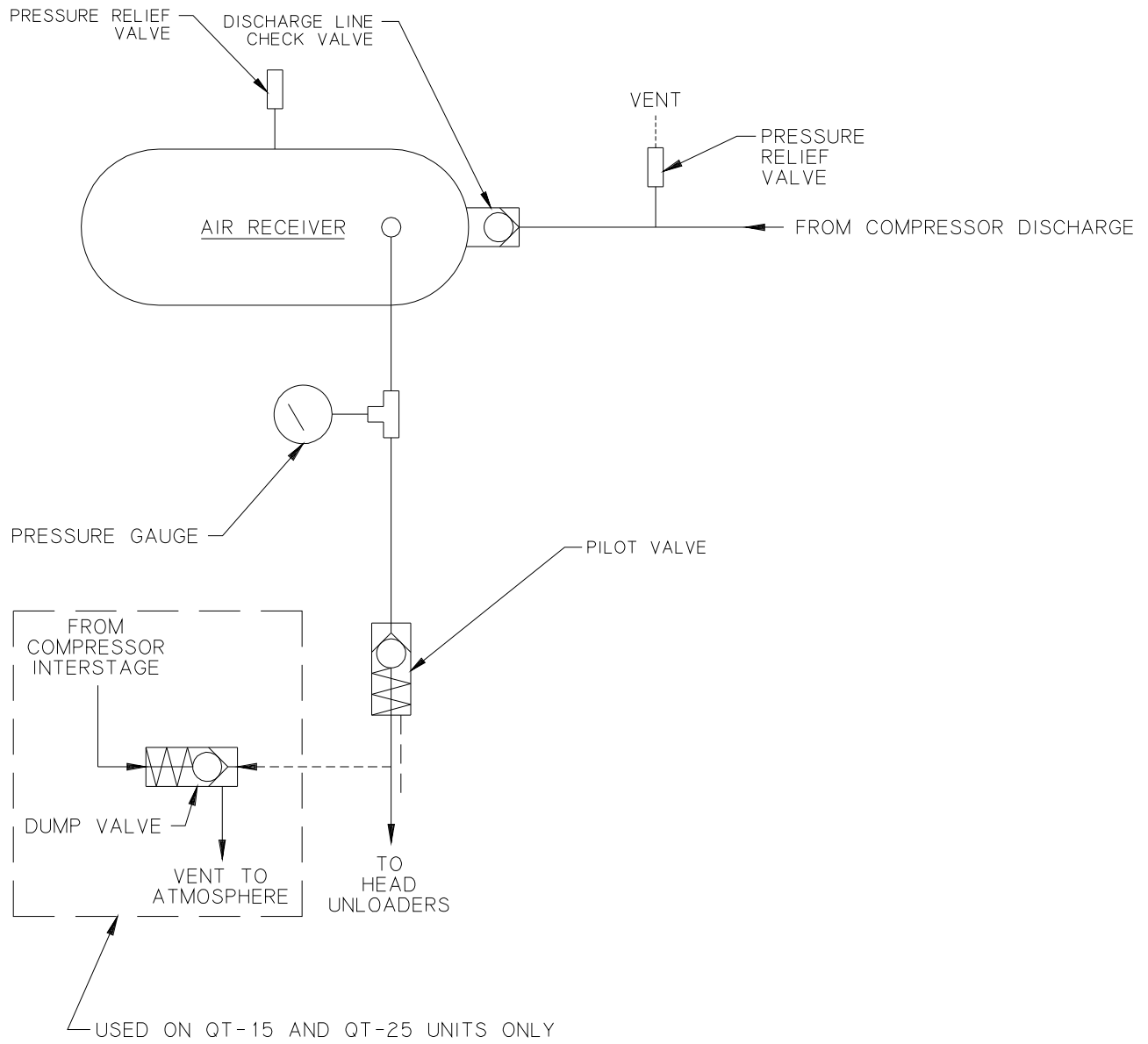

**Fig. 3-5**  
**Continuous Run - Load / Unload Control**  
**Piping Schematic WP1781C**

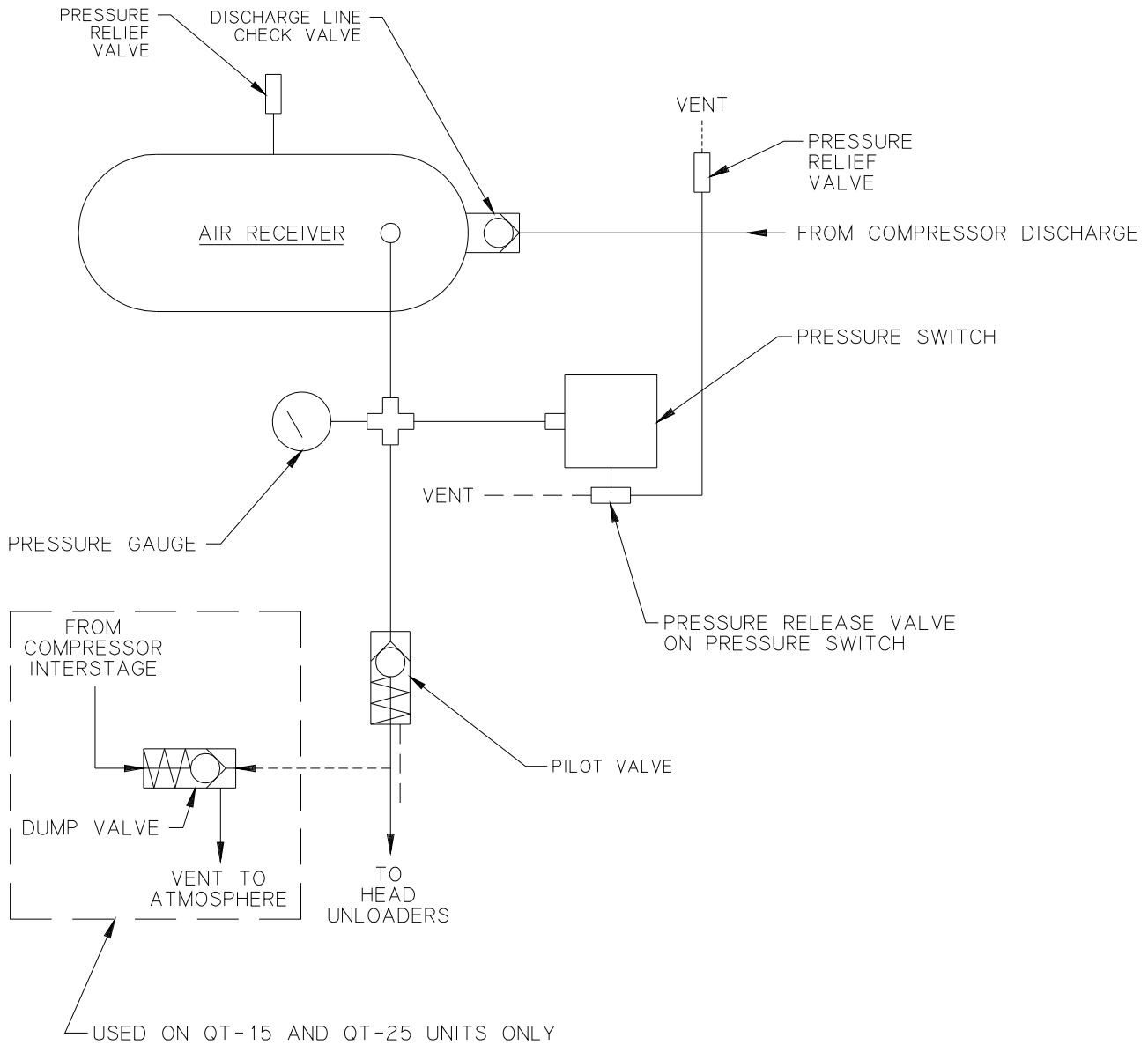

**Fig. 3-6**  
**Dual Control with Pilot Valve Unloading**  
**Piping Schematic WP1781A**

## Mounting

Proper mounting of QT & PLT series compressor units is crucial to the safe operation and longevity of the equipment. The installation requires a flat and level concrete floor or pad (*for mobile units see **Mounting Mobile Units***). Satisfactory results can usually be obtained by mounting the compressor unit on vibration isolating pads available from your local Quincy distributor. **All vertical tank units must be anchored!** Refer to **Fig. 3-7, Isolator Installation for Unanchored or Anchored Receiver.**

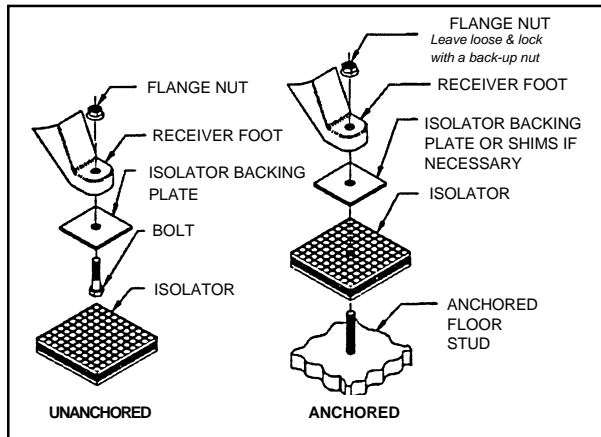

**Fig. 3-7 Isolator Installation for Unanchored or Anchored Receiver**

**All vertical tank units must be anchored!** Refer to **Fig. 3-7, Isolator Installation for Unanchored or Anchored Receiver.**

State or local codes may mandate that the compressor be bolted to the floor. In this case the unit must be leveled and bolted making absolutely certain the feet are not stressed in any manner. **Leave the flange nut loose & lock it with a back-up nut!** Uneven feet drawn tightly to the concrete pad will cause severe vibrations resulting in cracked welds or fatigue failure. The customer is responsible for providing a suitable foundation & isolator mounting where necessary.

### Mounting Mobile Units

Gas engine driven compressors mounted to truck beds should be fastened in such a way so as not to create any stress to the air receiver tank. Truck beds, characteristically, have a tendency to flex and could cause damage to the receiver tank if the tank is fastened directly to the truck bed. It is the user's responsibility to provide an adequate means of fastening the unit in these applications.

## CAUTION !

**Do not operate this compressor more than 15° off level or move it while it is operating.**

### System components

Efficiency and safety are the primary concerns when selecting components for compressed air systems. Products of inferior quality can not only hinder performance of the unit, but could cause system failures that result in bodily harm or even death. Select only top quality components for your system. Call your local Quincy distributor for quality parts and professional advice.

### Drive Pulleys / Sheaves

Various pulley and sheave combinations are available to obtain the desired air pressure and delivery rate of your compressor. Consideration must be given to these combinations to ensure that the motor is not overloaded by operating above or below the designed speed range.

Whatever combination is employed, the drive pulleys & compressor sheaves must be properly aligned and drive belt tension set to specifications (refer to **SECTION 5, Pulley / Sheave Alignment & Belt Tension**). Improper pulley/sheave alignment and belt tension can cause motor overloading, excessive vibration, and premature belt and/or bearing failure.

# WARNING !

**Excessive compressor RPM's (speed) could cause a pulley or sheave to shatter. In an instant, the pulley or sheave could separate into fragments capable of penetrating the belt guard and causing bodily harm or death. Do not operate the compressor above the recommended RPM (refer to SECTION 2, *Specifications*).**

## Guards

All mechanical action or motion is hazardous in varying degrees and needs to be guarded. Guards should be designed to achieve the required degree of protection and still allow full air flow from the compressor sheave across the unit. Guards shall be in compliance with OSHA safety and health standards 29 CFR 1910.219 in OSHA manual 2206 and any state or local codes.

# WARNING !

**Guards must be fastened in place before starting the compressor and never removed before cutting off and locking out the main power supply.**

## Check Valves

Check valves are designed to prevent back-flow of air pressure in the compressed air system (air flows freely in one direction only). The check valve must be properly sized for air flow and temperature. **Do not rely upon a check valve to isolate a compressor from a pressurized tank or compressed air delivery system during maintenance procedures!**

## Manual Shutoff Valves

Manual shutoff valves block the flow of air pressure in either direction. This type of valve can be used to isolate a compressor from a pressurized system, provided the system is equipped with a pressure relief valve capable of being manually released. The pressure relief valve should be installed between the manual shutoff valve and the compressor (refer to **Fig. 3-8, Typical Drop Leg & Component Location**).

## Pressure Relief Valves

Pressure relief valves aid in preventing system failures by relieving system pressure when compressed air reaches a determined level. They are available in various pressure settings to accommodate a range of applications. Pressure relief valves are preset by the manufacturer and under no circumstances should the setting be changed by anyone other than the manufacturer.

# DANGER !

**Pressure relief valves are designed to protect compressed air systems in accordance with ASME B19 safety standards. Failure to provide properly sized pressure relief valves may cause property damage, severe personal injury or even death.**

## Pressure Switch

The pressure switch detects the demand for compressed air and allows the motor to start. When the demand is satisfied, the unit stops. Pressure switches provided by Quincy Compressor are pre-set at the factory and usually do not require adjustment.

## ***Induction System***

### **Air Intake**

A clean, cool and dry air supply is essential to the satisfactory operation of your Quincy QT or PLT Series air compressor. The standard air filter that the compressor is equipped with when leaving the factory is of sufficient size and design to meet normal conditions, when properly serviced, in accordance with the maintenance section of this manual.

If, however, the compressor is to be installed in a location where considerable dust, dirt and other contaminants are prevalent, consult your local Quincy distributor for advice and optional filters. A condensate trap must be installed as close as possible to the inlet filter if, as a result of installation or environmental conditions, there is any risk of moisture forming in the inlet piping. It is the user's responsibility to provide adequate filtration for those conditions. Oil bath filters are not to be used. Warranty will be void if a failure is determined to be caused by inadequate filtration.

### **Remote Inlet Filters**

Depending on the size of the compressor and the size and construction of the room in which the unit operates, the air inlet may have to be located outside of the room. If it is necessary to remotely install the air filter, make the inlet piping as short and direct as possible. Remotely installed air filters can lead to vibrations in the inlet piping. These vibrations can be minimized by adding a pulsation dampener in the inlet piping between the remote inlet filter(s) and the compressor.

If the inlet is routed to outside atmosphere, the inlet piping should be equipped with a hooded air filter and designed to prevent condensate, water or snow from being injected into the compressor.

All inlet piping should be at least the same size (or larger) in diameter as the inlet connection to the compressor. For every 10 feet of inlet piping or every 90° bend, increase the inlet piping diameter by one pipe size. The inlet piping must be thoroughly clean inside. Remove all weld slag, rust or dirt. Galvanized pipe with threaded or flanged fittings is preferred.

## **CAUTION !**

**Never locate the compressor air inlet system where toxic, volatile or corrosive vapors, air temperatures exceeding 100°F, water, or extremely dirty air could be ingested. These types of atmospheres could adversely affect the performance of the compressor system.**

## ***Compressed Air Discharge System***

The discharge piping should be of the same diameter as the compressor discharge connection, or sized so that the pressure drop at any point in the system does not exceed 10% of the air receiver pressure. Install auxiliary air receivers near heavy loads or at the far end of a long system. This will insure sufficient pressure if the use is intermittent, or sudden large demands are placed on the system.

Discharge piping should slope to a drop leg (refer to **Fig. 3-8, Typical Drop Leg & Component Location**) or moisture trap to provide a collection point

where moisture can be easily removed. All service line outlets should be installed above the moisture traps to prevent moisture from entering the tool or device using the air. Manual shutoff valves, protected by pressure relief valves, should be installed at all service line outlets to eliminate leakage while the tools are not in use.

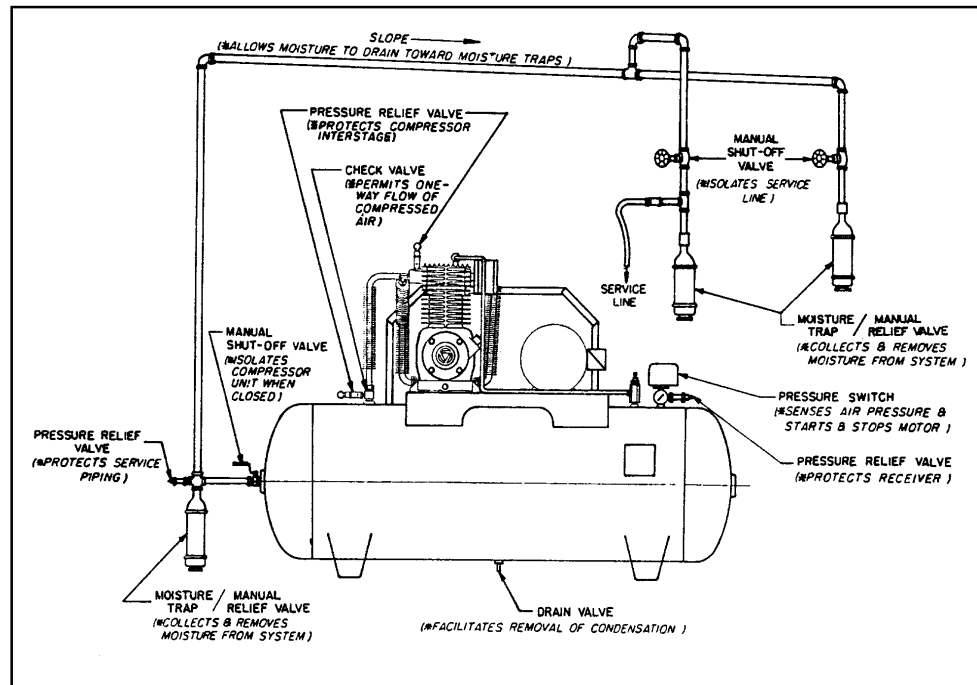

**Fig. 3-8 Typical Drop Leg & Component Location**

Pix 1007-004

As with any piping, all parts of the discharge piping should fit so as not to create any stress between the piping and components.

### **Pneumatic Circuit Breakers or Velocity Fuses**

The Occupational Safety and Health Act (OSHA), Section 1926.303, Paragraph 7, published in the Code of Federal Regulations 29 CFR 1920.1, revised July 1, 1982 states that all hoses exceeding 1/2" inside diameter shall have a safety device at the source of supply or branch line to reduce pressure in case of a hose failure"

These pneumatic safety devices are designed to prevent hoses from whipping and/or the loss of hazardous or toxic gasses, all of which could result in a serious or fatal accident.

## **WARNING !**

**Never join pipes or fittings with lead-tin soldering. Welded or threaded steel pipes and cast iron fittings, designed for the pressures and temperatures, are recommended.**

### **Pressure Vessels**

Air receiver tanks and other pressure containing vessels such as (*but not limited to*) pulsation bottles, heat exchangers, moisture separators and traps, must be in accordance with ASME Boiler and Pressure Vessel Code Section VIII and ANSI B19.3 safety standards. They must be equipped with a properly sized



pressure relief valve, pressure gauge, tank drain, & manual shutoff valve (refer to **Fig. 3-8, Typical Drop Leg & Component Location**).

## WARNING !

**Follow ASME code for air receiver tanks and other pressure containing vessels. Pressure vessels must not be modified, welded, repaired, reworked or subjected to operating conditions outside the nameplate ratings. Such actions will negate code status, affect insurance status and may cause property damage, severe injury or even death.**

A drain valve should be located in the bottom of the air receiver to allow for moisture drainage. An automatic drain valve is recommended. Extend piping away from the unit and any personnel in the immediate area to provide safe and convenient removal of excess moisture.

If the air receiver is going to be subject to temperatures of 32°F or below, provisions must be made to guard against freezing of the pressure relief valves, check valves, pressure gauge, and moisture drain.

### Condensation

Rust can form inside the crankcase and on internal components as a result of condensation. A compressor must operate long enough during each run cycle to reach full operating temperature in order to reduce the risk of condensation.

## CAUTION !

**Lubricant that appears milky on the dipstick may have mixed with condensate. Failure to replace contaminated lubricant will result in damage to the compressor and may void warranty.**

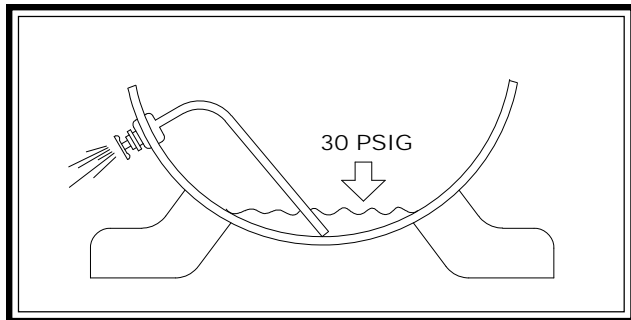

**Fig. 3-9 Internal Drain Tube**

Pix 1224

Condensation can also form in the air tank of your compressor. When this happens, a mixture of air and moisture will be expelled through the service valve and into whatever is connected to the valve (e.g. air hoses, metal air lines, pneumatic tools, spray guns). An in-line filter or dryer, available from your local Quincy distributor, may be required to eliminate the moisture.

Condensation in the air tank can be kept to a minimum by draining the tank on a daily basis. This also reduces the risk of rust developing and weakening the tank.

### Manual Tank Drain Valve Operation

The manual tank drain valve on portable compressors and some stationary compressors is located on the underside of the air tank. Portable compressors can be tilted in the direction of the drain to allow removal of tank moisture.

Some tanks use an internal drain tube (Refer to **Fig. 3-9, Internal Drain Tube**) to drain the moisture. Tank pressure is required to force moisture out of the tank through the drain tube. Safe removal of tank moisture from the air tank is dependent upon an internal tank pressure of no more than 30 PSIG. Higher internal tank pressures are dangerous and could cause serious injury!

# WARNING !

Do not open a manual tank drain valve on any air tank containing more than 30 PSIG of air pressure!

# WARNING !

Never attempt to relieve an air tank by removing a pipe plug or any other system component!

### *Manually Draining An Air Tank:*

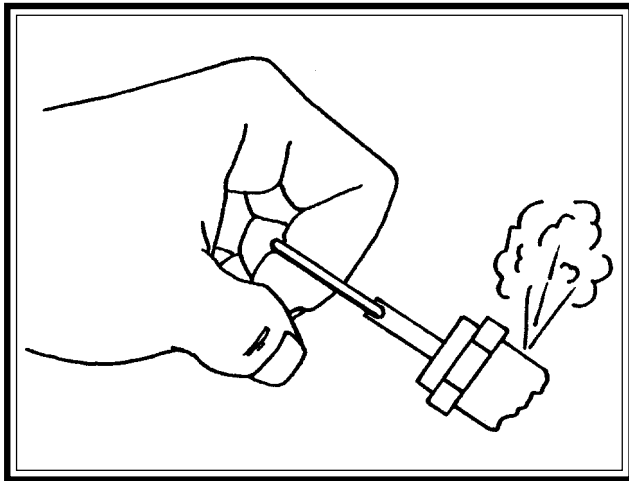

**Fig. 3-10 Checking Pressure Relief Valves & Relieving System Pressure** Pix 1160

**Step 1)** Disconnect & lockout the compressor from the power source (electric models) or disconnect the spark plug wire from the spark plug (gas engine models).

**Step 2)** Tanks subjected to freezing temperatures may contain ice. Store the compressor in a heated area before attempting to drain moisture from the tanks. Reduce the air pressure in the tank to 30 PSIG by pulling the pressure relief valve ring (refer to **Fig. 3-10, Checking Pressure Relief Valves & Relieving System Pressure**).

**Step 3)** Open the drain valve and allow the moisture and air mixture to drain from the tank.

**Step 4)** Once the moisture has been completely drained, close the drain valve.

*Pre-starting Checklist***WARNING !**

Never assume a compressor is safe to work on just because it is not operating. It could restart at any time. Follow all safety precautions outlined in SECTION 5, *Stopping For Maintenance*.

**WARNING !**

Failure to perform the pre-starting checklist may result in mechanical failure, property damage, serious injury or even death.

Steps 1 through 12 should be performed prior to connecting the unit to a power source. If any condition of the checklist is not satisfied, make the necessary adjustments or corrections before starting the compressor.

- Step 1)** Remove all installation tools from the compressor and check for installation debris.
- Step 2)** Unless otherwise specified, Quincy QT & PLT Series compressors are normally shipped with break-in lubricant in the crankcase. **Check the lubricant level in the crankcase.** (Refer to **SECTION 5, Lubrication** for quantity and types of lubricant to be used.)
- Step 3)** Check motor pulley and compressor sheaves for alignment and tightness on shaft. (Refer to **SECTION 5, Pulley / Sheave Alignment & Belt Tension**.)
- Step 4)** Manually rotate the compressor sheave several rotations to be sure there are no mechanical interferences.
- Step 5)** Check inlet piping installation (Refer to **SECTION 3, Induction System**.)
- Step 6)** Check belt tension. (Refer to **SECTION 5, Pulley / Sheave Alignment & Belt Tension**.)
- Step 7)** Check all pressure connections for tightness.
- Step 8)** Make sure all pressure relief valves are correctly installed. (Refer to **SECTION 3, System Components**.)
- Step 9)** Be sure all guards are in place and securely mounted. (Refer to **SECTION 3, System Components**.)
- Step 10)** Check fuses, circuit breakers, and thermal overloads for proper size. Verify that the supply voltage matches the motor requirements. (Refer to **SECTION 3, Electrical Supply Requirements**.)
- Step 11)** Open all manual shutoff valves at and beyond the compressor discharge.

- Step 12)** After all the above conditions have been satisfied, the unit can be connected to the proper power source.
- Step 13)** Jog the starter switch to check the rotational direction of the compressor. It should agree with the rotation arrow embossed on the compressor sheave.
- Step 14)** Check for proper rotation of the cylinder cooling fan (fins inside sheave). The fan should blow cooling air across the cylinder.

### ***Initial Starting & Operating***

This instruction manual, as well as any instructions supplied by manufacturers of supporting equipment, should be read and understood prior to starting the compressor. If there are any questions regarding any part of the instructions, please call your local Quincy distributor, or the Quincy Compressor factory.

With the pre-starting checklist completed and satisfied, start the compressor. Watch and listen for excessive vibration and strange noises. If either exist, stop the compressor. Refer to **SECTION 6, Troubleshooting** for help in determining the cause of such problems.

If you are starting a pressure lubricated model, check the oil pressure. Compressors producing up to 175 PSIG of discharge air pressure should maintain 18 to 20 PSIG of oil pressure.

Normally the oil pressure does not need to be adjusted. But if it does, loosen the locknut on the adjustment screw located on the right side of the oil pump housing (see **Fig. 4-1, Oil Pressure Adjustment**). Increase the oil pressure by turning the adjustment screw clockwise; decrease the oil pressure by turning the adjusting screw counterclockwise. After adjustment tighten the locknut.

Check the air receiver pressure gauge or system pressure gauge for proper readings. If inadequate or excessive air pressure conditions exist, refer to **Section 6 Troubleshooting**.

Observe compressor operation closely for the first hour of operation and then frequently for the next seven hours. After the first eight hours, monitor the compressor at least once every eight hours. If any abnormal conditions are witnessed, stop the compressor and correct the problem. After two days of operation check belt tension, lubricant level, and inspect the system for leaks.

A new or rebuilt reciprocating compressor should be run for a total of 100 hours at full discharge operating pressure to break-in the new piston rings. Until the rings are seated, the compressor will discharge higher than normal amounts of lubricant. In light of this fact, the lubricant level should be checked more frequently during the 100 hour break-in period.

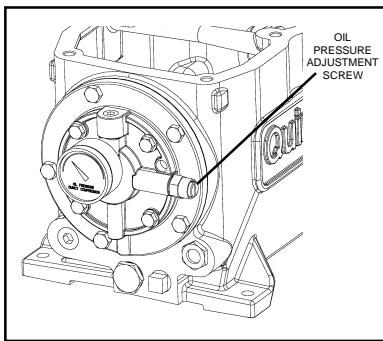

PIX 1220

**Fig. 4-1**  
**Oil Pressure Adjustment**

## Daily Starting Checklist

Do not proceed until the **Pre-starting Checklist** and **Initial Starting & Operating** sub-sections have been read and are thoroughly understood.

- Step 1)** Check lubricant level in crankcase.
- Step 2)** Drain liquid from the air receiver and moisture trap (if so equipped).
- Step 3)** Jog the starter button and check compressor rotation.

*Note: Continuous Run Units - Prior to starting a continuous run unit, flip the toggle lever on the pilot valve stem to the "Manual Unload" position (see below). Now the compressor can be started unloaded. Once the compressor is running at full speed, flip the toggle lever back to the "RUN" position.*

- Step 4)** Start compressor per factory instructions. (Refer to **SECTION 4, Pre-Starting Checklist and Initial Starting & Operating.**)
- Step 5)** Check system pressure.
- Step 6)** Check cooling fan.
- Step 7)** Check all pressure relief valves for proper operation.
- Step 8)** Check control system for proper operation.

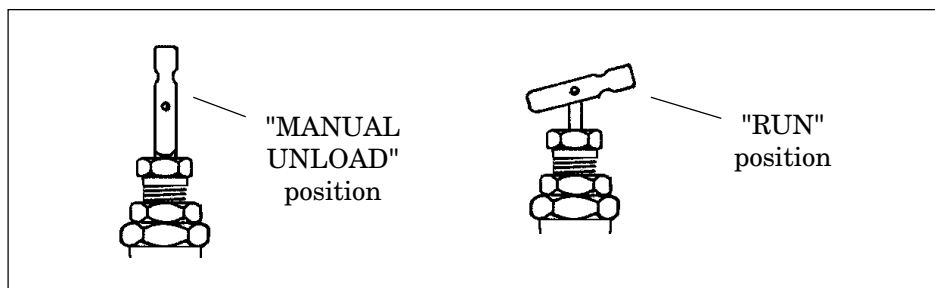

**Fig. 4-2**  
**Continuous Run Pilot Valve**

- Step 9)** Check the lubricant level in the crankcase several minutes after the compressor has run. (Discoloration or a higher lubricant level reading may indicate the presence of condensed liquids.) If lubricant is contaminated, drain and replace.

## SECTION 5

## MAINTENANCE & LUBRICATION

### *Stopping for Maintenance*

The following procedures should be followed when stopping the compressor for maintenance or service:

**Step 1)** Per OSHA regulation 1910.147: The Control of Hazardous Energy Source (Lockout/Tagout), disconnect and lockout the main power source. Display a sign in clear view at the main power switch stating that the compressor is being serviced.

## **WARNING !**

**Never assume a compressor is safe to work on just because it is not operating. It could restart at any time.**

**Step 2)** Isolate the compressor from the compressed air supply by closing a manual shutoff valve upstream and downstream from the compressor. Display a sign in clear view at the shutoff valve stating that the compressor is being serviced.

**Step 3)** Lock open a pressure relief valve within the pressurized system to allow the system to be completely de-pressurized. **NEVER** remove a plug to relieve the pressure!

**Step 4)** Open all manual drain valves within the area to be serviced.

**Step 5)** Wait for the unit to cool before starting to service. (Temperatures of 125°F can burn skin. Some surface temperatures exceed 350°F when the compressor is operating.)

### *Maintenance Schedule*

To assure maximum performance and service life of your compressor, a routine maintenance schedule should be developed. A sample schedule has been included here to help you to develop a maintenance schedule designed for your particular application. Time frames may need to be shortened in harsher environments.

At the back of this instruction manual you will find a **Maintenance Schedule Checklist**. Make copies of this checklist and retain the master to make more copies as needed. On a copy of the checklist, enter dates and initials in the appropriate spaces. Keep the checklist and this Instruction Manual readily available near the compressor.

### *Maintenance Schedule Checklist Sample*

#### *Every 8 Hours (or Daily)*

- QT-5, PLT-5, QT-7.5, PLT-7.5, QT-10 & PLT-15 lubricant levels should be kept at the top of the sight glass (add lubricant until it reaches the bottom edge of the lubricant fill opening).
- Maintain lubricant levels of QT-15, QT-25 & QT-54 models between high and low level marks on dipstick. Check the lubricant level several minutes after the compressor has run. (Discoloration or a higher lubricant level reading may indicate the presence of condensed liq-

Quincy Compressor

uids.) If lubricant is contaminated, drain and replace.

- Drain receiver tank, drop legs and traps in air distribution system. Receiver tanks subjected to freezing temperatures may contain ice. Store the compressor unit in a heated area before attempting to drain moisture from the tank.
- Give compressor an overall visual inspection and be sure safety guards are in place.
- Check for any unusual noise or vibration.
- Check for lubricant leaks.
- Check all pressurized components for rust, cracks or leaks. Immediately discontinue use of the equipment and relieve all system pressure if any of these problems are discovered. Do not use the equipment until it has been inspected and repaired by a qualified mechanic.

#### ***Every 40 Hours (or Weekly)***

- Manually operate the pressure relief valves to be certain they are working.
- Clean the cooling surfaces of the intercooler, aftercooler and compressor.
- Check the compressor for air leaks.
- Check the compressed air distribution system for leaks.
- Inspect lubricant for contamination & change if necessary.
- Clean or replace the air intake filter. Check more often under humid or dirty conditions.

#### ***Every 160 Hours (or Monthly)***

- Check belt tension

#### ***Every 500 Hours (or Every 3 Months)***

- Change lubricant (more frequently in harsher environments).
- Torque pulley clamp screws or jamnut.

#### ***Every 1000 Hours (or Every 6 Months)***

- When Quin-Cip lubricant is used, lubricant change intervals may be extended to every 1000 hours or every 6 months, whichever occurs first (change more frequently in harsher conditions).
- Inspect compressor valves for leakage and/or carbon build-up. If excessive sludge build-up exists inside the crankcase, clean the inside of the crankcase as well as the screen. **Never use a flammable or toxic solvent for cleaning. Always use a safety solvent and follow the directions provided.**

#### ***Every 2000 Hours (or Every 12 Months)***

- Inspect the pressure switch diaphragm and contacts. Inspect the contact points in the motor / starter.

### **Servicing Reed Valves**

QT & PLT Series compressor valve plates and reed valves should be inspected and cleaned on a regular basis. The reed valves are made of stainless steel and can be cleaned with a stiff bristle brush (*not a wire brush!*). A clean safety solvent may also be used to loosen carbon deposits on the valve plates and reed valves. Handle all parts with care; do not bend, mar or scratch any sealing surfaces.

# **DANGER !**

**Never use gasoline, thinners, or other flammable solutions to clean valves or related parts.**

## ***Lubrication***

**QT and PLT Series basic compressors and units are normally shipped from the factory *with* break-in lubricant in the crankcase.** Before starting your compressor, check the lubricant level in the crankcase. The lubricant level of QT-5, PLT-5, QT-7.5, PLT-7.5, QT-10 & PLT-15 compressors must reach the bottom edge of the lubricant fill opening. The lubricant level of QT-15, QT-25 & QT-54 compressors must register between the high and low marks on the dipstick. **Replace the break-in lubricant after 100 hours of operation with *Quin-Cip* lubricant!**

*Quin-Cip* lubricant has proven under extensive testing to minimize friction and wear, limit lubricant carryover, and reduce carbon and varnish deposits. It will support the performance characteristics and life designed into all Quincy compressors and is highly recommended. Refer to the charts below to determine the correct amount of lubricant and viscosity to use for your model and application.

### **Approximate Crankcase Lubricant Capacities**

<b>Basic Compressor Model</b>	<b>Lubricant Capacity</b>
QT-5 & PLT-5	1 <sup>5</sup> / <sub>8</sub> qts. (1.5 lit.)
QT-7.5 & PLT-7.5	1 <sup>5</sup> / <sub>8</sub> qts. (1.5 lit.)
QT-10	1 <sup>7</sup> / <sub>8</sub> qts. (1.8 lit.)
QT-15 & PLT-15	4 <sup>3</sup> / <sub>4</sub> qts. (4.5 lit.)
QT-54	1 <sup>1</sup> / <sub>4</sub> qts. (1.15 lit.)

### **Lubricant Specifications**

(Use *Quin-Cip* lubricant or consult factory.)

<b>Ambient Temperature</b>	<b>SAE Viscosity</b>	<b>ISO Viscosity</b>
Below 0°F	SAE 5W	ISO 22
0-32° F	SAE 10W	ISO 32
32-80°F	SAE 20W	ISO 68
60-104°F	SAE 30	ISO 100

**CAUTION !**

**The lubricant selected must have a pour point at least 15° F lower than the minimum expected ambient temperature .**

**CAUTION !**

**Do not operate this compressor in ambient temperatures lower than -15° F. A crankcase heater is recommended for compressors operating in temperatures under 32° F.**



## ***Pulley / Sheave Alignment & Belt Tension***

Improper pulley/sheave alignment and belt tension are causes for motor overloading, excessive vibration, and premature belt and/or bearing failure. To prevent this from happening, check the pulley/sheave alignment and belt tension on a regular basis (refer to **SECTION 5, Maintenance Schedule**).

Periodically inspect the motor pulley(s) and compressor sheave(s) for oil, grease, nicks or burrs. Clean or replace if necessary. Make sure they are securely fastened. Align the compressor sheave with the motor or engine pulley. Drive belt grooves of the pulley(s) and sheave(s) should be in line with each other. The compressor crankshaft must be parallel to the motor or engine drive shaft.

Belt tension should be measured and adjusted to provide smooth operation. Step-by-step procedures are provided here to correctly measure and set the drive belt tension:

**Step 1)** Measure the span length of the drive. (Refer to **Fig. 5-1, Setting Belt Tension**.)

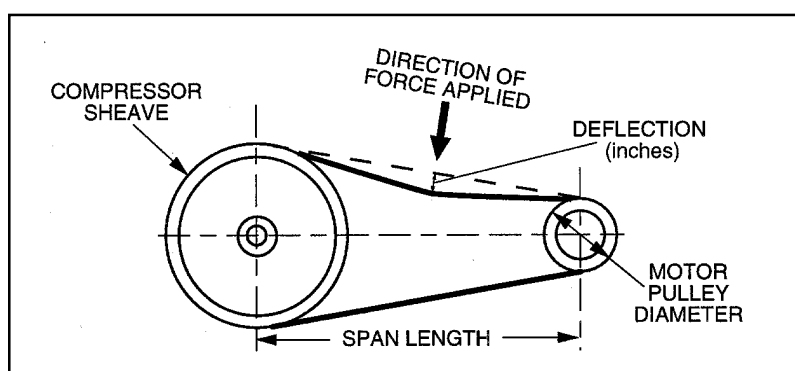

**Fig. 5-1**  
**Setting Belt Tension**

Pix 1152

<b>Belt Cross Section</b>	<b>Motor Pulley Dia. Range (inches)</b>	<b>Recommended Deflection Force (lbs.)</b>	
		<b>Minimum</b>	<b>Maximum</b>
A	QT-54 only	2	3
B	4.6	4.0	5.9
B	5.0 - 5.4	4.5	6.7
B	5.6 - 6.4	5.0	7.4
B	6.8 - 9.4	5.8	8.6

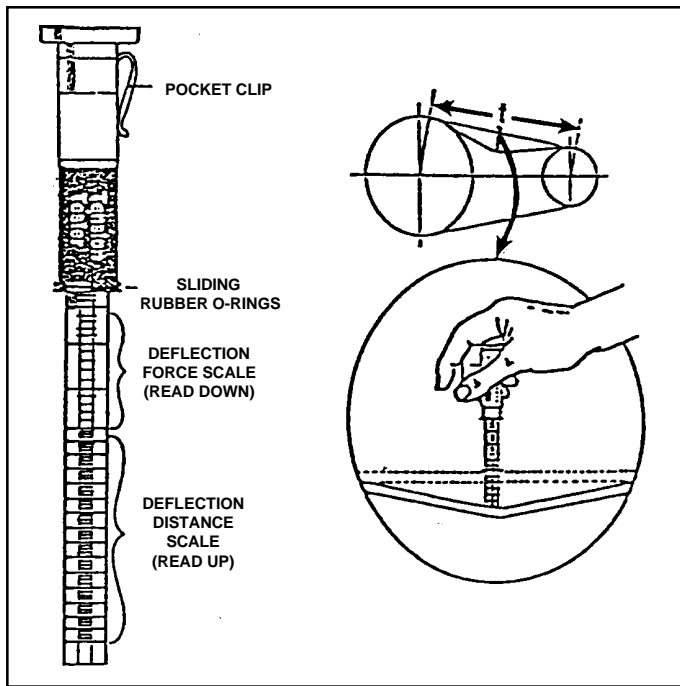

**Fig. 5-2 Belt Tension Gauge**

Pix 1153

**Step 2)** Determine the amount of deflection (in inches) required to measure deflection force (in pounds) by multiplying the span length  $\times \frac{1}{64}$  (.016) (i.e. 32" span length  $\times \frac{1}{64}$  [.016] =  $\frac{1}{2}$ " [.50] of deflection required to measure deflection force).

**Step 3)** Lay a straightedge across the top outer surface of a drive belt from pulley to sheave.

**Step 4)** At the center of the span, perpendicular to the belt, apply pressure to the outer surface of the belt with a belt tension gauge (refer to **Fig. 5-2, Belt Tension Gauge**). Force the belt to the predetermined deflection (refer to **Step 2** above). Record the reading on the belt tension gauge and compare to the chart following **Fig 5-1**. The deflection force reading should be within the minimum and maximum values shown. Adjust belt(s) accordingly. New belts should be initially tensioned to the maximum value plus 33% (multiply by 1.33).

**Step 5)** Recheck the tension of the new belts several times in the first 50 hours of operation and adjust if necessary. Thereafter, check belt tension on a regular basis (refer to **SECTION 5, Maintenance Schedule**).

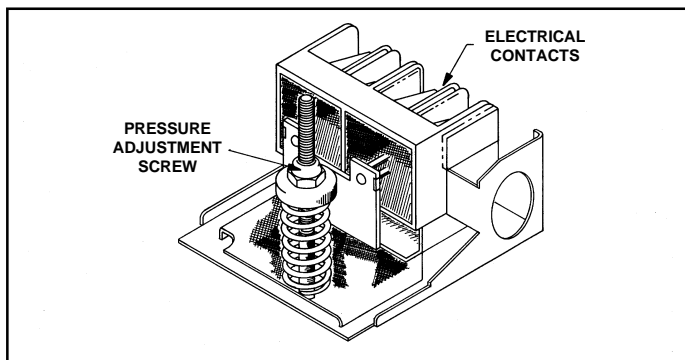

**Fig. 5-3 Pressure Switch**

Pix 1067

### ***Pressure Switch Adjustment***

Pressure switches provided by Quincy Compressor are pre-set at the factory and usually do not require adjustment. However, the following procedures can be performed by a qualified electrician to adjust the pressure switch.

**Step 1)** Remove the pressure switch cover.

**Step 2)** While the compressor is running, screw the spring loaded adjustment screw in (clockwise) to increase the amount of air pressure required to open the switch and stop the unit. Screw the spring loaded adjustment screw out (counterclockwise) to decrease the amount of air pressure required to open the switch and stop the unit.

Standard pressure switches supplied by Quincy Compressor are equipped with a fixed 20 PSIG (approx.) differential. Optional switches include both pressure and differential adjustment capabilities.

## **WARNING !**

**Electric power always exists inside the pressure switch whenever the compressor package is connected to a power supply. Be careful not to touch any electrical leads when adjusting the pressure switch.**

## **WARNING !**

Never exceed the designed pressure for the system or overload the motor beyond its Maximum Amp Draw.

$$* \text{ Full Load Amps } \times \text{ Service Factor } = \text{ Maximum Amp Draw}$$

## **WARNING !**

Never assume a compressor is safe to work on just because it is not operating. It may be in the automatic stand-by mode and may restart any time. Follow all safety precautions outlined in **SECTION 5, Stopping For Maintenance**.

### ***Torquing Cylinder to Head Capscrews***

Torque cylinder to head capscrews to specifications listed in the parts book corresponding to the Record of Change for your compressor. Then, run the compressor for at least 1 hour. Shut the unit off and follow precautions outlined in **SECTION 5, Stopping for Maintenance**. Retorque the head capscrews to same specifications after the unit has cooled.

\* Full load amps (FLA) & Service Factor can usually be found on the motor nameplate.

† Reference torque spec. note in parts book corresponding to Record of Change for your compressor.

# PILOT VALVE ADJUSTMENTS

All adjustments made to the pilot valve must be performed by a qualified technician. The adjustments must be made while the unit is operating, therefore, extreme caution must be taken while working on the unit. Observe all necessary precautions. Always use a back-up wrench and make all differential and unload pressure adjustments in very small increments (1/8 turn).

## WARNING !

The pressure switch and / or pilot valve are set at the factory for maximum efficiency. Adjustments to either component must be performed by a qualified technician. Exceeding the factory recommended maximum pressure will void the warranty and may cause personal injury.

### Setting Unload Pressure

**Step 1.** Flip the toggle to the "RUN" position as shown, or turn the knurled knob (if so equipped) counterclockwise until it stops.

**Step 2.** Loosen locknut (counterclockwise). \* **Stabilize with back-up wrench!**

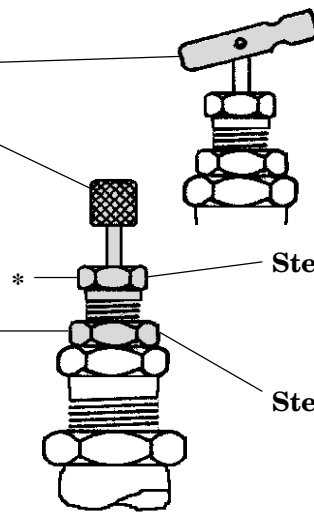

**Step 3.** Turn clockwise to increase unload pressure, turn counterclockwise to decrease unload pressure. Hold position with wrench and proceed to Step 4.

**Step 4.** Tighten locknut (clockwise) with wrench. \* **Stabilize with back-up wrench!**

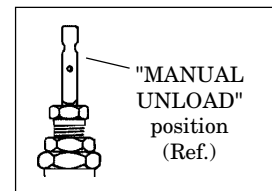

### Setting Differential Pressure

**Step 5.** Loosen locknut (counterclockwise). \* **Stabilize with back-up wrench!**

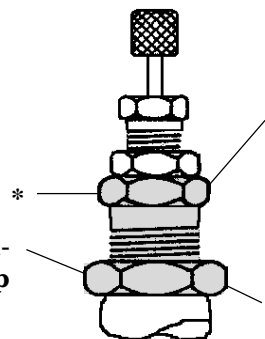

**Step 6.** Turn clockwise to decrease the differential pressure and counterclockwise to increase the differential pressure. Hold position with wrench and proceed to Step 7.

**Step 7.** Tighten locknut (clockwise) with wrench. \* **Stabilize with back-up wrench!**

Trouble	Probable Cause
<b>Low discharge pressure</b>	<ul style="list-style-type: none"> <li>•Restricted inlet</li> <li>•Defective compressor valves or valve unloading mechanism</li> <li>•Leaks in the compressed air distribution system at fittings, connections, etc.</li> <li>•Unloader pilot valve defective or set wrong</li> <li>•Pressure switch defective or set wrong</li> <li>•Drive belt slipping</li> <li>•Incorrect speed</li> <li>•Worn piston rings or loose piston</li> <li>•Leaking head gasket</li> <li>•Drain valve open</li> <li>•Defective pressure gauge</li> <li>•Excessive running clearances (<i>refer to SECTION 2, Specifications</i>)</li> <li>•Pressure relief valve leaking</li> <li>•Clogged intercooler</li> <li>•Loose compressor valves or leaking at valve gaskets</li> <li>•Compressor incorrectly sized for the altitude it is operating at</li> <li>•Piston rings not seated; allow 100 hours at full pressure</li> </ul>
<b>Water in the crankcase (lubricant appears milky)</b>	<ul style="list-style-type: none"> <li>•Compressor does not run long enough to get hot and vaporize the liquids squeezed out of the air during compression (<i>compressor may be too large for application</i>)</li> <li>•Incorrect or inferior grade of lubricant</li> <li>•System pressure leaking back through discharge valve</li> </ul>
<b>Rusty valves and/or cylinders</b>	<ul style="list-style-type: none"> <li>•Compressor operated too infrequently</li> <li>•Compressor does not run long enough to get hot and vaporize the liquids squeezed out of the air during compression (<i>compressor may be too large for application</i>)</li> <li>•Compressor not properly prepared for storage</li> <li>•Discharge line from compressor head is pointed upward allowing condensation to drain back at shutdown</li> </ul>
<b>Excessive vibration</b>	<ul style="list-style-type: none"> <li>•Incorrect speed</li> <li>•Compressor valves not functioning properly</li> <li>•Loose pulley/sheave</li> <li>•Motor or engine out of balance</li> <li>•Compressor, motor or engine not secured tightly, or tightened into a bind</li> <li>•Foundation or frame inadequate</li> <li>•Piping inadequately supported or tightened into a bind</li> <li>•Excessive discharge pressure</li> <li>•Compressor feet may need to be leveled with shims</li> </ul>

## Trouble

## Probable Cause

---

<b>Excessive drive belt wear</b>	<ul style="list-style-type: none"><li>•Pulley/sheave out of alignment</li><li>•Belt too loose or too tight</li><li>•Belt slipping</li><li>•Pulley/sheave wobbling</li><li>•Pulley/sheave groove damaged or rough</li><li>•Incorrect belts</li></ul>
<b>Low oil pressure</b>	<ul style="list-style-type: none"><li>•Oil sump strainer plugged</li><li>•Excessive leakage at crankshaft seals</li><li>•Low oil level</li><li>•Oil pump incorrectly assembled to the bearing carrier (“o”ring not properly located between oil pump body &amp; bearing carrier)</li><li>•Oil pressure adjusting screw not set properly</li><li>•Defective oil pressure gauge</li></ul>
<b>Compressor loads and unloads excessively</b>	<ul style="list-style-type: none"><li>•Air receiver too small</li><li>•Compressor valves or unloaders defective</li><li>•Excessive system leakage</li><li>•Compressor operating at incorrect speed</li><li>•Unloader pilot differential set too close</li><li>•Pressure switch defective</li></ul>
<b>Defective pressure switch</b>	<ul style="list-style-type: none"><li>•Moisture &amp;/or oil buildup on the pressure switch diaphragm</li><li>•Ruptured diaphragm</li><li>•Burned contact points</li><li>•Plugged air passage from the receiver to the pressure switch</li><li>•Loose electrical connection</li></ul>
<b>Excessive air pressure in air receiver</b>	<ul style="list-style-type: none"><li>•Air pressure gauge inaccurate</li><li>•Leaks in unloader piping system</li><li>•Defective compressor head unloader</li><li>•Pilot valve or pressure switch set incorrectly or defective</li><li>•Pressure switch wired incorrectly</li><li>•Tube to compressor head unloader plugged</li></ul>
<b>Excessive intercooler pressure</b> <i>(Two stage models only)</i>	<ul style="list-style-type: none"><li>•Intercooler restricted or plugged</li><li>•Compressor valves in second stage broken or not functioning properly</li><li>•Pilot valve or pressure switch set incorrectly or defective</li><li>•Pressure gauge defective</li></ul>

## Trouble

## Probable Cause

---

### Intercooler pressure abnormally low (Two stage models only)

- Compressor valves or head unloaders in first stage not functioning properly or defective
- Restricted air inlet filter or suction line
- Pilot valve or pressure switch set incorrectly or defective
- Pressurized air at head unloader not venting properly when demand for air is required
- Compressor valve or head gasket leaking
- Worn piston rings
- Defective pressure gauge
- Leaking air at intercooler or intercooler connections

### Compressor overheats

- Clogged intake system
- Defective compressor valves
- Pressure setting too high
- Clogged intercooler, internally or externally
- Inadequate ventilation, or recirculation of hot air
- Pulley/sheave rotation wrong
- Incorrect speed
- Running clearances insufficient (*piston to cylinder wall or running gear*)
- Lubrication inadequate
- Compressor incorrectly sized

### High discharge temperature

- Compressor valve assemblies defective
- Discharge pressure too high
- Inadequate ventilation or hot air recirculating
- Cooling surfaces of compressor or intercooler excessively dirty
- Internal surface of heat exchanger fouled
- Ambient temperature too high
- Scored or excessively worn cylinder walls

### Compressor knocks

- Head clearance insufficient
- Piston loose in cylinder bore, cylinder bore worn, piston or piston rings worn
- Worn rods or main bearing
- Wrong pressure setting, discharge pressure excessive
- Crankcase lubrication inadequate
- Loose pulley/sheave
- Compressor valve assemblies loose

## Trouble

## Probable Cause

---

<b>Excessive oil consumption</b>	<ul style="list-style-type: none"><li>• Compressor runs unloaded too long</li><li>• Worn piston rings</li><li>• Restricted intake system</li><li>• Compressor running too hot</li><li>• Breather valve not functioning properly</li><li>• Oil level in crankcase too high</li><li>• Oil viscosity wrong for the application</li><li>• Connecting rod out of alignment, bent or twisted</li><li>• Leaking oil seal</li><li>• Piston rings not seated (<i>allow 100 hours for seating</i>)</li><li>• Wrong oil (<i>may be a detergent oil with a tendency to foam</i>)</li><li>• Inferior grade of oil</li></ul>
<b>Excessive current draw</b> ( <i>To determine maximum amperage allowed, multiply the FLA on the motor nameplate by the service factor.</i> ) <b>CAUTION !</b> <b>Motor surface temperature normally exceeds 170° F.</b>	<ul style="list-style-type: none"><li>• Low voltage (<i>must be within 10% of nameplate voltage</i>)</li><li>• Loose electrical connection</li><li>• Wire size too small</li><li>• Incorrect oil</li><li>• Discharge pressure too high</li><li>• Intercooler plugging</li><li>• Bearings tight or seizing</li><li>• No crankshaft endplay</li><li>• Motor sized incorrectly</li><li>• Motor defective</li><li>• Drive belts too tight</li></ul>
<b>Failure to start</b>	<ul style="list-style-type: none"><li>• Power not on</li><li>• Blown circuit fuse</li><li>• Thermal overload fuses tripped</li><li>• Low voltage</li><li>• Faulty start switch</li><li>• Power failure</li><li>• Pressure switch incorrectly adjusted or faulty</li><li>• Loose or broken wire</li><li>• Motor defective</li><li>• Compressor seized</li></ul>
<b>Motor stalls</b>	<ul style="list-style-type: none"><li>• Motor overloaded (<i>refer to <b>Excessive current draw</b></i>)</li></ul>



## Decal Locations

A	23	ADDED 146002-4 AND 116119 DECALS.	599
---	----	-----------------------------------	-----

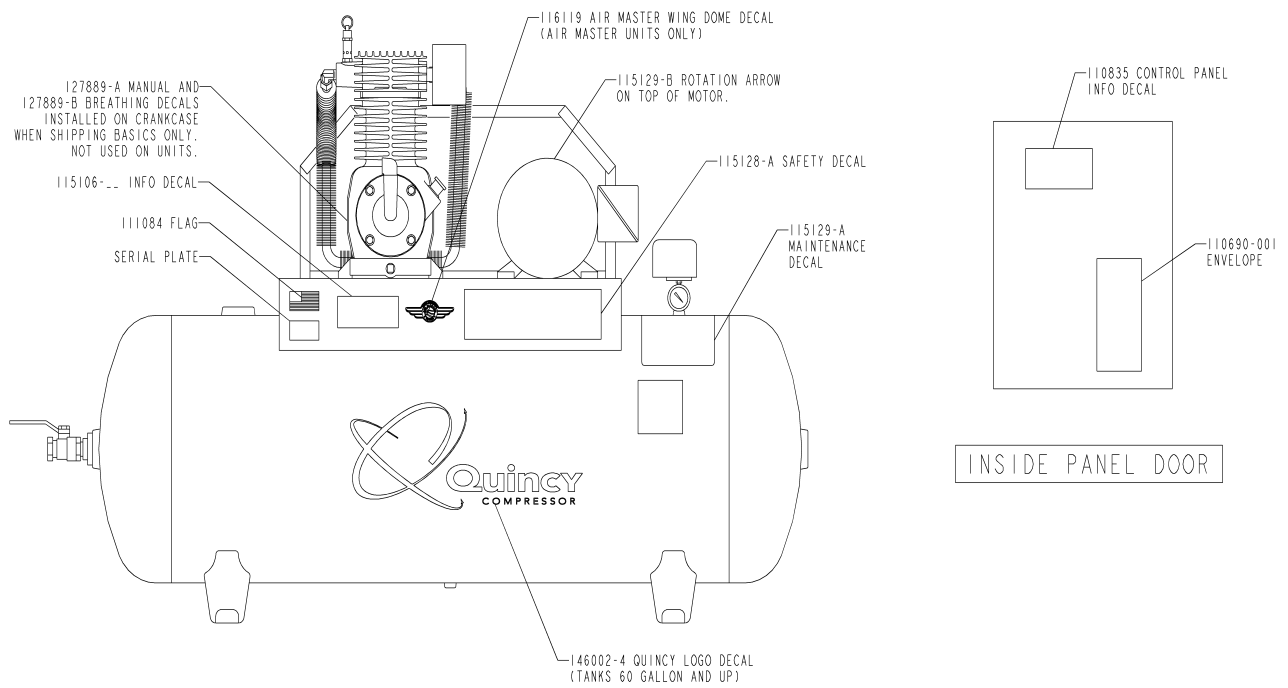

**Typical QT & PLT Series Unit with Horizontal Receiver**

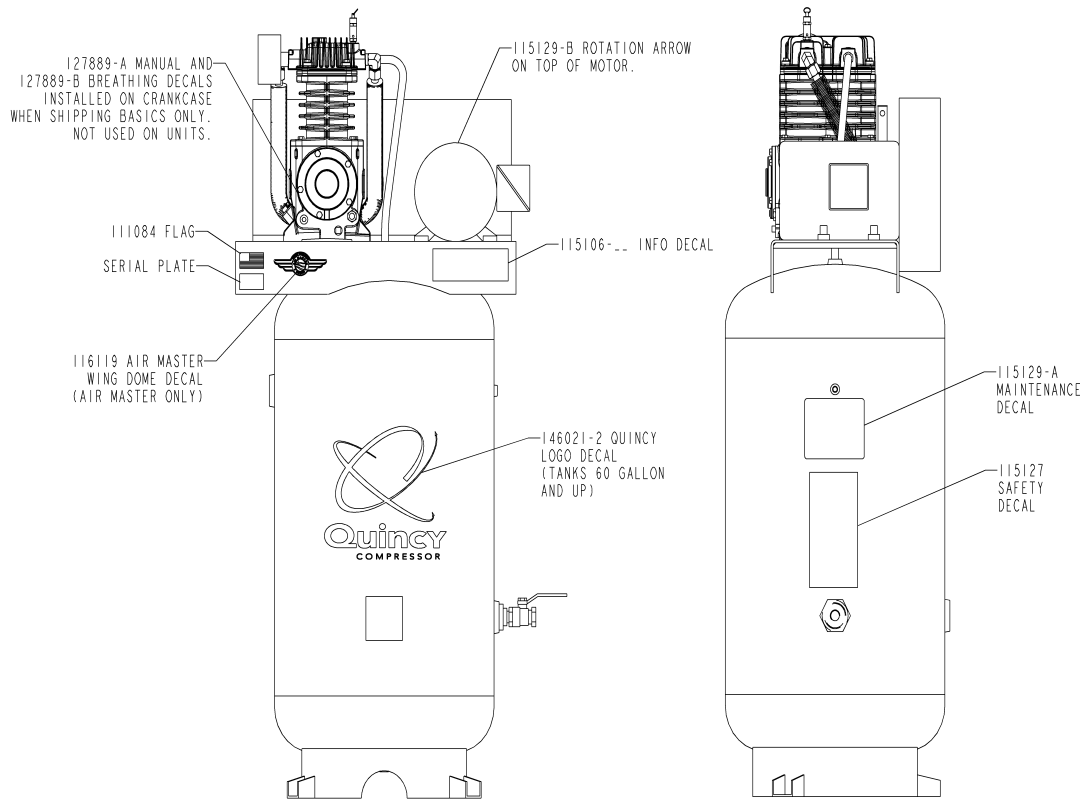

**Typical QT & PLT Series Unit with Vertical Receiver**

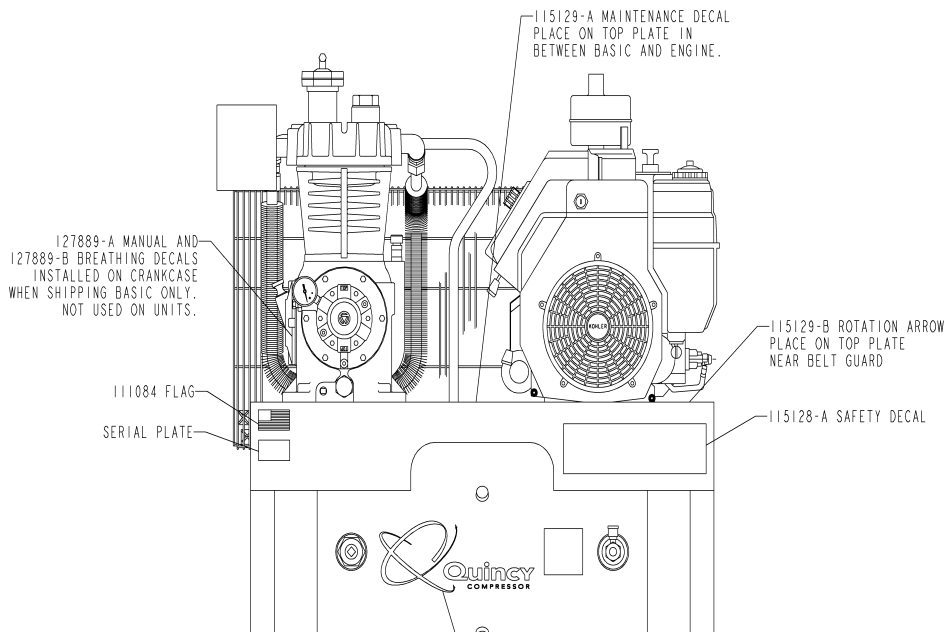

**Typical QT & PLT Series Engine Driven Unit with Horizontal Receiver**

## **QUINCY COMPRESSOR**

### **STANDARD TERMS AND CONDITIONS**

**LEGAL EFFECT:** Except as expressly otherwise agreed to in writing by an authorized representative of Seller, the following terms and conditions shall apply to and form a part of this order and any additional and/or different terms of Buyer's purchase order or other form of acceptance are rejected in advance and shall not become a part of this order.

The rights of Buyer hereunder shall be neither assignable nor transferable except with the written consent of Seller.

This order may not be canceled or altered except with the written consent of Seller and upon terms which will indemnify Seller against all loss occasioned thereby. All additional costs incurred by Seller due to changes in design or specifications, modification of this order or revision of product must be paid for by Buyer.

In addition to the rights and remedies conferred upon Seller by this order, Seller shall have all rights and remedies conferred at law and in equity and shall not be required to proceed with the performance of this order if Buyer is in default in the performance of such order or of any other contract or order with seller.

**TERMS OF PAYMENT:** Unless otherwise specified in the order acknowledgment, the terms of payment shall be 1% 15, net forty-five (45) days after shipment. These terms shall apply to partial as well as complete shipments. If any proceeding be initiated by or against Buyer under any bankruptcy or insolvency law, or in the judgment of Seller the financial condition of Buyer, at the time the equipment is ready for shipment, does not justify the terms of payment specified, Seller reserves the right to require full payment in cash prior to making shipment. If such payment is not received within fifteen (15) days after notification of readiness for shipment, Seller may cancel the order as to any unshipped item and require payment of its reasonable cancellation charges.

If Buyer delays shipment, payments based on date of shipment shall become due as of the date when ready for shipment. If Buyer delays completion of manufacture, Seller may elect to require payment according to percentage of completion. Equipment held for Buyer shall be at Buyer's risk and storage charges may be applied at the discretion of Seller.

Accounts past due shall bear interest at the highest rate lawful to contract for but if there is no limit set by law, such interest shall be eighteen percent (18%). Buyer shall pay all cost and expenses, including reasonable attorney's fees, incurred in collecting the same, and no claim, except claims within Seller's warranty of material or workmanship, as stated below, will be recognized unless delivered in writing to Seller within thirty (30) days after date of shipment.

**TAXES:** All prices exclude present and future sales, use, occupation, license, excise, and other taxes in respect of manufacture, sales or delivery, all of which shall be paid by Buyer unless included in the purchase price at the proper rate or a proper exemption certificate is furnished.

**ACCEPTANCE:** All offers to purchase, quotations and contracts of sales are subject to final acceptance by an authorized representative at Seller's plant.

**DELIVERY:** Except as otherwise specified in this quotation, delivery will be F. O. B. point of shipment. In the absence of exact shipping instruction, Seller will use its discretion regarding best means of insured shipment. No liability will be accepted by Seller for so doing. All transportation charges are at Buyer's expense. Time of delivery is an estimate only and is based upon the receipt of all information and necessary approvals. The shipping schedule shall not be construed to limit seller in making commitments for materials or in fabricating articles under this order in accordance with Seller's normal and reasonable production schedules.

Seller shall in no event be liable for delays caused by fires, acts of God, strikes, labor difficulties, acts of governmental or military authorities, delays in transportation or procuring materials, or causes of any kind beyond Seller's control. No provision for liquidated damages for any cause shall apply under this order. Buyer shall accept delivery within thirty (30) days after receipt of notification of readiness for shipment. Claims for shortages will be deemed to have been waived if not made in writing with ten (10) days after the receipt of the material in respect of which any such shortage is claimed. Seller is not responsible for loss or damage in transit after having received "In Good Order" receipt from the carrier. All claims for loss or damage in transit should be made to the carrier.

**TITLE & LIEN RIGHTS:** The equipment shall remain personal property, regardless of how affixed to any realty or structure. Until the price (including any notes given therefore) of the equipment has been fully paid in cash, Seller shall, in the event of Buyer's default, have the right to repossess such equipment.

**PATENT INFRINGEMENT:** If properly notified and given an opportunity to do so with friendly assistance, Seller will defend Buyer and the ultimate user of the equipment from any actual or alleged infringement of any published United States patent by the equipment or any part thereof furnished pursuant hereto (other than parts of special design, construction, or manufacture specified by and originating with Buyer), and will pay all damages and costs awarded by competent court in any suit thus defended or of which it may have had notice and opportunity to defend as aforesaid.

**STANDARD WARRANTY:** Seller warrants that products of its own manufacture will be free from defects in workmanship and materials under normal use and service for the period specified in the product instruction manual. Warranty for service parts will be Ninety (90) days from date of factory shipment. Electric Motors, gasoline and diesel engines, electrical apparatus and all other accessories, components and parts not manufactured by Seller are warranted only to the extent of the original manufacturer's warranty.

Notice of the alleged defect must be given to the Seller, in writing with all identifying details including serial number, type of equipment and date of purchase within thirty (30) days of the discovery of the same during the warranty period.

Seller's sole obligation on this warranty shall be, at its option, to repair or replace or refund the purchase price of any product or part thereof which proves to be defective. If requested by Seller, such product or part thereof must be promptly returned to seller, freight prepaid, for inspection.

Seller warrants repaired or replaced parts of its own manufacture against defects in materials and workmanship under normal use and service for ninety (90) days or for the remainder of the warranty on the product being repaired.

This warranty shall not apply and Seller shall not be responsible or liable for:

- (a) Consequential, collateral or special losses or damages;
- (b) Equipment conditions caused by fair wear and tear, abnormal conditions of use, accident, neglect or misuse of equipment, improper storage or damage resulting during shipping;
- (c) Deviation from operating instructions, specifications or other special terms of sale;
- (d) Labor charges, loss or damage resulting from improper operation, maintenance or repairs made by person(s) other than Seller or Seller's authorized service station.

In no event shall Seller be liable for any claims whether arising from breach of contract or warranty or claims of negligence or negligent manufacture in excess of the purchase price.

**THIS WARRANTY IS THE SOLE WARRANTY OF SELLERS AND ANY OTHER WARRANTIES, WHETHER EXPRESSOR IMPLIED IN LAW OR IMPLIED IN FACT, INCLUDING ANY WARRANTIES OF MERCHANTABILITY AND FITNESS FOR PARTICULAR USE ARE HEREBY SPECIFICALLY EXCLUDED.**

**LIABILITY LIMITATIONS:** Under no circumstances shall the Seller have any liability for liquidated damages or for collateral, consequential or special damages or for loss of profits, or for actual losses or for loss of production or progress of construction, whether resulting from delays in delivery or performance, breach of warranty, negligent manufacture or otherwise.

**ENVIROMENTAL AND OSHA REQUIREMENTS:** At the time of shipment of the equipment from the factory, Quincy Compressor / Ortman Fluid Power will comply with the various Federal, State and local laws and regulations concerning occupational health and safety and pollution. However, in the installation and operation of the equipment and other matters over which the seller has no control, the Seller assumes no responsibility for compliance with those laws and regulations, whether by the way of indemnity, warranty or otherwise.

June 30, 2003

## MAINTENANCE SCHEDULE CHECKLIST

Use this form to develop a routine maintenance schedule and record of performed maintenance. In the numbered columns enter the initials of the person who performed the maintenance and the date. Enter additional maintenance procedures in the spaces provided in the left hand column as needed per your application.

Equipment operating under humid or dirty conditions may require shorter intervals between scheduled maintenance.

The instruction manual provided with Quincy Compressor products, as well as any instructions supplied by manufacturers of supporting equipment, should be read and understood prior to performing maintenance.

**NOTE: Make your entries on a copy of this form. Retain this original form to make more copies in the future.**

### Suggested Weekly (40 hrs.) Intervals

Maintenance Procedures	1	2	3	4	5	6	7	8	9	10	11	12
•manually test pressure relief valves												
•												
•clean surfaces of intercooler												
•												
•check distribution system for leaks												
•												
•check for contaminated lubricant *												
•												
•check for compressor/vacuum leaks												
•												
•												

### Suggested Monthly (160 hrs.) Intervals

Maintenance Procedures	1	2	3
•check belt tension (if applicable)			
•			
•torque sheave fasteners (if applicable)			
•			
•change lubricant (& filter if applicable)*			
•			

\*QRD Series excluded



an EnPro Industries company

**Reciprocating / Systems:** 217.222.7700  
**Air Master** 217.277.0270  
**E-mail:** info@quincycompressor.com  
**Website:** quincycompressor.com  
quincyairmaster.com



© 2006 Quincy Compressor, an EnPro Industries company  
All Rights Reserved. Litho in U.S.A.