

# ROTARY LIFT

WORLD LEADER IN LIFT SYSTEMS

A **DOVER** INDUSTRIES COMPANY

## MODELS: SPO9-100 PARTS BREAKDOWN (Non-Seismic Lift)

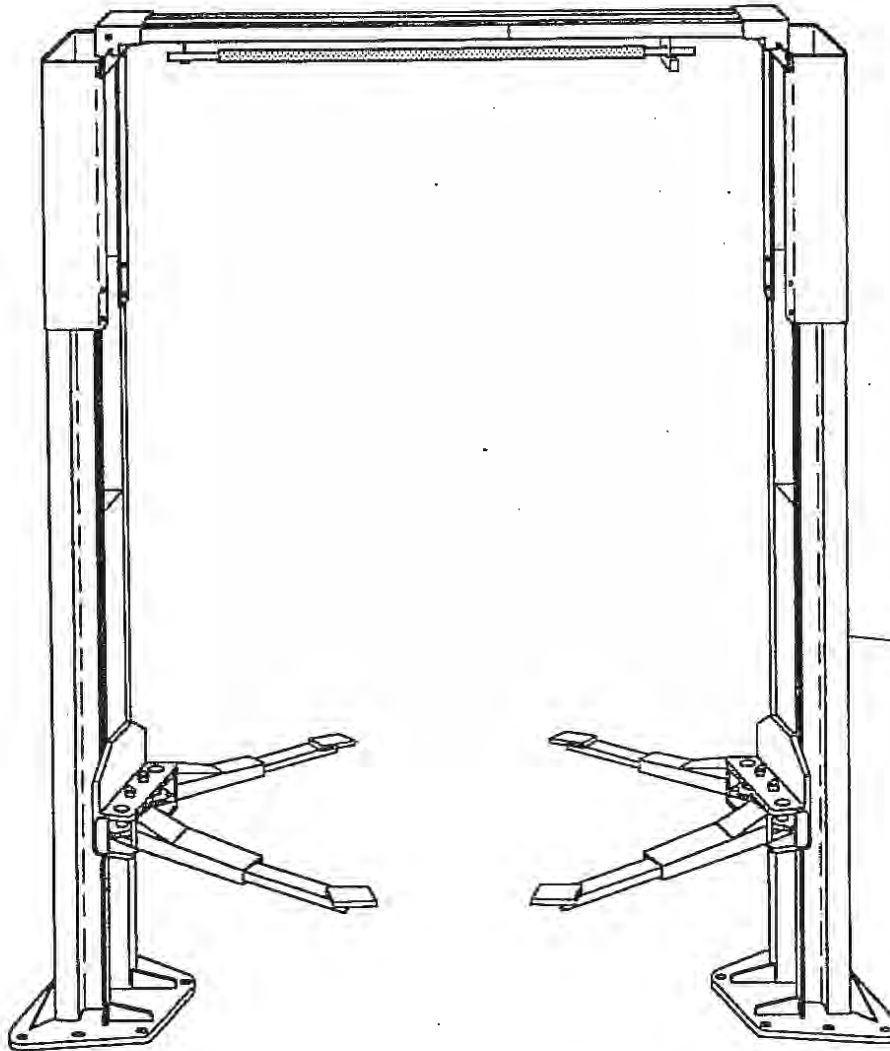

ETL Listed

NAROW 4-17-95

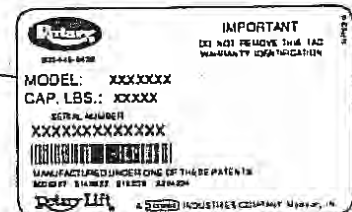

**IMPORTANT:** When ordering parts or requesting service always give exact model and power unit serial number. Model number is shown on nameplate attached to base of Power Unit column. Power unit serial number is located on side of power unit reservoir.

### NOTES:

- New power unit models are now being used. Models are as follows:  
SPO9 single phase = P702 replaced previous model P602. ←  
SPO9 three phase = P704 replaced previous model P604.

**PANZITTA SALES & SERVICE**  
72 George Avenue  
Wilkes-Barre, PA 18705  
570-822-6720 800-822-6720  
[www.panzittasales.com](http://www.panzittasales.com)

**NOTE:** For Replacement Parts - See Your Nearest Rotary Parts Distributor

## SPO9 PARTS LIST

ITEM NO.	DESCRIPTION	SPO9 PART NO.	ITEM NO.	DESCRIPTION	SPO9 PART NO.
1	L.H. Column Weldment	N75	35 †	Adjustment Bolts & Washers	†
2	R.H. Column Weldment	N76	36	Gear Bolts 3/8"-16NC x 1 1/2"	40200
3	Column Extension	N45		HHCS Grade 5	
4	Carriage Yoke Weldment	N86	37	3/8" Spring Washers	40818
5	Outer Arm	FJ7772-1	38	Restraint Gear	FJ7750
6	Outer Arm	FJ7772-1	39	Slider Block	FJ7360
7	Hydraulic Cylinder	FJ7664	40	3/4" Concrete Anchor (14 Req'd)	FJ7380
8	Power Unit	See "Notes" On Front Cover	41	1 1/2" O.D. x .760-.770" I.D.	41388
9	Power Unit Hose	FJ837		x .045" Thick Mach. Bushing	
10	5/16"-18NC x 3/4" Bolt, Ext Tooth LW&Nut	40224	42	1/4"-20NC x 2" HHCS	40109
11	Inner Arm	FJ7416-2	43	1/4" — 20NC Insert Lock Nut	41423
12	3/8" 16NC x 5/8" Lg. HHCS Gr.8	40155	44	1/8" x 1" Lg. Cotter Pin	41200
13	3/8" Internal Tooth Lockwasher	40843	45 @@	Limit Switch Assembly	FJ7613 @@
14	Order with Complete Ass'y item #11	FJ7416-2	46	Switch Bar Assembly	FJ7613-2
15	High Step Adapter	FJ671-1	47	R.H. Latch Sheave Bracket Assy	FJ7767
16	Low Step Adapter	FJ671-2	48	R.H. Overhead Weldment	N44-1
17	Adapter Pin	FJ671-3	49	3/8" — 16NC x 3/4" Long HHCS	40134
18	3/32" Hog Ring For 1/2" Shaft	FJ671-6	50	3/8" Flat Washer	40820
19	Adapter Swivel Pin	FJ79-6	51	Overhead Hose	FJ839
20	Bleeder Screw MF (specify manufacturer)	2 REO'D	52	Equalizer Cable Assembly	FJ7450
21	Carriage Bumper	FJ7391-2	53	L.H. Overhead Weldment	N43-1
22	Arm Pin	FJ7838	54	Locking Latch Cable Assembly	FJ7594-1
23	Approach Bumper (Door-18" Lg-2 Req'd)	FJ7391-1	55	3/8" — 16NC x 1" Flanged HHCS	40144
24	1/2" — 13NC Hex Lock Nut	40703	56	3/8" — 16NC Flanged Locknut	40664
25	3/16" x 2" Long Cotter Pin	41250	57	Sheave Shaft	FJ7444-8
26	Truarc #5304-75 Klipping for 3/4" Shaft	41411	58	Bracket	FJ7613-1
27	Sheave	FJ7116-1	59	1/4"-20NC x 3/4" HHCS Grade 5	40104
28	Wheel Spotting Dish Kit	FF729	60	L.H. Latch Sheave Bracket Assy	FJ7766
29	Actuator Pin Handle	FJ7985-1	61	Locking Latch Sheave	FJ7322
30	Actuator Pin	FJ7656-1	62	Truarc Klip #5304-37 for 3/8" Shaft	41410
31	Retaining Ring	FJ7646-2	63	Hose Clip (4 Req'd)-Overhead	FJ7206
32	Arm Restraint Spring	FJ7656-2	64	#10 — 24NC x 3/8" Lg. Slotted	40033
33	120T Gear Block	FJ7749		HHTS (For Overhead)	
34	Spring Pin, 1/4" dia. x 1 1/2" Lg. (stainless)	14427		5/16" — 18NC x 3/8" Lg. Slotted	
34b	1/4"-20NC Zinc Hex Nut	40627		PHMS (For Columns)	40227
34c	Sheave Cover	N119-1	65	Branch Tee	FJ7668
34d	1/4"-20NC PHMS x 3/8" Lg. Plated (2pcs.)	40063	66	Hose Clip, Column, 6 Req'd	FJ7499
			67	3/8"-16NC x 3/8" Lg. Flanged HHCS	40122
			68	1/4" - 20NC Flanged Locknut	40641
			69	3/4" Spacer	FJ7871
			70@@	3 Phase Limit Switch Assy. For Units Using Above 250V.	FJ7979
			71	Single Phase Limit Switch (only)	P461-2
			72 ▲	Three Phase Limit Switch (only)	FJ7979-1
			73	Limit Switch Bracket Cover	FJ7979-2
			74	1/4" External Tooth Lockwasher	40779
			75	3/8" External Tooth Lockwasher	40845
			76 **	Arm Restraint Kit (1 Arm)	FJ7888

Wheel Spotting Dish

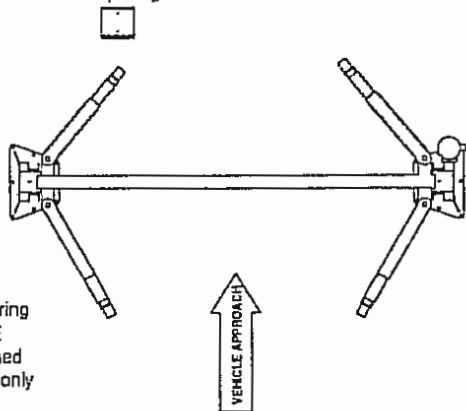

† Adjustment bolt, spring washer(s) and SAE washer(s) determined at assembly. Used only if required.

Bolt - 5/16"-18NC x 5/8" Lg. SHCS  
Spring Lock Washer - .078" thick  
SAE Washer - 11/32" I.D. x 11/16" O.D. x 1/16" thick

\*\*\* Includes item No#s 29, 30, 31, 32, 33, 34, 35, 36, 37 & 38

@@ Includes item 58, 73 & 74

▲ For units using above 250V. 250V and lower use P461-2 switch.

**PANZITTA SALES & SERVICE**  
72 George Avenue  
Wilkes-Barre, PA 18705  
570-822-6720 800-822-6720  
www.panzittasales.com

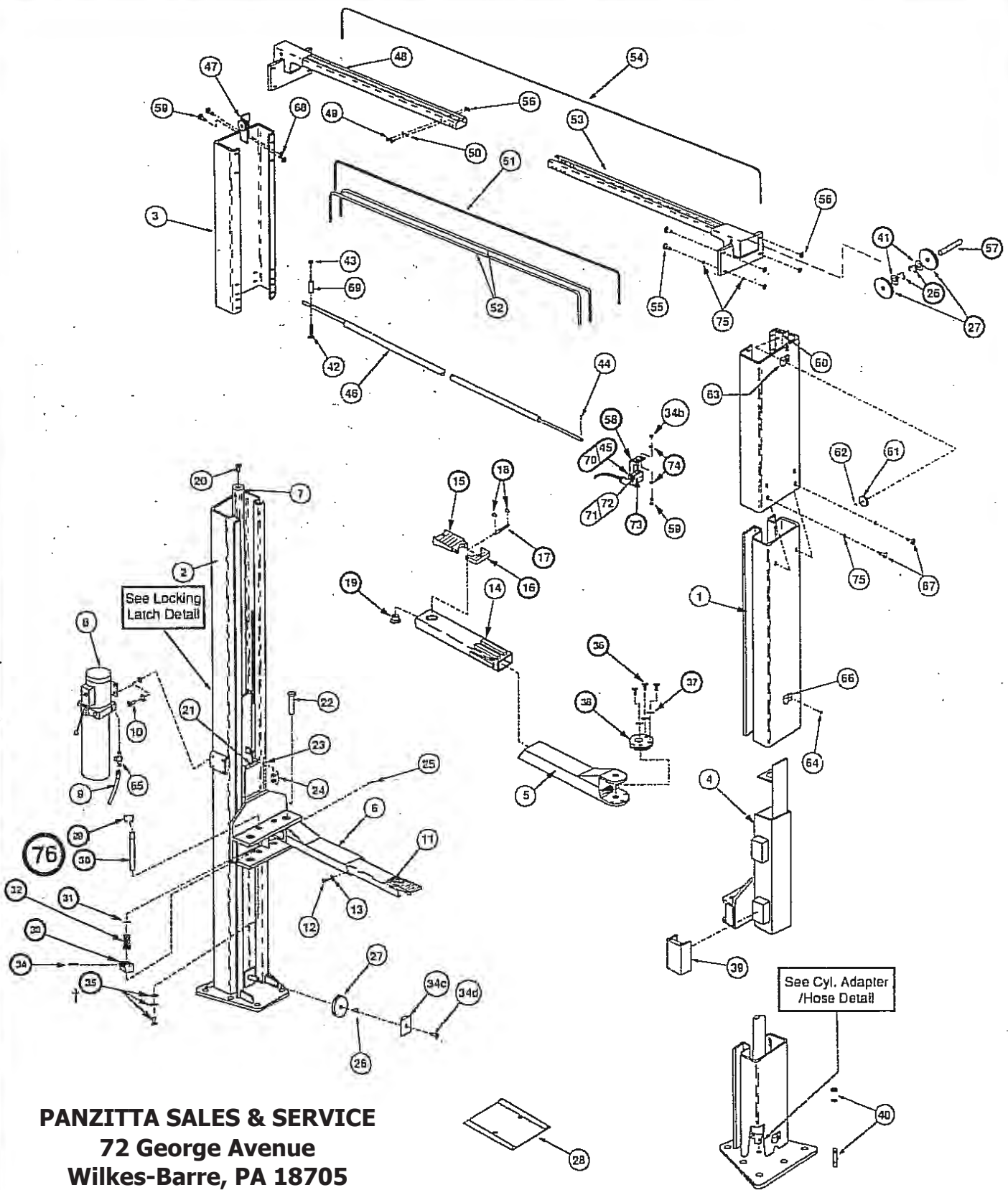

**PANZITTA SALES & SERVICE**  
 72 George Avenue  
 Wilkes-Barre, PA 18705  
 570-822-6720 800-822-6720  
 www.panzittasales.com

For Extended Height Models Use Part Numbers Below As Cross Reference, All Other Parts Are Common

	#3-Column Extensions	#55-Overhead Hose	#56-Equalizer Cables	#58-Locking Latch Cable
SPO9 EH-1	N46	FJ842	FJ7547	FJ7595-1
SPO9 EH-2	N47	FJ843	FJ7528	FJ7595-1

# CYLINDER ADAPTER / HOSE DETAIL

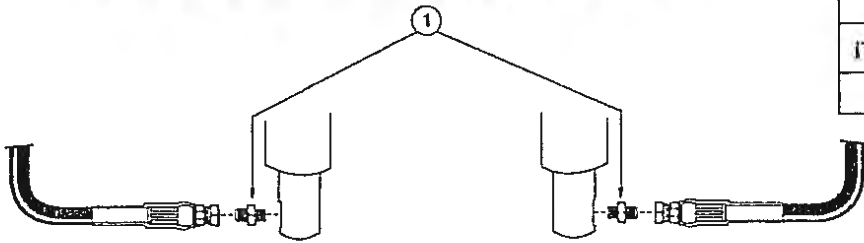

## CYLINDER ADAPTER/HOSE DETAIL PARTS LIST

ITEM NO.	DESCRIPTION	PART NO.
1	Straight Adapter	FJ7352-3

## RIGHT COLUMN

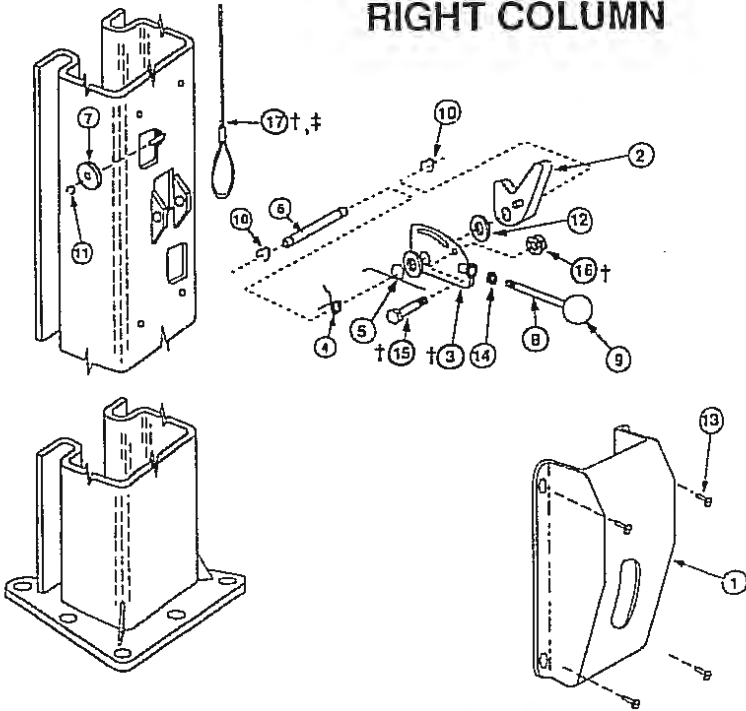

## LOCKING LATCH DETAIL PARTS LIST

ITEM NO.	DESCRIPTION	PART NO.
1	Control Side Cover	FJ7452
2	Locking Latch Dog	FJ7382-7
3	Control Plate	FJ7594-2
4	Spring	FJ7382-2
5	Spring	FJ7382-9
6	Latch Shaft	FJ7382-3
7	Locking Latch Sheave	FJ7322
8	Handle	FJ7382-18
9	Ball Handle	FC134-91
10	Truarc Klipring #5304-75 for $\frac{3}{4}$ " Shaft	41411
11	Truarc Klipring #5304-37 for $\frac{3}{8}$ " Shaft	41410
12	1 $\frac{1}{2}$ " O.D. x $\frac{3}{4}$ " I.D. x .045" Mach. Bush.	41388
13	$\frac{5}{16}$ " - 18NC x $\frac{3}{8}$ " Lg. Slotted Pan Hd. Screw	40227
14	$\frac{3}{8}$ " - 16NC Hex Jam Nut	40658
15 †	Shoulder Bolt, $\frac{5}{16}$ " x 1" - $\frac{1}{4}$ " 20 NC	40220
16 †	Flanged Locknut, $\frac{1}{4}$ " - 20 NC	41423
17 †	Latch Cable	FJ7594-1
‡	For EH-1 & EH-2 Model SPO9	FJ7595-1

† - Locking Latch Retrofit Kit FJ7594; FJ7595 (EH-1 & 2)  
Includes: 1 pc. #3, 1 pc. #17, 2 pcs. #15, 2 pcs #16,  
1 pc. #3 (left side below), 1 pc. #15 (left side below)

## LEFT COLUMN

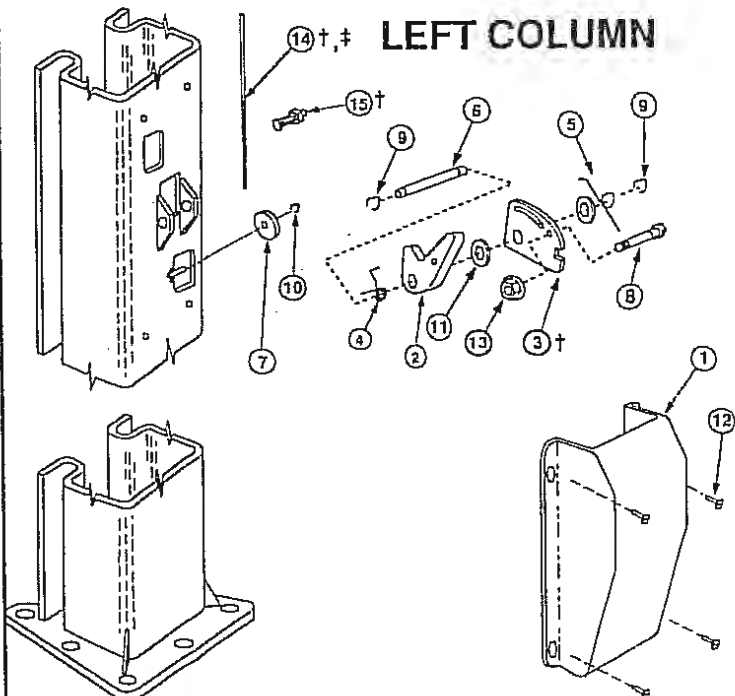

## LOCKING LATCH DETAIL PARTS LIST

ITEM NO.	DESCRIPTION	PART NO.
1	Latch Cover	FJ7451
2	Locking Latch Dog	FJ7382-7
3 †	Control Plate	FJ7382-5
4	Spring	FJ7382-2
5	Spring	FJ7382-9
6	Latch Shaft	FJ7382-3
7	Locking Latch Sheave	FJ7322
8	Shoulder Bolt $\frac{5}{16}$ " x 1" - $\frac{1}{4}$ " - 20NC	40220
9	Truarc Klipring #5304-75 for $\frac{3}{4}$ " Shaft	41411
10	Truarc Klipring #5304-37 for $\frac{3}{8}$ " Shaft	41410
11	1 $\frac{1}{2}$ " O.D. x $\frac{3}{4}$ " I.D. x .045" Mach. Bush.	41388
12	$\frac{5}{16}$ " - 18NC x $\frac{3}{8}$ " Lg. Slotted Pan Hd. Screw	40227
13	Flanged Locknut, $\frac{1}{4}$ " - 20 NC	41423
14	Latch Cable	FJ7594-1
15	Latch Cable Clamp (BURNDY)	KS-15
‡	For EH-1 & EH-2 Model SPO9	FJ7595-1

† Locking Latch Retrofit Kit FJ7594; FJ7595 (EH-1 & 2)  
(see Right Column for items included)

**Rotary Lift**®

**PANZITTA SALES & SERVICE**  
72 George Avenue  
Wilkes-Barre, PA 18705  
570-822-6720 800-822-6720  
www.panzittasales.com