



# Models: WO9

(For WO9-100 to -199 Lifts)

## Two Post Surface Mounted Lift

(Non-Seismic Lift)

### INSTALLATION INSTRUCTIONS

WO9 Capacity 9,000 lbs.

2250 lbs. per arm



ETL Listed

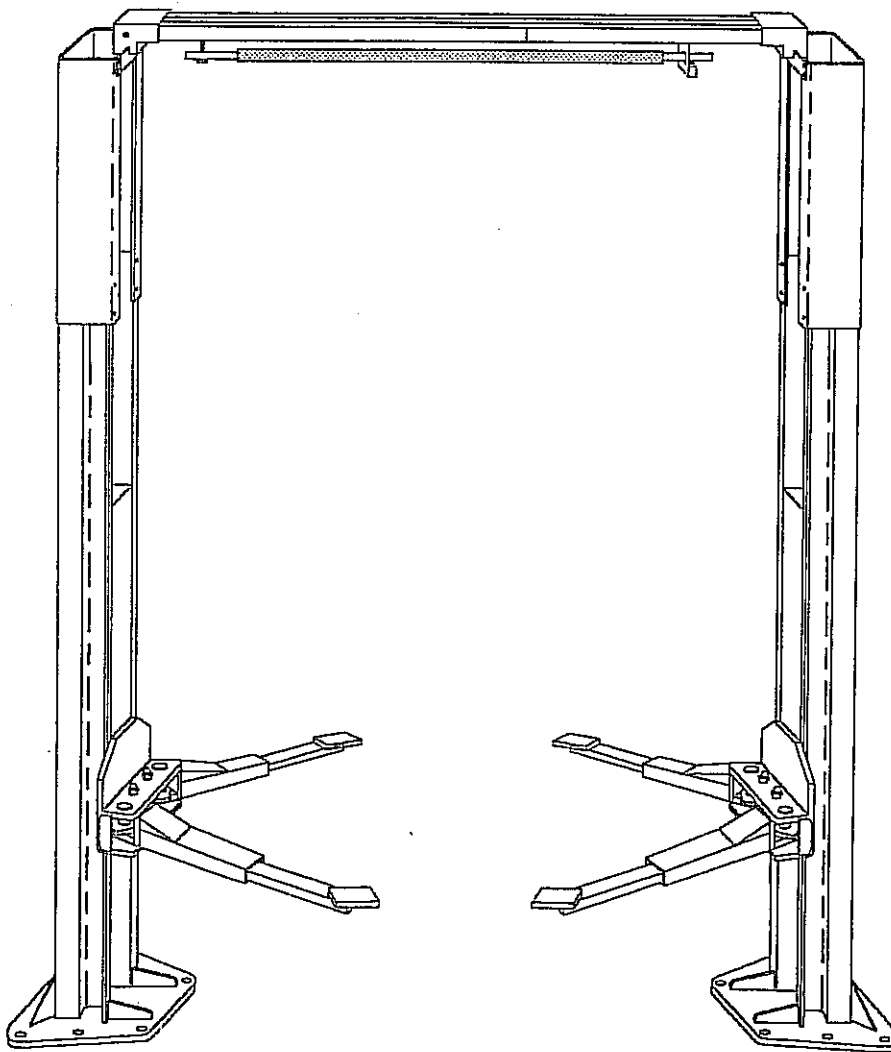

**ROTARY LIFT**  
A Dover Industries Company  
P.O. Box 1560  
Madison, Indiana 47250-0560  
Phone toll-free: 1-800-445-LIFT (5438)  
(812) 273-1622  
FAX : (800) 822-6502

For Export  
**ROTARY LIFT EXPORT COMPANY**  
200 Executive Drive, Suite 320  
West Orange, NJ 07052  
(201) 325-3535  
Telax # 13-8693  
FAX: (201) 325-7974

For Canada:  
**DOVER CORPORATION CANADA - ROTARY LIFT DIVISION**  
130 Bridgeland Avenue, Unit 210  
Toronto, Ontario, Canada M8A 1Z4  
(416) 256-4100  
FAX : (416) 256-3924

# INSTALLATION INSTRUCTIONS

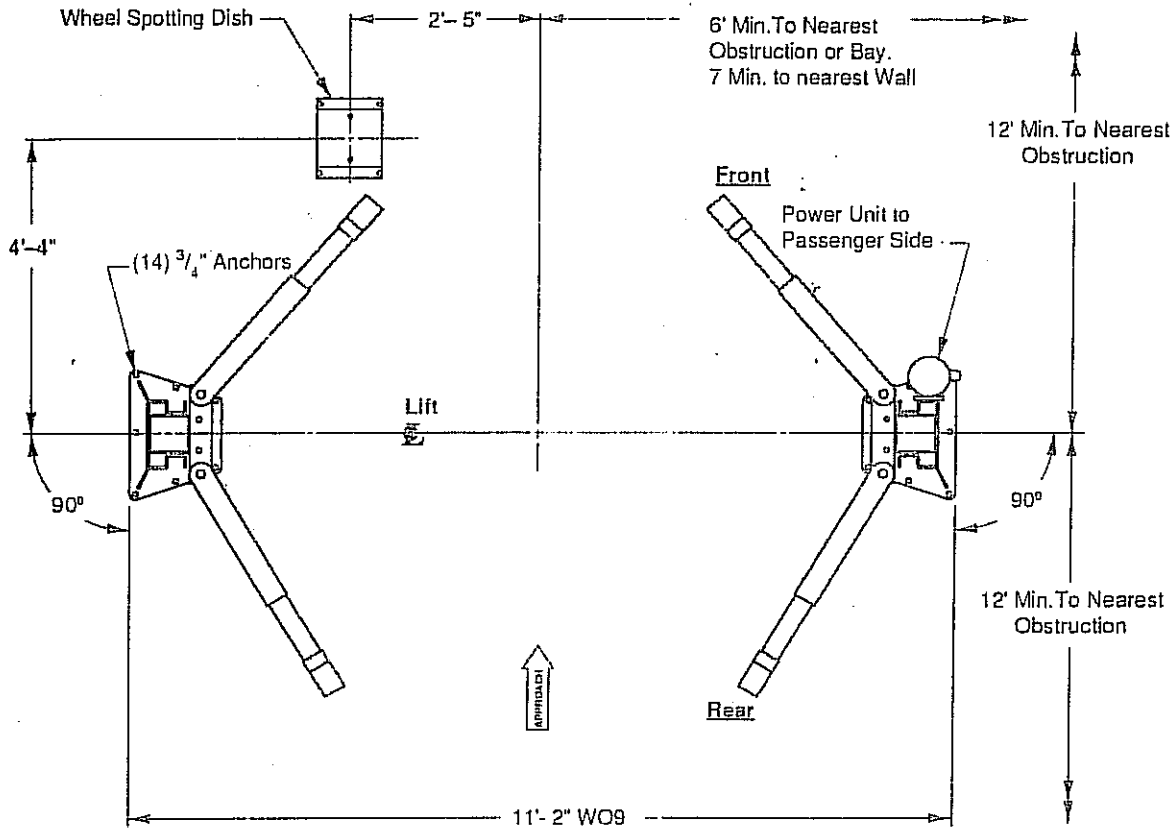

Fig. 1

- Lift Location:** Use architects plan when available to locate lift. Fig. 1. shows dimensions of a typical bay layout.
- Lift Height:** See Fig 4 for overall lift height of each specific lift model. Add 1" min. to overall lift model height to lowest obstruction.

**WARNING** Do Not install this lift in a pit or depression due to fire or explosion risks.

- Lift Setting:** Position columns in bay using dimensions shown in Fig. 1. Place column with power unit mounting bracket on vehicle passenger side of lift. Both column base plate backs must be square on center line of lift. Notches are cut into each base plate to indicate center line of lift. Manually raise carriage to first latch position.

- Drilling existing floor:** Drill (14)  $\frac{3}{4}$ " dia. holes  $4\frac{1}{2}$ " minimum depth in concrete floor using holes in column base plate as a guide, Fig. 1 & 2. A minimum hole spacing of  $6\frac{1}{2}$ " from another lift or other equipment and a minimum edge distance of  $4\frac{7}{8}$ " is suggested.
- For new floor construction:** A min. concrete thickness of 5" and a minimum concrete strength of 3500 psi. is suggested. Follow the same hole drilling and spacing instructions as for existing floor.

**CAUTION** Do not install on asphalt or other similar unstable surfaces. Columns are supported only by anchors in floor.

- Using shims provided, shim each column base until each column is plumbed properly, using a level of 36" or longer.

Plumb the columns first front and rear, then, side-to-side. Maximum shim thickness is  $\frac{1}{2}$ ", Fig. 3. Recheck column for plumb. Reshim if necessary. Tighten anchor bolts to an installation torque of 150 ft.-lbs.

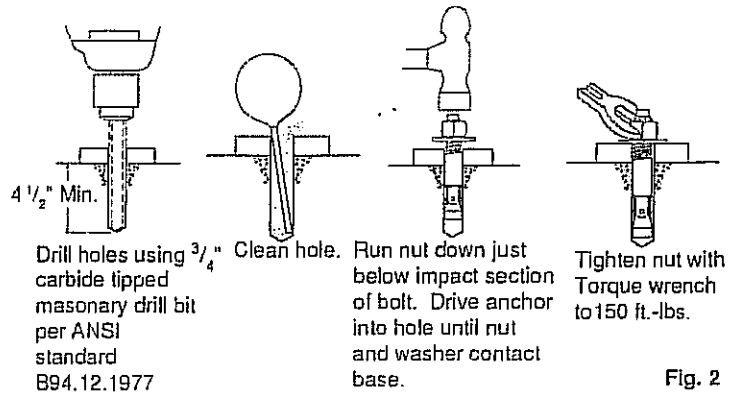

Fig. 2

Installation Torque Of 150 ft.-lbs. Is Required For All Anchor Bolts.

**NOTE:** On inner bolts, flush nut with top of bolt to avoid grinding it down after installing, as top of bolts may keep arm from swinging, or arm restraints from disengaging.

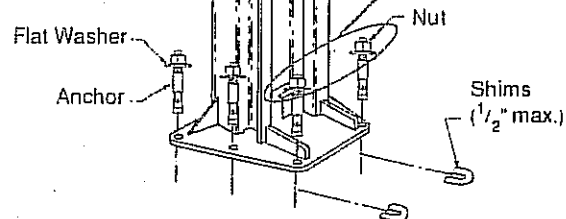

Fig. 3

### IMPORTANT

• All Star Washers are to be mounted on the Right side column to ensure grounding of overhead limit switch. Star Washers are not needed when mounting to Left Side column. Notice the column extension mounting, Fig.4, and overhead limit switch mounting as well in Fig.6.

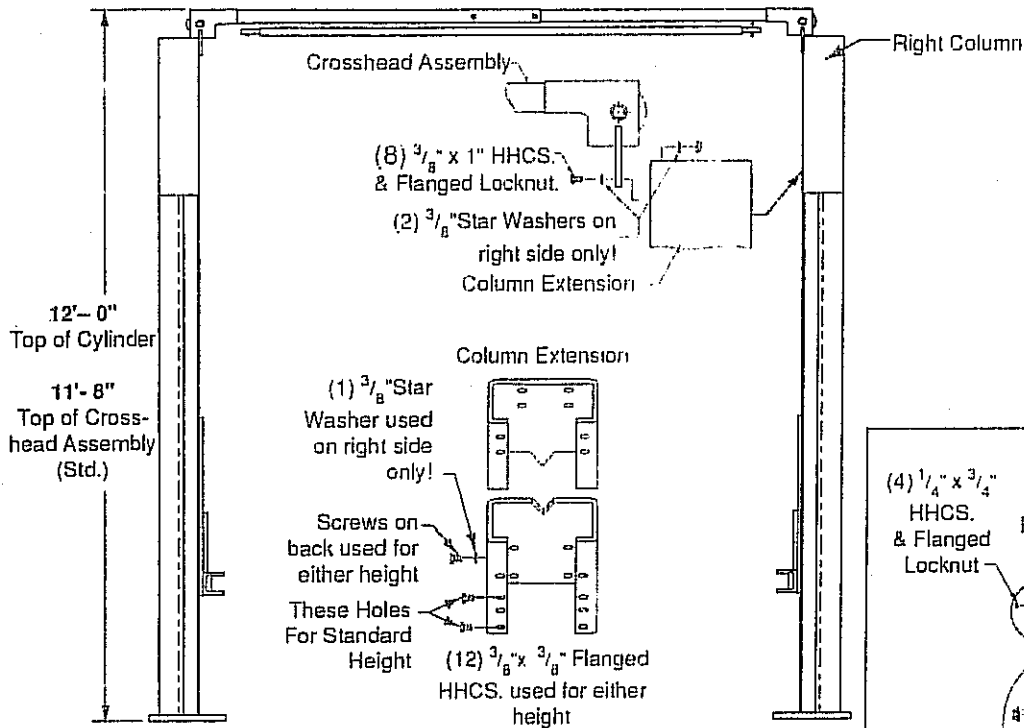

Fig. 4

### APPROACH SIDE

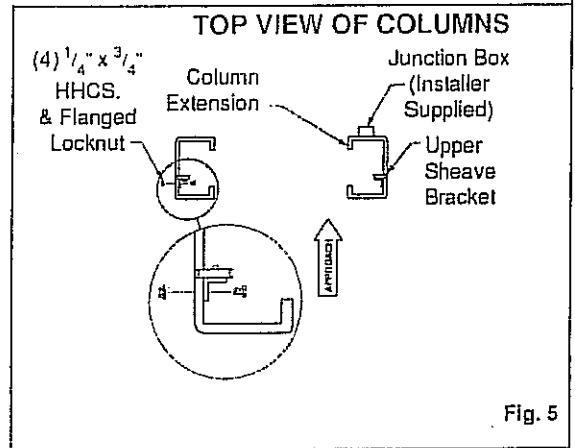

Fig. 5

If anchors do not tighten to 150 ft.-lbs. installation torque, in existing floor, replace concrete under each column base with a 4' x 4' x 6" thick 3500 psi minimum concrete pad keyed into and flush with the top of existing floor.

5. While still on the ground, install left hand and right hand upper latch cable sheave brackets to column extensions with (4) 1/4" x 3/4" lg. Hex Cap Screw and Flanged Locknuts, Fig. 5.

**Note:** Upper Sheave Bracket must be toward approach side of the column extension. Install a junction box (Installer Supplied) to power unit column extension using slot provided.

6. Install column extensions to columns using (12) 3/8" x 3/8" lg. Flanged Hex Cap Screws, Fig. 4. Adjust column extensions plumb as required.

7. Adjust crosshead to dim."A", Fig. 6, and install (4) 3/8" x 3/4" HHCS & flanged locknuts, do not tighten. Mount switch assembly towards power unit column as shown, using (2) 1/4" x 3/4" lg. HHCS, nuts and 1/4" Star Washers. Insert 1/4" x 2" Hex bolt through pivot hole in end of switch bar. Insert opposite end (weighted end) of bar through slot in switch mounting bracket. Then secure Hex bolt and switchbar to overhead as shown, using 3/4" spacer and lock nut. Tighten Hex bolt leaving 1/16" gap between the spacer and the crosshead assembly.

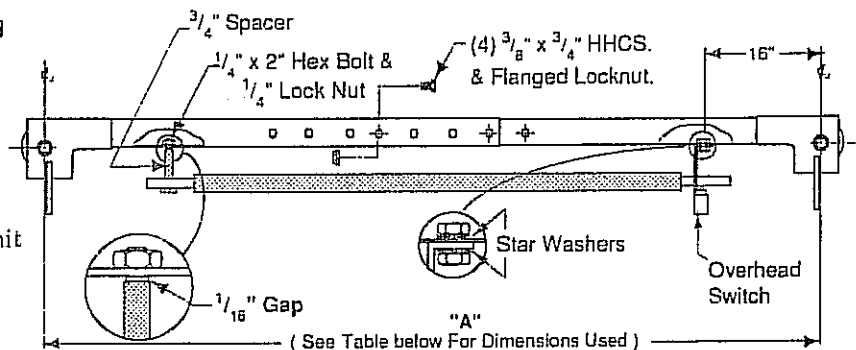

Determine Which Holes To Use By Using Table and Illustration Below. Identification Letters Are Stamped Into Top of Each Overhead Section.

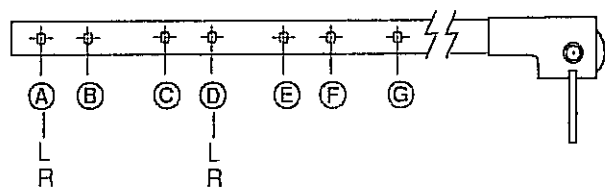

Dimension "A"	Models	Holes Used Right Side	Holes Used Left Side
114" Std.	WO9	A & D	A & D

8. Install crosshead assembly to column extensions with (8) 3/8" x 1" lg. Hex Cap Screw and Flanged Locknuts, Fig. 4. Tighten bolts at center of crosshead assembly.

**9. Power Unit:** First install (1) star washer onto one of the (4)  $\frac{5}{16}$ " x  $\frac{3}{4}$ " Lg. bolts. **This is very important for grounding.** Put the (4)  $\frac{5}{16}$ " x  $\frac{3}{4}$ " lg. bolts thru holes in power unit bracket using push-nuts to hold in place. Mount unit with motor up to column bracket and install lock washers and nuts. Install and hand tighten Branch Tee to pump until O-ring is seated. Then tighten locknut to 35-40 ft.-lbs, and connect supply hoses to Tee, Fig. 7.

**Note:** Overtightening locknut may tear O-ring.

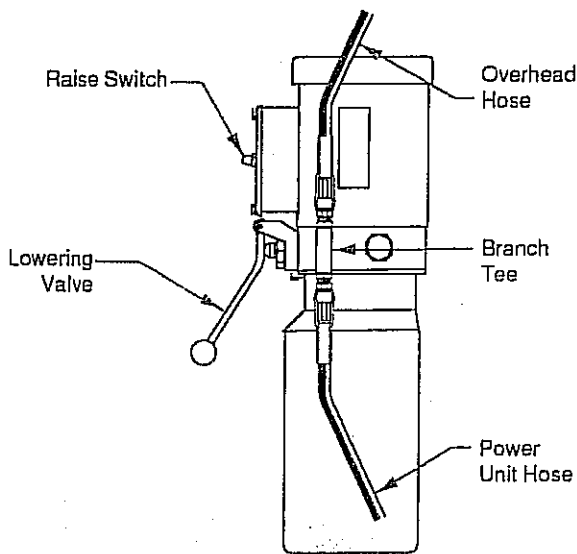

Fig. 7

Install enclosed capacity label on power unit, Fig. 8.

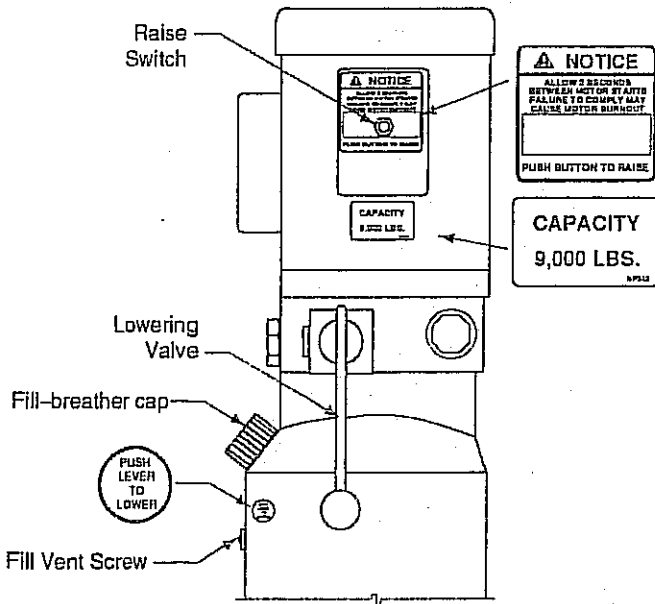

Fig. 8

**10. Hoses:** Clean adapters and hose. Inspect all threads for damage. Install hose and hose clamps, Fig. 9.

**Adapter & Hose Installation**

1. Install Pc (2) with hose clamps, on power unit column side connecting it to the cylinder (1) first.
2. Install Pc (3) with hose clamps starting at left column cylinder (5) and working toward the right column. All excess hose should be at bends & inside Crosshead Assembly.
3. Install Pc (4) into power unit.
4. Connect Pc (2) & Pc (3) to tee (4).

**Note:** Route Power Unit hose inside columns using slots provided at column base, (A). Route Overhead Hose in column channel on outside of column, (B). Overhead hose goes over top end of overhead assembly, and Locking Latch cable routes between the sheaves, (C).

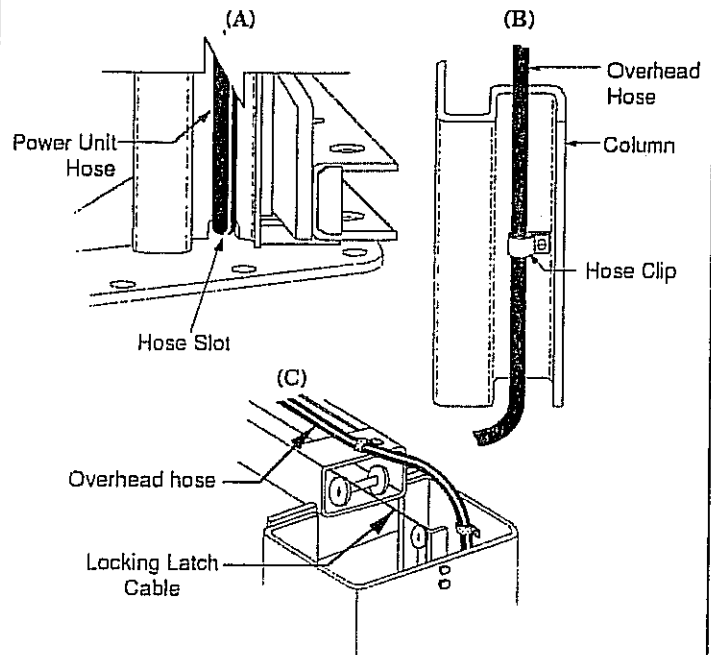

**Note:** Overhead Hose crosses and runs down approach side of left column to cylinder.

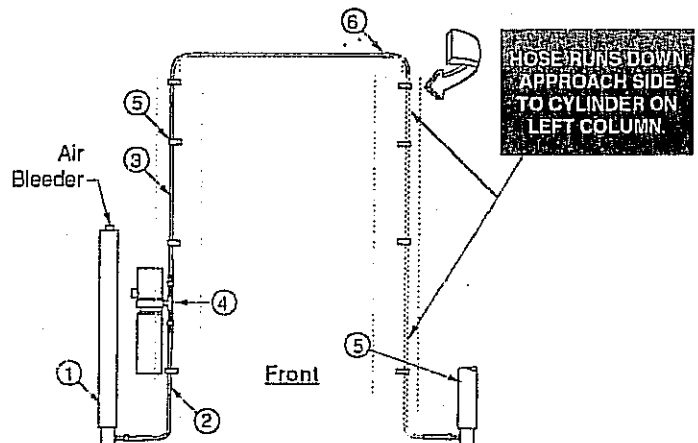

\* Items pre-assembled at factory

ITEM	QTY.	DESCRIPTION
1	2	Hydraulic Cylinder
2	1	FJ837 Power Unit Hose
3	1	FJ839 Overhead Hose
4	1	FJ7668 Branch Tee
5	6	FJ7499 Hose Clips
5	6	$\frac{5}{16}$ "-18NC x $\frac{3}{8}$ "lg. slotted PHMS
6	4	FJ7206 Hose Clips
6	4	#10-24NC x $\frac{3}{8}$ " lg. slotted HHTS

Fig. 9

11. **Equalizing Cables:** Fig. 10 describes general cable arrangement. It's easier to tie off lower studs first. Run cable stud up thru the lower tie off plate, and bracket(s) depending on lift model, using  $\frac{9}{16}$ " hole. Push cable up until stud is above top of carriage tube. Run nylon insert locknuts onto studs so that  $\frac{1}{2}$ " extends out from top of locknut, then pull cable back down, Fig. 10. Run cable overhead and tie off top studs torquing to about 10 ft.-lbs.

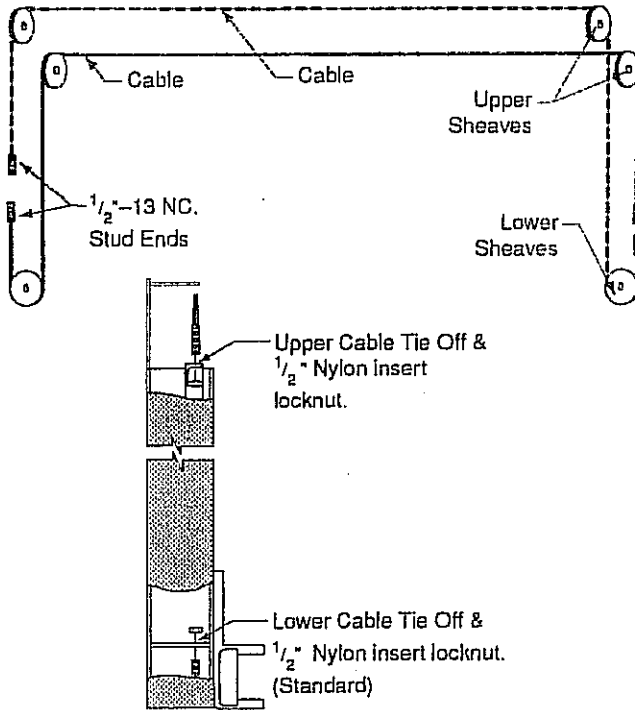

Fig. 10

12. **Latch Cable:** Lower both carriages down so that the top of each carriage is below the latch cable sheave slot. Slip loop end of cable over end of shoulder bolt on right side latch control plate, Fig. 11. Feed the other end of the cable through the slot making sure that the cable is running under the bottom side of the sheave, Fig. 11, and inside the right column. Route cable inside column and over the top of the upper sheave, Fig. 12. Continue routing cable to the left column upper sheave, Fig. 12 & Fig. 9 (C), making sure the cable goes over the top of the upper left column sheave. Note how cable goes between the equalizer cable sheaves. Bring the cable down inside the left column and feed the end of the cable through the sheave slot so that the cable is now back outside the column, Fig. 13. Route cable under the bottom side of the sheave. **At this point you MUST install the right column latch cover Fig. 14, and latch Handle Fig. 11, then continue.** Insert cable up through cable clamp, loop around shoulder bolt and

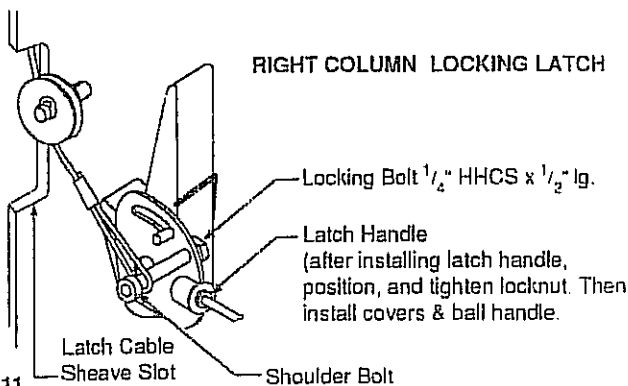

Fig. 11

back down through the clamp. Next, pull the Control Plate down, Fig. 13, to eliminate any clearance between the Control Plate slot and the Latch Dog pin (making sure the Latch Dog itself does not move), also see Fig. 12, and pull cable snug to remove any excessive slack and wrench tighten clamp, Fig. 13. When raising, listen to latches to be sure that both latch dogs fall into latch slots. If they do not, Loosen clamp and adjust tension as necessary. When latches are adjusted to desired tension, hold clamp with pliers and tighten clamp securely. See Fig. 14 & "Locking Latch Adjustments" below for further adjustment procedures. Recheck, make sure cable is properly routed through sheaves. Then install left latch cover Fig. 14.

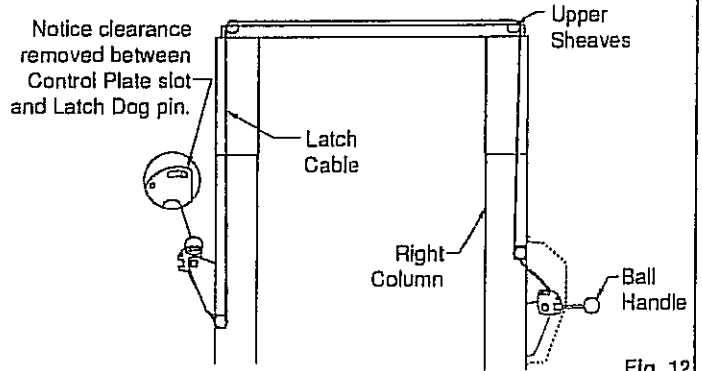

Fig. 12

**LEFT COLUMN LOCKING LATCH**

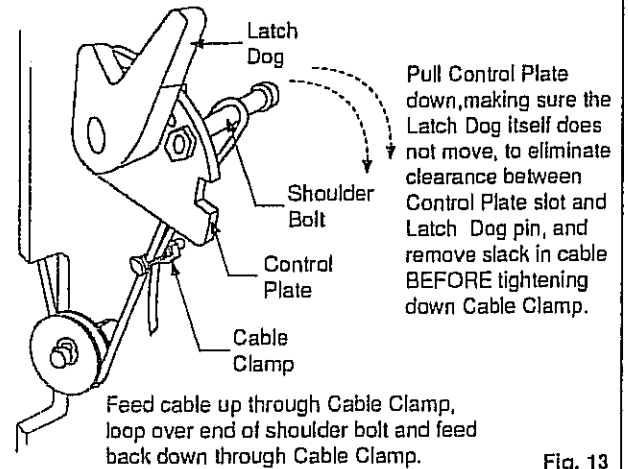

Fig. 13

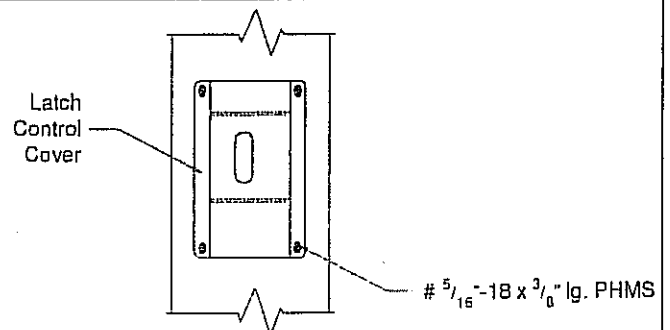

Fig. 14

**Locking Latch Adjustment:**

1. Raise carriages past the first latch position and then lower onto latches.
2. Check that the latches have fully engaged when the latch handle is released. Be sure carriage is resting on latch dog.
3. Raise carriages fully off latches, push latch handle and check that the latches have fully disengaged.
4. Make necessary adjustments if required, see Fig. 13, recheck latch function.

**13. Overhead switch:** Check overhead switch assembly to assure that switch bar is depressing switch plunger sufficiently to actuate the switch. The overhead switch is wired normally open, see Fig 15. Lift will not operate until weight of switch bar is depressing switch plunger.

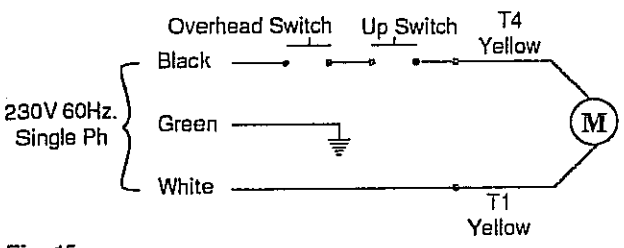

Fig. 15

**14. Electrical:** Have a certified electrician run 208-230 volt single phase 60Hz. power supply to motor Fig. 15&16. Size wire for 25 amp circuit. See Motor Operating Data Table.

**IMPORTANT**

Use separate circuit for each power unit. Protect each circuit with time delay fuse or circuit breaker. For single phase 208-230V, use 25 amp fuse, and three phase use 15 amp fuse. For three phase 460V, use 8.75 amp fuse. For three phase wiring see Fig. 16 b. Wiring must comply with all local electrical codes.

**Note:** Motor CAN NOT Be Run On 50Hz. Line Without A Physical Change In The Motor.

MOTOR OPERATING DATA - SINGLE PHASE		
LINE VOLTAGE	60 HZ	RUNNING MOTOR VOLTAGE RANGE
208 - 230 Volts	60 HZ	197 - 253 Volts

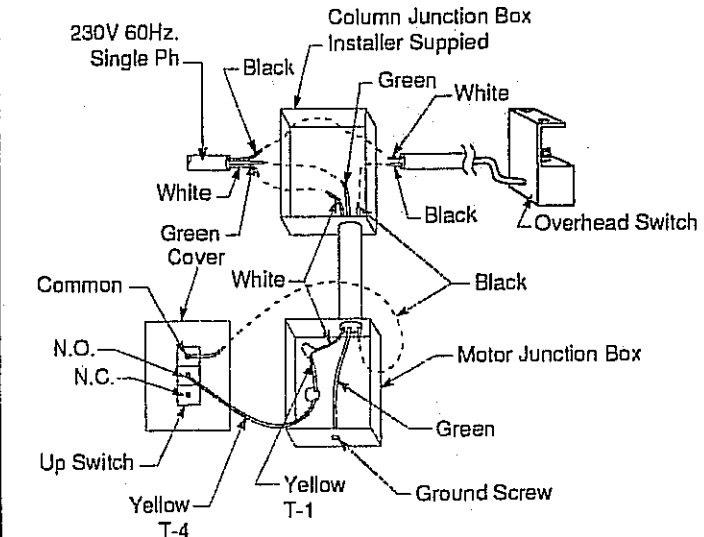

Fig. 16 a

MOTOR OPERATING DATA - THREE PHASE			
LINE VOLTAGE	60 HZ	RUNNING MOTOR VOLTAGE RANGE	
208 - 230 Volts	60 HZ	197	- 253 Volts
460 Volts	60 HZ	414	- 506 Volts

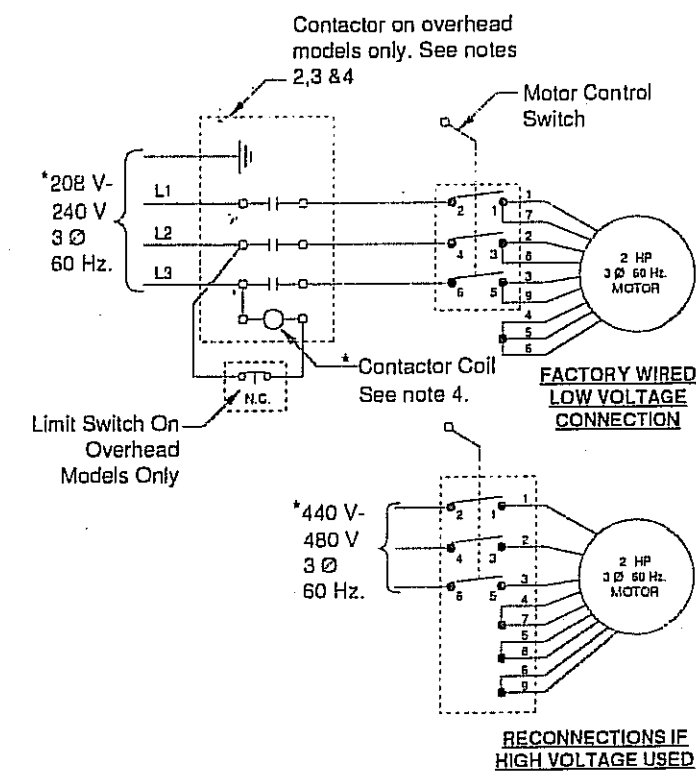

Fig. 16 b

**NOTES:**

- 1.) Unit not suitable for use in unusual conditions. Contact Rotary for moisture and dust environment duty unit.
- 2.) Contactor must be field mounted on power unit column in place of junction box.
- 3.) Contactor Requirements:  
Use:  
AB500-AAA93 (Allen-Bradley) for 220-240V Supply  
AB500-AAH93 (Allen-Bradley) for 208 Supply  
AB500-AAB93 (Allen-Bradley) for 440-480V Supply
- 4.) \* Verify Coil Rating Matches Supply Voltage
- 5.) Motor rotation is counter clockwise from top of motor.

**15. Oil Filling & Bleeding:** Use Dexron II ATF. Remove fill-breather cap and fill vent screw, Fig. 8. Pour in (8) quarts of fluid. Start unit, raise lift about 2 ft. Open cylinder bleeders approx. 2 turns, Fig. 9. Close when fluid streams. Fully lower lift. Add more fluid until it comes out fill vent hole. System capacity is (13) quarts. Replace fill vent screw and fill-breather.

**CAUTION**

If fill-breather cap is lost or broken, order replacement. DO NOT substitute with a solid plug. Can cause pressure to build up in reservoir.

**Note:** When bleeding cylinders equipped with Allen Head Set Screw in center of Hex plug, only turn the Set Screw in center of Hex plug to bleed. When doing so, Hex plug will need to be held in place while loosening Set Screw.

16. **Wheel Spotting Dish:** Position wheel spotting dish as illustrated in Fig. 17. Drill (2)  $\frac{3}{8}$ " holes  $2\frac{1}{2}$ " deep in concrete floor using holes in wheel spotting dish as guide. Drive both anchors, provided, into concrete to secure dish.

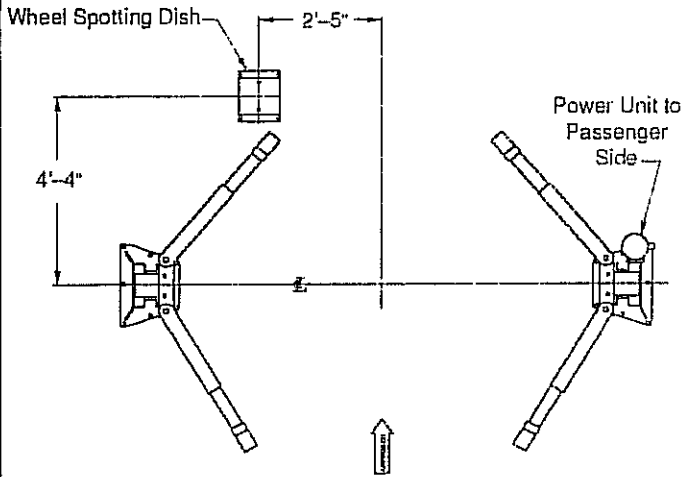
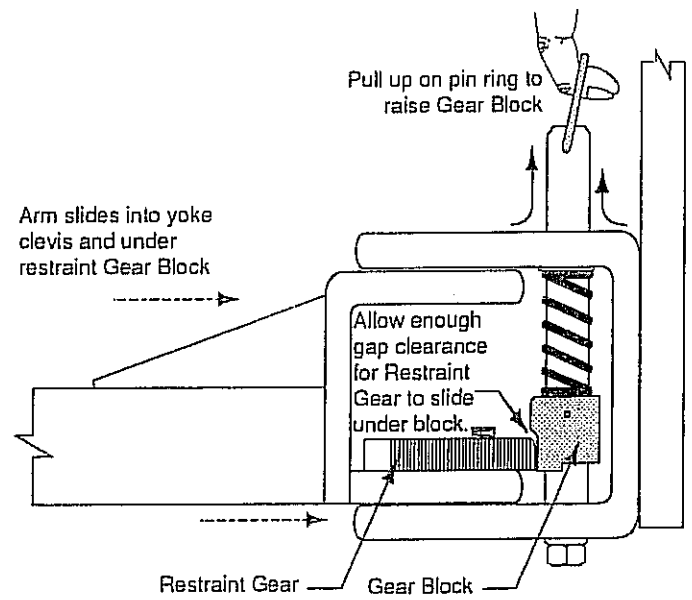

Fig. 17

17. **Arm Restraints & Superstructure:**

Before installing arms, install arm Restraint Gears as follows. Install Restraint Gear into arm clevis, as shown in Fig. 18, so that the rounded edge (top side) of the gear teeth is facing upward. Then, install the three (3)  $\frac{3}{8}$ "-16NC x  $1\frac{1}{2}$ " Lg. HHCS (12 total for all 4 arms) and  $\frac{3}{8}$ " Spring Lockwashers into the gear and arm as illustrated Fig. 18, but do not tighten. Front arm gears are shown, rear arm gears install the same.

After installing Restraint Gears, raise carriages to a convenient height. Grease swivel arm pins and holes with Lithium grease. Raise Gear Block by pulling upward on pin-ring to allow enough clearance for the Restraint Gear and arm to slide into the yoke clevis and under the teeth of the Gear Block (or gear stop), Fig. 19. Install  $1\frac{1}{2}$ " diameter arm pin(s) and  $\frac{3}{16}$ " x 2" cotter pin(s), Fig. 20. After installing arm pin, torque the three Restraint Gear bolts to 30-34 ft.-lbs. Let the Gear Block down allowing the teeth of the Restraint Gear and Gear Block to mesh together, Fig. 19.



Note: Pin & Ring, Spring and Gear Block are pre-assembled.

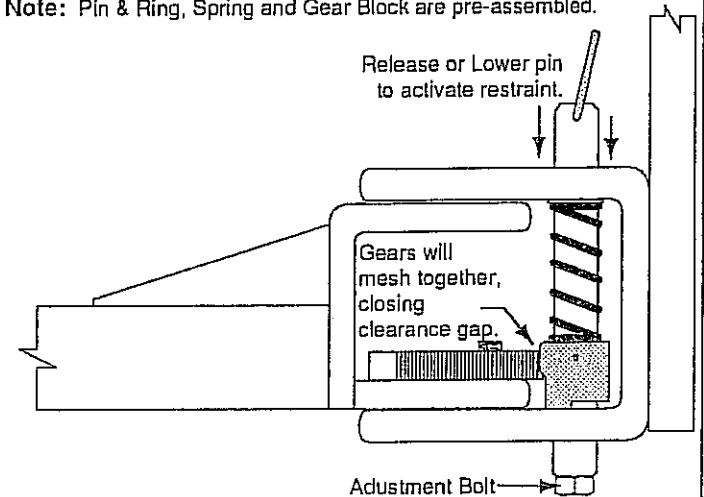

Fig. 19

Note: To check operation of arm restraints, raise carriage 1" min. from full down position. Pull up on pin-ring and adjust arms to desired position. To engage restraint, let pin-ring down allowing gear teeth to mesh together. It may be necessary to rotate arm slightly to engage gear teeth. If restraints do not disengage when carriage is in full down position, remove adjustment bolt on bottom of pin, add washers to desired height and replace. See Fig. 19. Recheck operation.

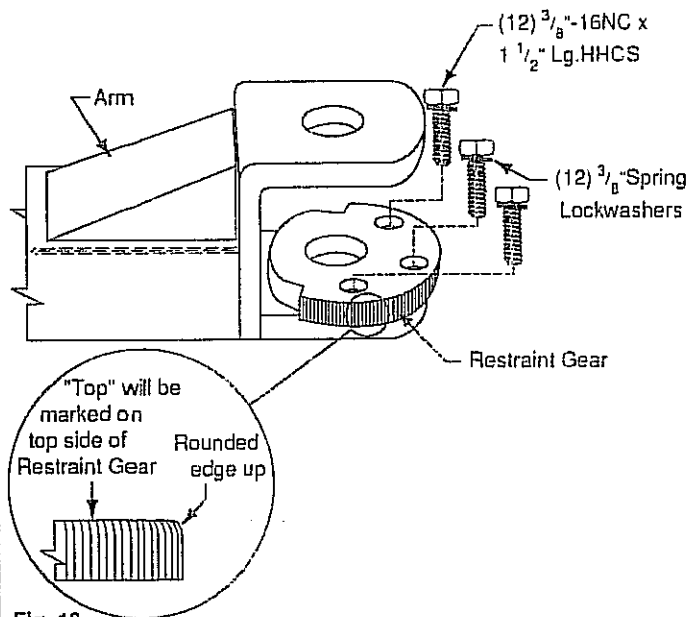

Fig. 18

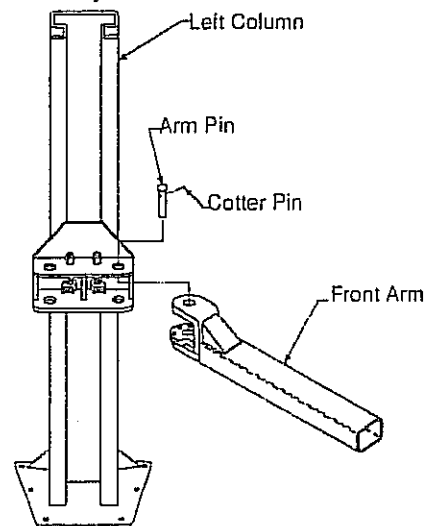

Fig. 20

**18. Door Bumper Installation:**

- 1) Press long bumper on column edge, Fig. 21.
- 2) Press short bumper on top edge of carriage tube, Fig. 21.

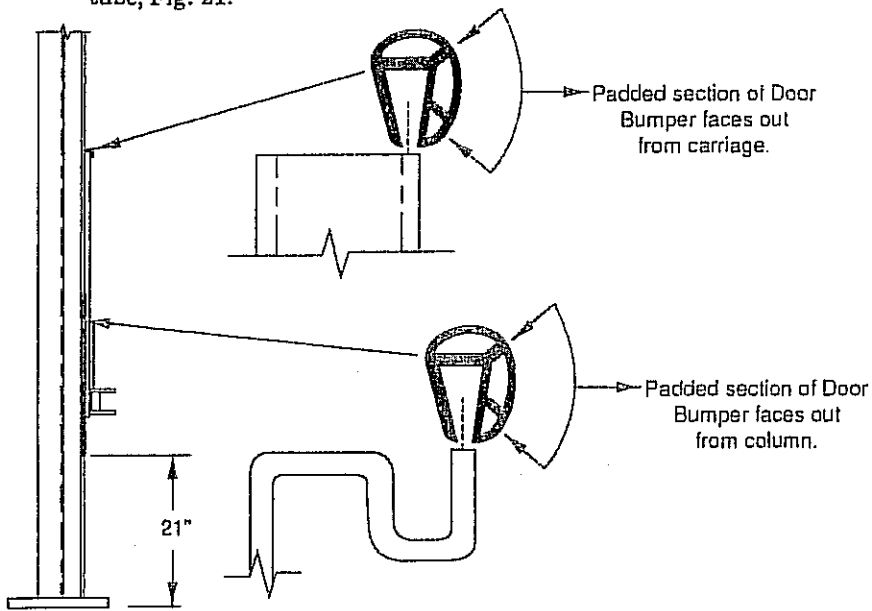

Fig. 21

**19. Pressure Test:** Run lift to full rise and keep motor running for 5 seconds. Stop and check all and hose connections. Tighten or reseal if required. Repeat air bleeding of cylinders.

**20. Final Adjustments:** Raise lift to check equalizer cable tension. Below carriage, grasp adjacent cables between thumb and forefinger, with about 15 lbs. effort you should just pull the cables together. Adjust at upper tie-offs Fig. 22.

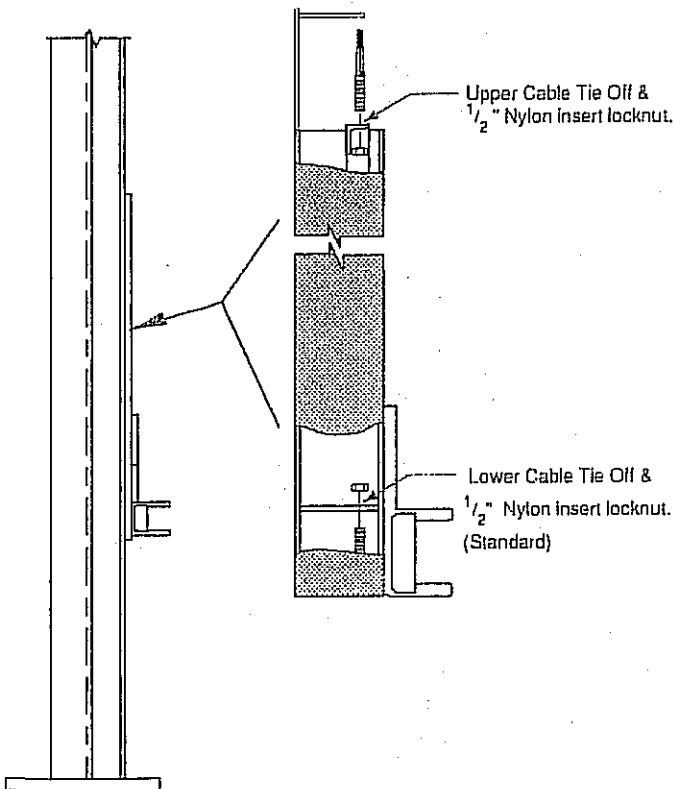

Fig. 22

21. If latch release decal is not already installed, then install on right column (or power unit side) cover, Fig. 23.

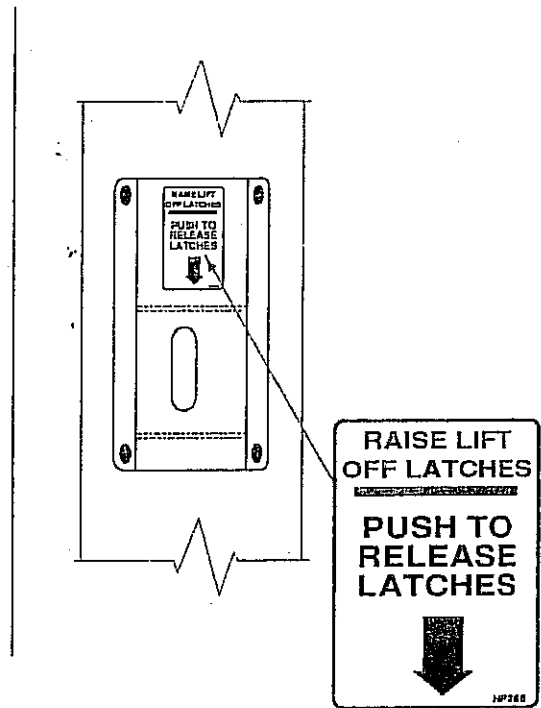

Fig. 23

**22. Decal Location:** Install enclosed pinch point decals. Place (1) decal on each column, Fig. 24.

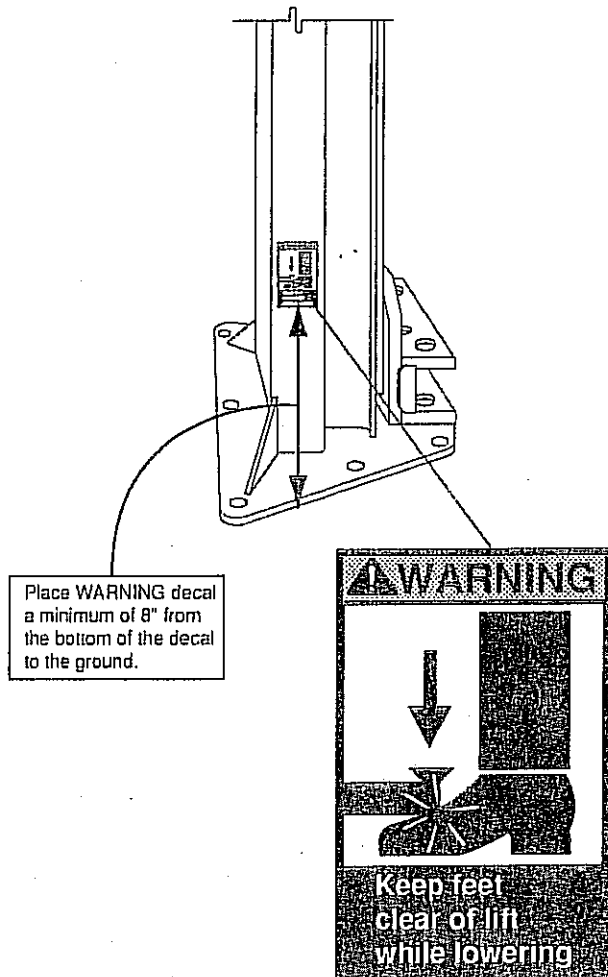

Fig. 24



## ROTARY IDENTIFICATION

At Completion of Installation, Place ROTARY Decal on  
Lift as Shown Below

**Decal Location:** Clean area where decals are to be placed. Remove backing from decals. Position and apply on approach sides of each column indicated, Fig.25, and press flat.

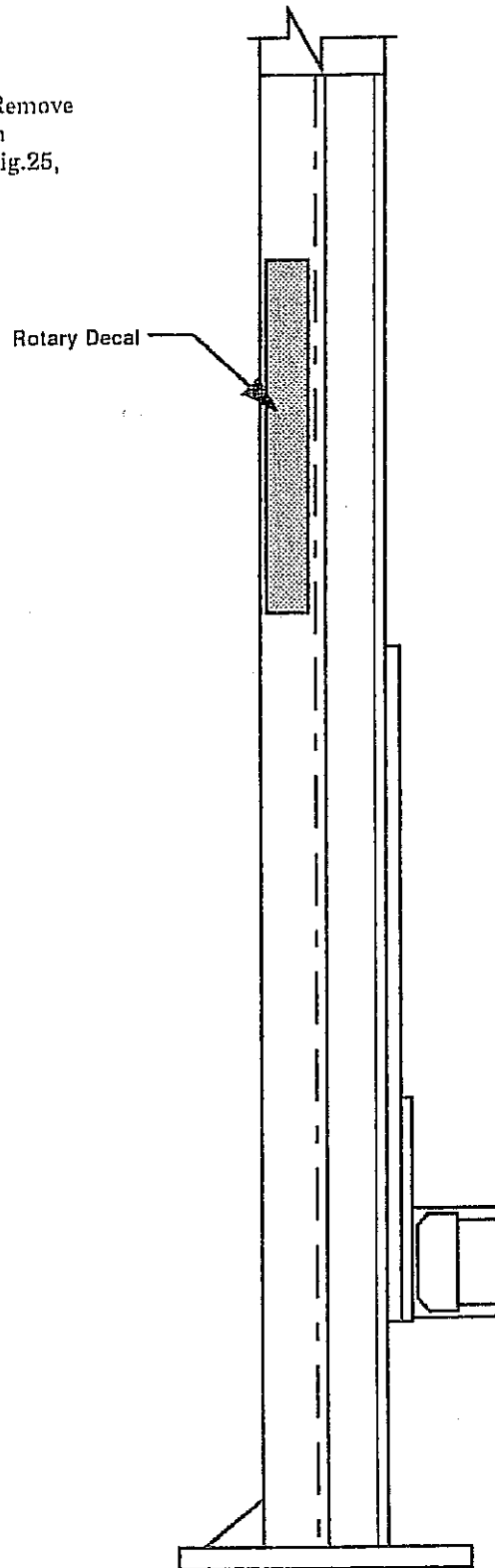

# ROTARY LIFT

P.O. Box 1560 Madison, IN. 47250  
 WORLD LEADER IN LIFT SYSTEMS

A **DOVER** INDUSTRIES COMPANY

# MODEL: WO9

(For WO9-100 to -199 Lifts)

## PARTS BREAKDOWN

(Non-Seismic Lift)

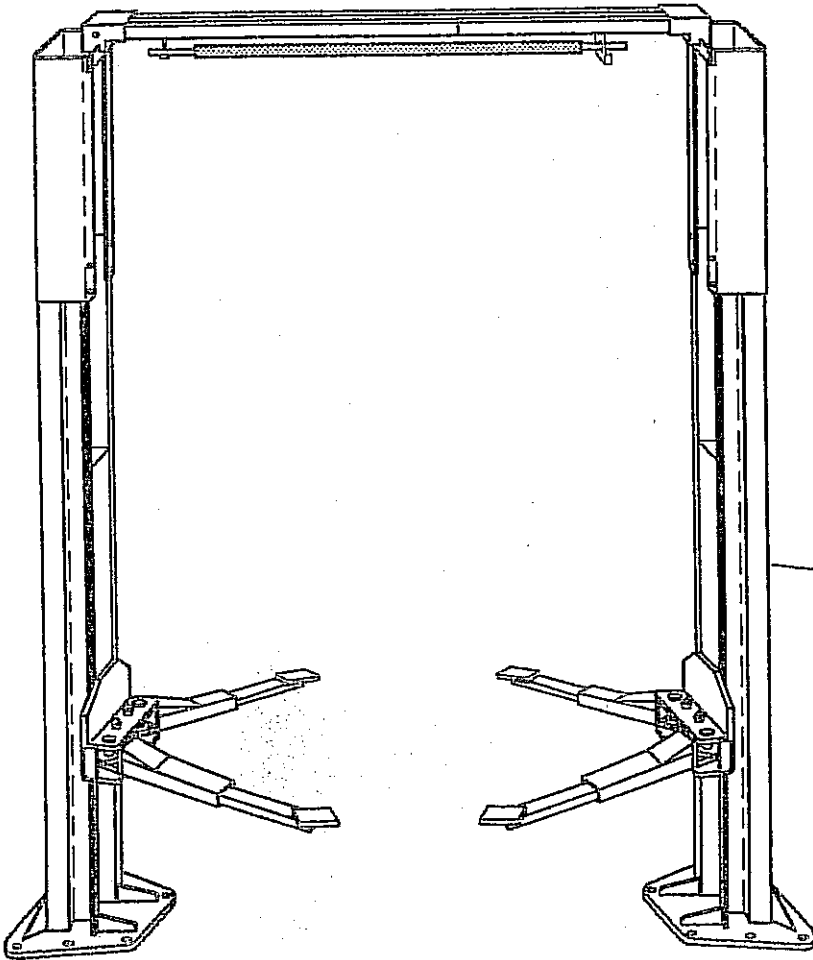

ETL Listed

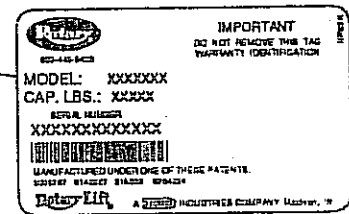

**IMPORTANT:** When ordering parts or requesting service always give exact model and power unit serial number. Model number is shown on nameplate attached to base of Power Unit column. Power unit serial number is located on side of power unit reservoir.

### NOTES:

- New power unit models are now being used. Models are as follows:  
 WO9 single phase = P702 replaced previous model P602.  
 WO9 three phase = P704 replaced previous model P604.

### OWNERS RECORD

Complete information at right and keep in a safe place.

Date Installed \_\_\_\_\_ / \_\_\_\_\_ / \_\_\_\_\_

Installed In Bay # \_\_\_\_\_

Std. Pwr. Unit Serial # \_\_\_\_\_ Model # \_\_\_\_\_

3 ph. Pwr. Unit Serial # \_\_\_\_\_ Model # \_\_\_\_\_

Lift Serial # \_\_\_\_\_

Model No# \_\_\_\_\_

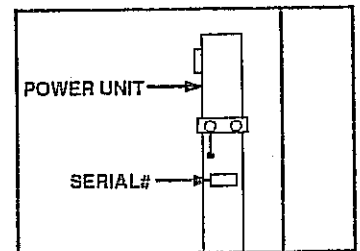

**NOTE: For Replacement Parts - See Your Nearest Rotary Lift Parts Distributor**

## WO9 PARTS LIST

ITEM NO.	DESCRIPTION	PART NO.	ITEM NO.	DESCRIPTION	PART NO.	
1	L.H. Column Weldment	N75	35 †	Adjustment Bolts & Washers	†	
2	R.H. Column Weldment	N76	36	Gear Bolts $\frac{3}{8}$ "-16NC x 1 $\frac{1}{2}$ " HHCS Grade 5	40200	
3	Column Extension	N45				
4	Carriage Yoke Weldment	N86	37	$\frac{3}{8}$ " Spring Washers	40818	
5	Outer Arm	FJ7772-1	38	Restraint Gear	FJ7750	
6	Outer Arm	FJ7772-1	39	Slider Block	FJ7360	
7	Hydraulic Cylinder	FJ7664	40	$\frac{3}{4}$ " Concrete Anchor (14 Req'd)	FJ7380	
8	Power Unit	See "Notes" On Front Cover		41	1 $\frac{1}{2}$ " O.D. x .760-.770" I.D. x .045" Thick Mach. Bushing	41388
9	Power Unit Hose	FJ837	42	$\frac{1}{4}$ "-20NC x 2" HHCS	40109	
10	$\frac{5}{16}$ "-18NC x $\frac{3}{4}$ " Bolt, Ext Tooth LW&Nut	40224	43	$\frac{1}{4}$ " — 20NC Insert Lock Nut	41423	
11	Inner Arm	FJ7416-2	44	$\frac{1}{8}$ " x 1" Lg. Cotter Pin	41200	
12	$\frac{3}{8}$ " 16NC x $\frac{5}{8}$ " Lg. HHCS Gr.8	40155	45 @@	Limit Switch Assembly	FJ7613 @@	
13	$\frac{3}{8}$ " Internal Tooth Lockwasher	40843	46	Switch Bar Assembly	FJ7613-2	
14	Order with Complete Ass'y item #11	FJ7416-2	47	R.H. Latch Sheave Bracket Assy	FJ7767	
15	High Step Adapter	FJ671-1	48	R.H. Overhead Weldment	N44-1	
16	Low Step Adapter	FJ671-2	49	$\frac{3}{8}$ " — 16NC x $\frac{3}{4}$ " Long HHCS	40134	
17	Adapter Pin	FJ671-3	50	$\frac{3}{8}$ " Flat Washer	40820	
18	$\frac{3}{32}$ " Hog Ring For $\frac{1}{2}$ " Shaft	FJ671-6	51	Overhead Hose	FJ839	
19	Adapter Swivel Pin	FJ79-6	52	Equalizer Cable Assembly	FJ7450	
20	Bleeder Screw MF (specify manufacturer)	2 REQ'D	53	L.H. Overhead Weldment	N43-1	
21	Carriage Bumper	FJ7391-2	54	Locking Latch Cable Assembly	FJ7594-1	
22	Arm Pin	FJ7838	55	$\frac{3}{8}$ " — 16NC x 1" Flanged HHCS	40144	
23	Approach Bumper (Door-18" Lg-2 Req'd)	FJ7391-1	56	$\frac{3}{8}$ " — 16NC Flanged Locknut	40664	
24	$\frac{1}{2}$ " — 18NC Hex Lock Nut	40703	57	Sheave Shaft	FJ7444-8	
25	$\frac{3}{16}$ " x 2" Long Cotter Pin	41250	58	Bracket	FJ7613-1	
26	Truarc #5304-75 Klipping for $\frac{3}{4}$ " Shaft	41411	59	$\frac{1}{4}$ "-20NC x $\frac{3}{4}$ " HHCS Grade 5	40104	
27	Sheave	FJ7116-1	60	L.H. Latch Sheave Bracket Assy	FJ7766	
28	Wheel Spotting Dish Kit	FF729	61	Locking Latch Sheave	FJ7322	
29	Actuator Pin Handle	FJ7985-1	62	Truarc Klip #5304-37 for $\frac{3}{8}$ " Shaft	41410	
30	Actuator Pin	FJ7656-1	63	Hose Clip (4 Req'd)-Overhead	FJ7206	
31	Retaining Ring	FJ7646-2	64	#10 — 24NC x $\frac{3}{8}$ " Lg. Slotted HHTS (For Overhead)	40033	
32	Arm Restraint Spring	FJ7656-2		$\frac{5}{16}$ " — 18NC x $\frac{3}{8}$ " Lg. Slotted PHMS (For Columns)	40227	
33	120T Gear Block	FJ7749	65	Branch Tee	FJ7668	
34	Spring Pin, $\frac{1}{4}$ " dia. x 1 $\frac{1}{2}$ " Lg. (stainless)	14427	66	Hose Clip, Column, 6 Req'd	FJ7499	
34b	$\frac{1}{4}$ "-20NC Zinc Hex Nut	40627	67	$\frac{3}{8}$ "-16NC x $\frac{3}{8}$ " Lg. Flanged HHCS	40122	
34c	Sheave Cover	N119-1	68	$\frac{1}{4}$ " - 20NC Flanged Locknut	40641	
34d	$\frac{1}{4}$ "-20NC PHMS x $\frac{3}{8}$ " Lg. Plated (2pcs.)	40063	69	$\frac{3}{4}$ " Spacer	FJ7871	
			70 @@	3 Phase Limit Switch Assy. For Units Using Above 250V.	FJ7979	
			71	Single Phase Limit Switch (only)	P461-2	
			72 ▲	Three Phase Limit Switch (only)	FJ7979-1	
			73	Limit Switch Bracket Cover	FJ7979-2	
			74	$\frac{1}{4}$ " External Tooth Lockwasher	40779	
			75	$\frac{3}{8}$ " External Tooth Lockwasher	40845	
			76 **	Arm Restraint Kit (1 Arm)	FJ7888	

Wheel Spotting Dish

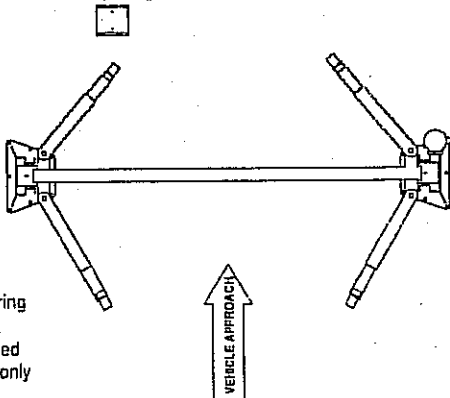

† Adjustment bolt, spring washer(s) and SAE washer(s) determined at assembly. Used only if required.

Bolt - 5/16"-18NC x 5/8" Lg. SHCS  
Spring Lock Washer - .078" thick  
SAE Washer - 11/32" I.D. x 11/16" O.D. x 1/16" thick

\*\*\* Includes item No#'s 29, 30, 31, 32, 33, 34, 35, 36, 37 & 38

@@ Includes item 58, 73 & 74

▲ For units using above 250V. 250V and lower use P461-2 switch.

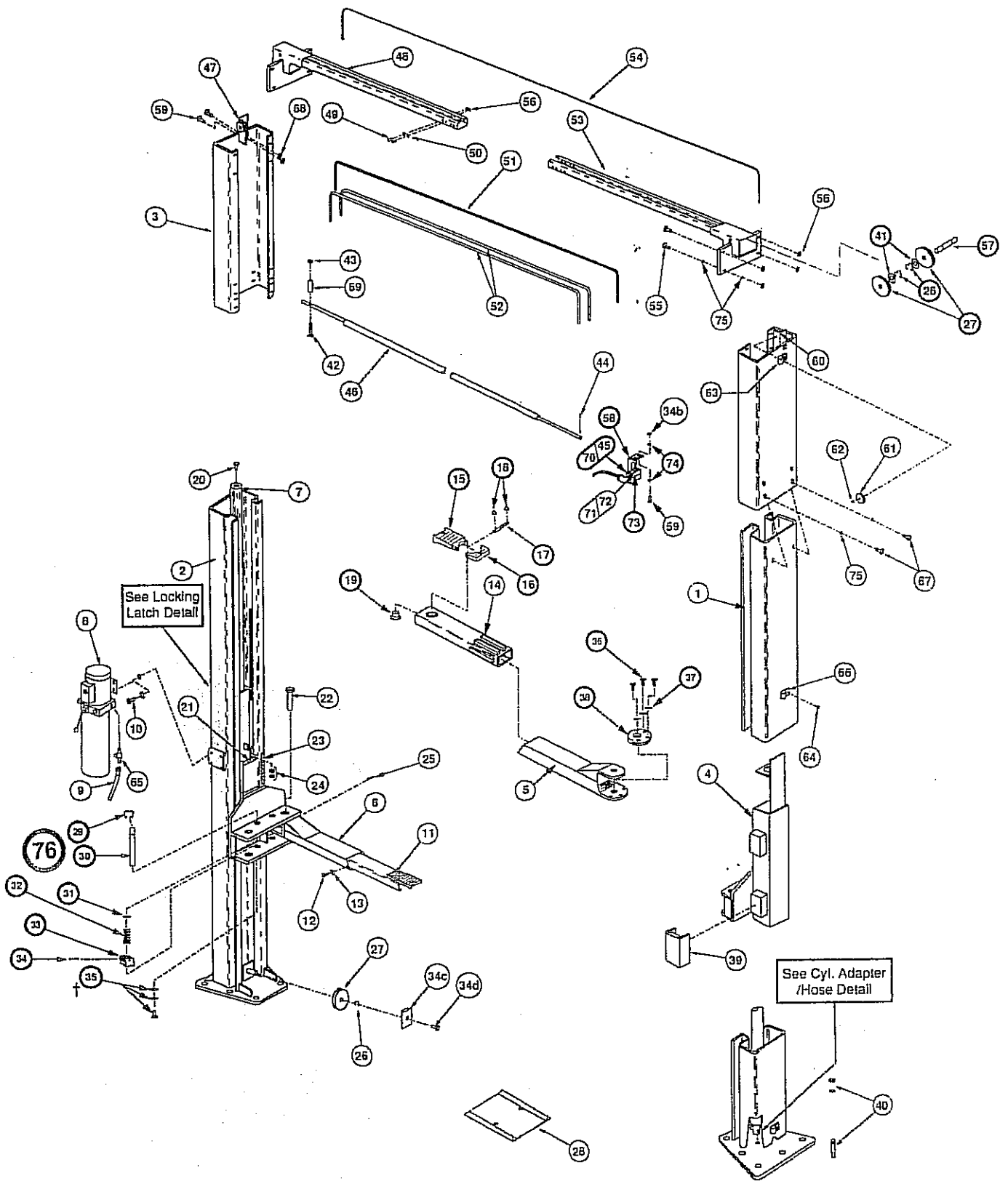

For Extended Height Models Use Part Numbers Below As Cross Reference, All Other Parts Are Common

	#3-Column Extensions	#55-Overhead Hose	#56-Equalizer Cables	#58-Locking Latch Cable
WO9 EH-1	N46	FJ842	FJ7547	FJ7595-1
WO9 EH-2	N47	FJ843	FJ7528	FJ7595-1

# CYLINDER ADAPTER / HOSE DETAIL

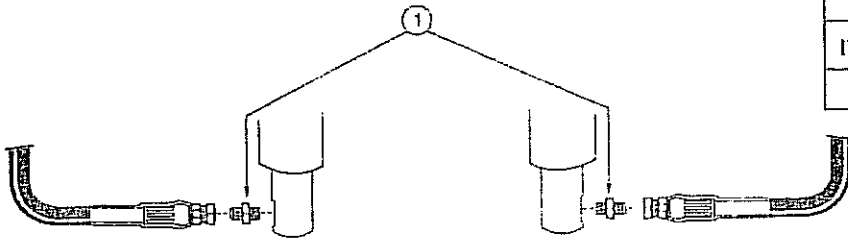

CYLINDER ADAPTER/HOSE DETAIL PARTS LIST		
ITEM NO.	DESCRIPTION	PART NO.
1	Straight Adapter	FJ7352-3

## RIGHT COLUMN

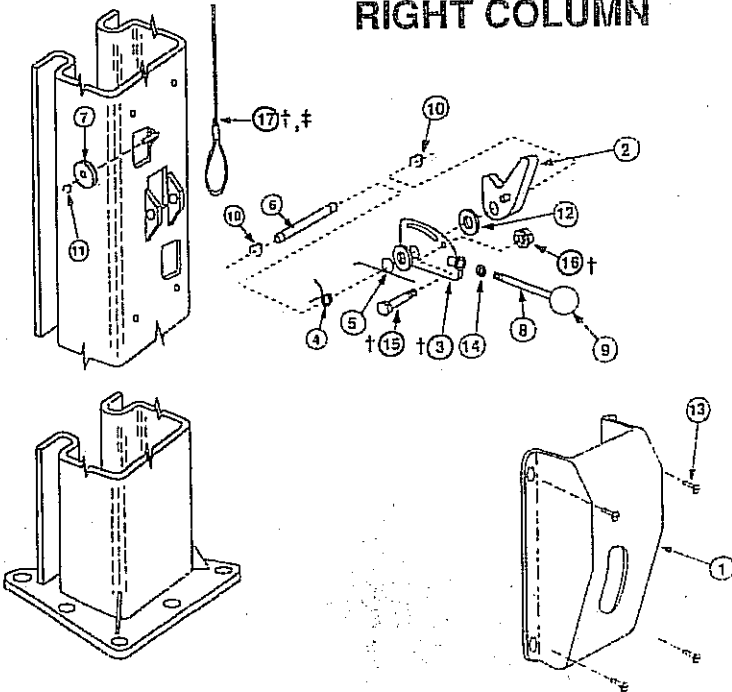

LOCKING LATCH DETAIL PARTS LIST		
ITEM NO.	DESCRIPTION	PART NO.
1	Control Side Cover	FJ7452
2	Locking Latch Dog	FJ7382-7
3	Control Plate	FJ7594-2
4	Spring	FJ7382-2
5	Spring	FJ7382-9
6	Latch Shaft	FJ7382-3
7	Locking Latch Sheave	FJ7322
8	Handle	FJ7382-18
9	Ball Handle	FC134-91
10	Truarc Klipring #5304-75 for $\frac{3}{4}$ " Shaft	41411
11	Truarc Klipring #5304-37 for $\frac{3}{8}$ " Shaft	41410
12	1 $\frac{1}{2}$ " O.D. x $\frac{3}{4}$ " I.D. x .045" Mach. Bush.	41388
13	$\frac{5}{16}$ " - 18NC x $\frac{3}{8}$ " Lg. Slotted Pan Hd. Screw	40227
14	$\frac{3}{8}$ " - 16NC Hex Jam Nut	40658
15 †	Shoulder Bolt, $\frac{5}{16}$ " x 1" - $\frac{1}{4}$ " 20 NC	40220
16 †	Flanged Locknut, $\frac{1}{4}$ " - 20 NC	41423
17 †	Latch Cable	FJ7594-1
‡	For EH-1 & EH-2 Model SPO9	FJ7595-1

† - Locking Latch Retrofit Kit FJ7594; FJ7595 (EH-1 & 2)  
Includes: 1 pc. #3, 1 pc. #17, 2 pcs. #15, 2 pcs #16,  
1 pc. #3 (left side below), 1 pc. #15 (left side below)

## LEFT COLUMN

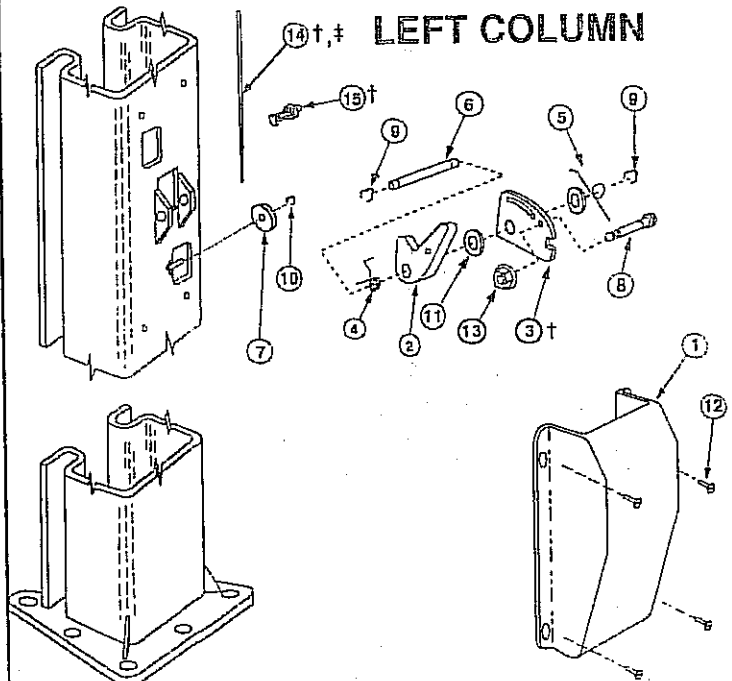

LOCKING LATCH DETAIL PARTS LIST		
ITEM NO.	DESCRIPTION	PART NO.
1	Latch Cover	FJ7451
2	Locking Latch Dog	FJ7382-7
3†	Control Plate	FJ7382-5
4	Spring	FJ7382-2
5	Spring	FJ7382-9
6	Latch Shaft	FJ7382-3
7	Locking Latch Sheave	FJ7322
8	Shoulder Bolt $\frac{5}{16}$ " x 1" - $\frac{1}{4}$ "-20NC	40220
9	Truarc Klipring #5304-75 for $\frac{3}{4}$ " Shaft	41411
10	Truarc Klipring #5304-37 for $\frac{3}{8}$ " Shaft	41410
11	1 $\frac{1}{2}$ " O.D. x $\frac{3}{4}$ " I.D. x .045" Mach. Bush.	41388
12	$\frac{5}{16}$ " - 18NC x $\frac{3}{8}$ " Lg. Slotted Pan Hd. Screw	40227
13	Flanged Locknut, $\frac{1}{4}$ " - 20 NC	41423
14	Latch Cable	FJ7594-1
15	Latch Cable Clamp (BURNDY)	KS-15
‡	For EH-1 & EH-2 Model SPO9	FJ7595-1

† Locking Latch Retrofit Kit FJ7594; FJ7595 (EH-1 & 2)  
(see Right Column for items included)

**Rotary Lift**®

ROTARY LIFT  
A Dover Industries Company  
P.O. Box 1560  
Madison, Indiana 47250-0560  
Phone toll-free: 1-800-445-LIFT (5438)  
(812) 273-1622  
FAX: (800) 822-6502

For Export  
ROTARY LIFT EXPORT  
COMPANY  
200 Executive Drive, Suite 320  
West Orange, NJ 07052  
(201) 325-3535  
Telex # 13-8693  
FAX: (201) 325-7974

For Canada:  
DOVER CORPORATION CANADA -  
ROTARY LIFT DIVISION  
130 Bridgeland Avenue, Unit 210  
Toronto, Ontario, Canada M6A 1Z4  
(416) 256-4100  
FAX: (416) 256-3924

INDEX 2.52.24

New Gen I