

HERO

INNOVATIVE **COLOR** TECHNOLOGY

Manual Colorant Dispenser D23 Series

2.5 Quart (2.3 Liter) Polymer Nylon Canisters

2 Oz (60 ml) Maximum Dispense Pumps

Equipped with Standard or Micro Gauges™ for fractional increment dispensing

Ergonomically designed valve handles

Modular stand for easy conversion from countertop to floorstand

Automatic electric time controlled bottom agitation

Floor Stand



Countertop

SAFETY AND OPERATING MANUAL



**WARNING: DO NOT OPERATE THIS EQUIPMENT WITHOUT READING
AND UNDERSTANDING ALL SAFETY AND OPERATING INSTRUCTIONS**



I.C.T.C. Holdings Corporation:
720 Eaton Way
Delta, B.C., Canada
V3M 6J9

U.S.A Mailing Address:
P.O. BOX 75
Custer, WA
98240-0075

PHONE: (604) 522-6543

FAX: (604) 522-8735

TOLL FREE: (800) 494-4376

Model D23PRM/PRM

TABLE OF CONTENTS

For greater user satisfaction, please familiarize yourself with all maintenance and operating instructions.

Introduction	3
Unpacking	3
Assembly Instructions	4 - 5
Dispenser Preparation	6
Tinting Instructions	6 - 7
Maintenance Instructions	8
Trouble shooting	9
Problem Solving	10 - 11
Piston Seal Replacement	12 - 13
Valve Assembly Replacement	14
Re-Calibration Instructions	15 - 16
Wiring Schematic and Automatic Timer	17-18
Canister Parts List and Diagram	19 - 20
Gauges	21
Turntable and Drive Components	22
Floor stand Parts List and Diagram	23
Countertop Stand Parts List and Diagram	24 - 25

INTRODUCTION

This **HERO D23 Series Colorant Dispenser, Model D23PR/PRM** is a precision measuring device and should be treated as such. When operated and maintained in conjunction with the instructions contained within this manual, the equipment will provide a long and trouble free life. To ensure your complete satisfaction, please familiarize your self with all maintenance and operating instructions. Please keep this manual available for reference and training of new store personnel.

This unit features;

- ◆ Total Lok™ memory gauges - Only need to set the gauge once for multiple *can dispensing*
- ◆ Non magnetic stainless steel pump cylinders - *Durable, corrosive resistant*
- ◆ Long wear Teflon® Seal - *Durable, solvent resistant*
- ◆ Auto Accu-Purge Valve - *Assures clean dispensing nozzles*
- ◆ Retractable Wiper Arm - *Stops drips, keeps work area clean*
- ◆ Automatic electric time controlled bottom agitation - *Saves time, easier canister refilling*
- ◆ Stepped " Assured " agitation paddle - *Consistent thorough mixing of colorant*
- ◆ Removable Nozzles - *Various sizes of "easy clean" nozzles available*
- ◆ Nylon Polymer canister shell – *Easy clean-up*

UNPACKING

Your **HERO D23 Series Colorant Dispenser** has been carefully inspected and the pumps calibrated to measure colorant with a high degree of accuracy. It should be carefully examined upon arrival to determine that the unit shows no signs of freight damage. If any parts are found to be broken or damaged, immediately contact the carrier and arrange for an inspection of the concealed damage. Claims for damage **must** be made by you, the **consignee**, and not the shipper. The carrier accepts full responsibility for the safe delivery of merchandise upon pick-up from the shipper.

Please read all instructions before using your **HERO D23 Series Colorant Dispenser**.

COUNTER TOP MODELS (One (1) shipping carton)

Box (which contained this owners manual) contains;

- 1 x Turntable (Part # BL-3000W or 3010W)
- 1 x Drive Plate Assembly (Part # BL-2520 or 2540)
- 1 x Drive Cover (Part # BL-2050W or 2060W)
- 1 x Countertop Stand (Part # BL-3501), with attached pre-lubricated crankshaft and washer (Part # BL-2510)
- 12 x Canisters with calibrated gauges (Part # BL-1700-04, Gauges as specified on order)
- 1 x Bag containing canister mounting hardware (Part # HW30629P x 38 or 50)
- 1 x Envelop which contained this manual, plus "Lettering", if specified
- 1 x Bag containing spare parts; Three (3) nozzle o-rings (Part # BL-1192), Three (3) spare nozzles (Part # BL-1185 (S), BL-1187 (L), BL-1188 (X).
- 1 x Replacement seal set and installation tool (Part # BL-1510)

FLOOR STAND MODEL. (The shipment you have received contains two shipping cartons.)

Floor stand units shipped in two cartons. Carton one (1) contains all items listed above. Carton two contains the following;

- 1 x Floor stand (Part # BL-3770 or 3771)
- 2 x Support legs (Part # BL-3300W), c/w mounting hardware.
- 1 x Adjustable tray (Part # BL-3355 or 3359 **in with counter top box**).
- 1 x Bag containing floor stand to countertop stand mounting hardware.

Check the contents as you unpack. If any parts are missing, contact your supplier or HERO Products Group as soon as possible. Do Not commence set-up until all required parts are available.

ASSEMBLY INSTRUCTIONS

Prior to assembling your unit, prepare adequate working area to easily work with and operate your machine. For “Countertop” model, base may be placed in desired location and begin assembly procedures at step 5. For “Floor stand” model begin assembly procedures at step 1.

“DO NOT PLUG UNIT IN UNTIL ASSEMBLY IS COMPLETE.”

- 1.) Place floor stand base assembly into desired location, ensuring base is level.
- 2.) Attach support legs to base of cabinet. Support legs should extend towards the front of the cabinet and secure with screws provided.
- 3.) Place adjustable tray into shelf rails noting the arrows on the nylon guides are pointing up.
- 4.) Install the counter top assembly on to the floor stand and secure with the four screws supplied. (Install two self tapping screws in the front of the cabinet, and two in the back.)
- 5.) Remove the crankshaft and the turntable nut from the center (brass) swivel body.
- 6.) Place the turntable onto the swivel body, with the rolled edge of the turntable facing down. *NOTE; Ensure that the turntable rotates freely on the small step on the swivel and not on the threaded portion of the swivel. Brake should be engaged in the “J” slot to allow constant rotation.* Replace turntable nut and tighten.
- 7.) Install the pre-lubricated crankshaft complete with nylon washer into swivel body. Ensure the crankshaft fits completely over the motor’s square drive shaft. The motor drive shaft extends from inside the floor stand up into the center of the swivel. When positioned correctly the crankshaft will rest directly on the swivel.
- 8.) Place the drive plate onto the crankshaft, ensuring the crankshaft rotating arm is correctly located in the center bearing of drive plate. Take note of the “This side up” sticker on the drive plate. Place drive cover over the drive plate. **NOTE: Drive cover must be installed prior to mounting canisters.**
- 9.) Rotate turntable until one drive plate arm and a canister mounting location are in line with one another. Attach one canister, ensuring that the canister drive shaft is engaged in the hole of the drive plate black plastic bushing at the end of each arm.
NOTE; The drive plate turns in an oscillating pattern, rather than a circle.
- 10.) With the canister correctly positioned, secure with self tapping screws, into the three (3) holes. **DO NOT OVER TIGHTEN.** With one canister secured to the turntable, move to the position directly across from it and secure a second. See diagram on page 5. Continue mounting canisters in the order shown in illustration, rotating turntable as required.
- 11.) When all canisters are attached, gently rotate turntable. Ensure all paddles are rotating freely and no binding or chattering is evident. **NOTE; If the paddles fail to complete an entire rotation, the canister drive shaft may not have been correctly installed in the drive plate. Remove canister and correct.**
- 12.) Plug in unit. **WARNING; This unit is equipped with an automatic timer and is scheduled to activate as soon as after the unit is plugged in. To avoid accidental breakage or personal injury, ensure all assembly procedures (steps 1-12) have been completed prior to plugging in.**

Your dispenser is now ready to be filled with colorant!

Please fill out and mail in your **Warranty Registration Card.**

ASSEMBLY INSTRUCTIONS

Ref #1

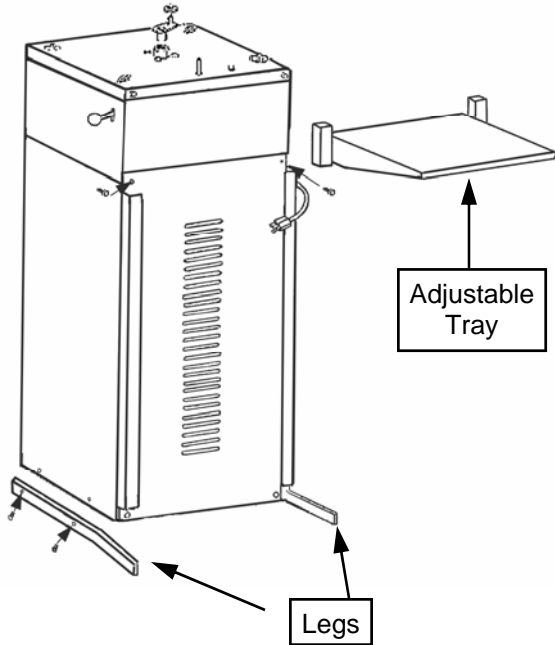

Steps 5 – 10

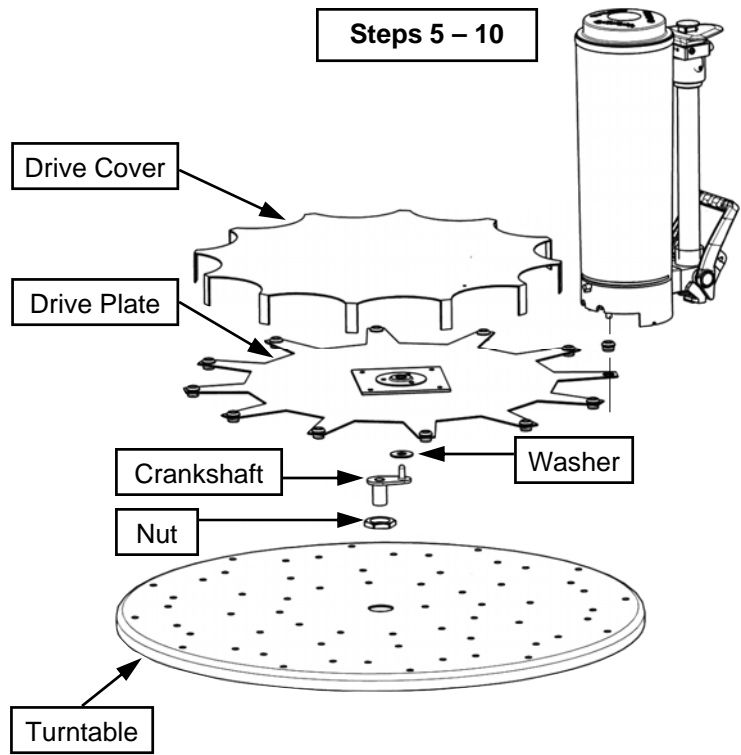

Steps 11 – 12

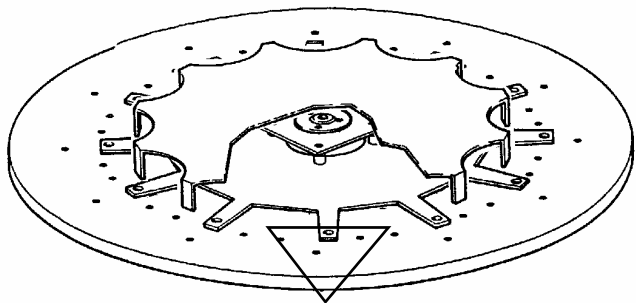

Steps 12 – 14

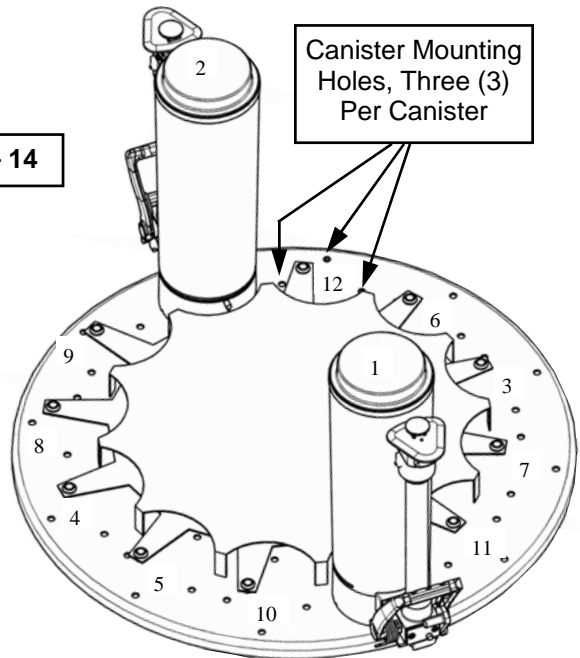

DISPENSER PREPARATION

PRIMING INSTRUCTIONS

With the unit assembled and canisters mounted, the following steps should be carried out to ensure that your machine is properly prepared for accurate and trouble-free dispensing. The canisters have a capacity of 2.5 quarts and it is recommended that only one (1) quart of colorant be used on the initial filling. Additional colorant can be added once proper operation is achieved.

- 1 Place each can of colorant into a mixer or shaker for approximately 5 minutes (or as specified by the colorant manufacturer) to mix any settled pigment.
- 2 Remove canister lids .
- 3 Pour the contents of each can of colorant into individual canisters.
NOTE: Apply the canister identification letters on each canister as the colorant is added. Applying the letter to the stainless steel cylinder tube, of the canister, provides the easiest reference.
- 4 Set the gauge, (Ref # 2) of each pump to the 2Y setting (by depressing the spring loaded button, (Ref # 3), and lifting the gauge by its handle).
- 5 Prime each cylinder by lifting the black plunger handle (Ref # 1) to its maximum travel. And pressing the plunger handle downward fully, **WITHOUT OPENING THE VALVE!** Repeat this Process 5-6 times This draws colorant from the canister into the cylinder and purges the air from the system.
- 6 Lift the plunger handle to its maximum travel. Place a clean can or paper cup under the dispense nozzle (Ref # 5). Open the discharge valve by pulling the valve lever (Ref # 4) downward its full travel. Push the plunger handle down fully to dispense colorant into the cup. Return the valve lever to the closed position. Repeat this procedure until the colorant emerges as an unbroken stream.
- 7 Once the cylinder is free of air, repeat steps 4 & 5 for all remaining canisters. Return all dispensed colorant to its respective canisters. Your machine is now ready for use!

DO NOT ADD COLORANT WHEN AGITATION IS TAKING PLACE

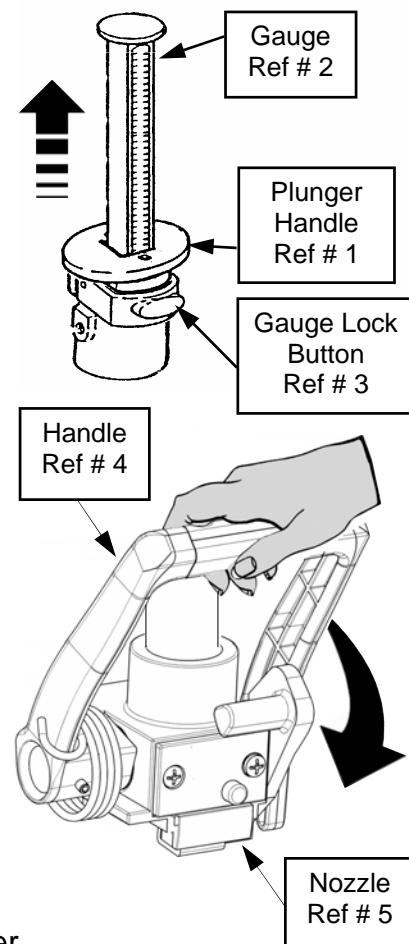

TINTING INSTRUCTIONS

- 1 Identify the color you wish to supply, either by name or code number.
- 2 Refer to your color formula reference book for the tint formula and note the tint base required.
- 3 Determine the formula required for the size of paint can being sold .
- 4 Ensure all gauges are set to zero before beginning.
- 5 Place the open can of paint under the dispensing nozzle. Depress brake lever and rotate the turntable until the appropriate canister is directly over the can of paint. If we find a formula which can not be measured in one dispense. Multiple dispenses will be required. It is **always** best to divide a formula into equal dispenses.

MICRO™ GAUGES (optional)

The Micro™-gauge is an innovative new way of dispensing increments smaller than 1 part. The Micro™ - Gauge allows you to dispense in 1/4 part increments. For formulas specifying dispenses of 1/2 or 1/4 part, rotate the micro-gauge knob until the appropriate number is aligned with the pointer. The Micro™-gauge settings can be used in combination with a regular setting, thereby making dispenses of 1Y-24-1/2 or 24-1/4 possible with a single discharge. **IMPORTANT: ALWAYS** return the Micro™ gauge knob to the "0" position after completing a paint order.

TINTING INSTRUCTIONS

CHARGING THE CYLINDER

NOTE: It is always best to divide the required formula into equal dispenses, even if it requires more dispenses than what might otherwise be required. Mistints are generally caused by operator error in setting the gauges. The fewer changes in the gauge settings, the lower the chances of errors.

- 1 With the gauge correctly set, slowly and gently lift the plunger handle until it reaches the gauge knob. Continue to hold for a few seconds to ensure that the cylinder has completely filled with colorant.

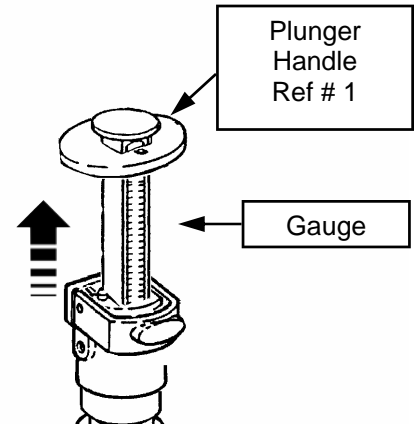

CAUTION: DO NOT open or operate the dispensing valve lever while charging the cylinder. If the valve is opened, even the slightest amount, air will be drawn into the cylinder chamber resulting in an inaccurate dispense. If the valve is accidentally opened during CHARGING, close valve and press the plunger handle down to return the colorant to the canister.

NOTE: If the colorant level is low in the canister, air can also be sucked into the cylinder. Press the plunger handle down to return the colorant to the canister. Add 1 or 2 quarts of new colorant. The cylinder must be re-primed. Refer to PRIMING INSTRUCTIONS on page 6.

DISPENSING FROM THE CYLINDER

- 1 With the plunger at the top and the cylinder full, pull the spring loaded valve handle (Ref # 2) forward its full travel.
- 2 Using your other hand, push the plunger handle (Ref # 1) down completely until it rests on the end cap.
- 3 Your full dispense is now complete.
- 4 Allow the lever to fully return to its normal position.
- 5 Repeat the charging and discharging process for the required strokes (total formula). Continue with the next required color.
- 6 When the entire paint order is complete, gently lower gauges to zero position. **DO NOT** push gauge release button and allow gauges to drop down. Lower manually to avoid damage.

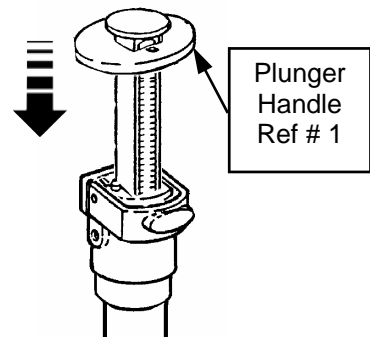

ACCU-PURGE™ VALVE

Activation of the Accu-Purge valve provides a small burst of air to clean the dispense nozzle of any remaining colorant and ensures clean dispensing ports and greater accuracy. The valve automatically works on each dispense.

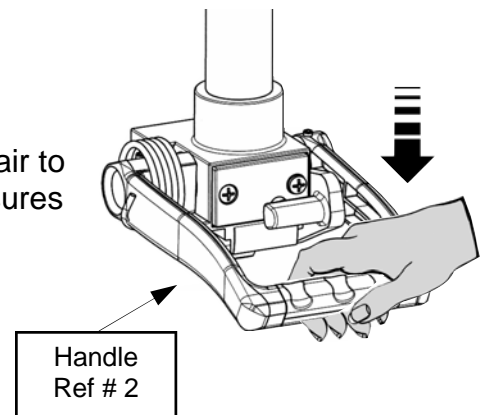

MAINTENANCE INSTRUCTIONS

DAILY MAINTENANCE

Keeping the nozzle seal pad (Ref # 2), clean and free of dried, dripping or collecting colorant is essential for trouble-free dispensing. It is recommended the nozzle seal arm / pad, be cleaned daily with a moist cloth., water or mineral spirits is satisfactory.

DO NOT use (lacquer thinner, MEK). Cleaning the colorant from the nozzle seal pad will lessen the possibility of mis-tints caused by the collection of colorant. If large accumulations of colorant on the seal arm/pad may be caused by a malfunction of the accu-purge valve.

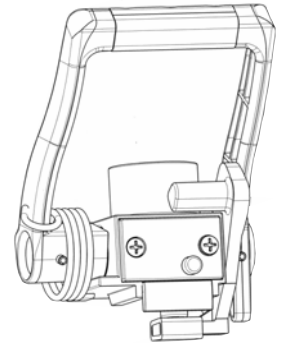

Ref # 20

PERIODIC MAINTENANCE

When the machine is not being used on a regular daily bases, the following procedures should be carried out;

- 1 Check the level of colorant and top up if required.
- 2 Open and close each valve lever five (5) times.
- 3 Set gauge to the maximum 2Y and stroke the plunger handle up and down three (3) times **without** opening the valve handle.
- 4 Check valve handle and nozzle seal arms / pads for possible damage, and clean thoroughly.
- 5 Dispense colorant into a paper cup and return to canister. Constant movement of colorant is required to prevent hardening of colorant in nozzle and valve assembly.
- 6 Colorants are heavy bodied fluids containing particle of pigment. During the plunger operation, a slight amount of colorant may stick to the cylinder wall, which after a period of time, may cause drag or stiffness in the operation of the plunger. A small amount of stiffness should cause no concern, If the stiffness of operation becomes difficult, Complete cleaning of the canister and pump will be required.

CARE FOR YOUR MACHINE

DO keep the machine clean and practice good housekeeping to promote accuracy in color dispensing.

DON'T use the pump as a handle while rotating the turntable. Grab the edge of the turntable to rotate the turn table

DO keep this copy of the HERO D23 Series Operating Manual, and reusable piston seal tool in a convenient place to assist in regular maintenance.

DON'T use metal or hard objects to clear blocked nozzles. Nozzles are easily removed for cleaning. Damage to valve barrel will result from using hard objects to clear nozzles.

DO keep nozzles clean to prevent drying colorant from blocking and making dispensing difficult.

DON'T drop gauges down into end cap.

DO lower gauges manually back into end cap to protect and protect them from damage.

TROUBLE SHOOTING

PROBLEM	CAUSE	SOLUTION
Intermittent spurts of colorant from the nozzle during dispensing.	Low colorant level, allowing air into the pump cylinder. Pump not properly primed	Fill canister and operate the plunger several times, without opening the valve. Dispense colorant into a paper cup to remove the air. Prime pump. See page 6
End cap twists or lifts during operation.	End cap loose on cylinder.	Push down end cap onto the cylinder, and Lightly tighten the two set screws (Ref # 8) in the end cap, until it can no longer be twisted by hand.
Canister is loose on turntable.		Tighten the mounting screws (Ref # 36).
Colorant appears on the piston shaft, and or gauge.	Worn or loose piston seals.	Refer to replacement of piston seals page 12.
Colorant does not dispense easily.	Nozzle is clogged or too small. Colorant is too heavy	Clear nozzle of obstructions. If problem continues, use a larger nozzle. (three extra nozzles are supplied with unit.) Thoroughly clean out canister and refill with new colorant.
Pump tube is loose on the canister.	Pump attaching bolts are loose.	Remove canister and tighten the bolts (See valve replacement page 14)
Colorant leaks around the outlet nozzle	Nozzle O-Ring is lost or damaged.	Inspect or replace. (see Page 11)
Colorant leaks around the Accu-purge button	Leaking O-Ring	Clean or replace O ring as required (see page 11)
Colorant leaks from side of dispenser handle.	Worn or damaged valve barrel O-Ring	Replace valve assembly (Part# BL 1555) See page 14.
Gauge line does not line up with plunger handle	Loose plunger handle	Tighten plunger handle. (see figure 3 on page 13)

PROBLEM SOLVING - DRIPPING COLORANT

Colorant drips around the equipment can be the result of many things and a series of steps must be taken to determine the solution to the problem. Before performing these tests, please review operating procedures in the owner's manual to ensure proper dispensing is being done. These steps must be performed in following order;

1. Check nozzle seal arm / pad for a collection of colorant. A small amount of colorant will collect on the nozzle seal pad. Cleaning of this area daily will ensure the collection does not reach the point were colorant drips from the nozzle seal pad. Clean this area daily. Fig. 1.
2. Check Accu-Purge operation. pull the valve handle down (see fig. 5), this will push accu-purge valve button. An air burst or colorant discharge should be felt / seen. If no action is felt or seen, remove the two screws holding accu-purge plate onto valve. Check for dried colorant in chamber. Clean and remove all residue. Ensure the passage is clear and O-ring is not damaged. Replace if required. See page 11. A non working accu-purge, will not remove the residual material from the nozzle, leading to greater colorant collection.
3. Set dispensing gauge to maximum setting. Raise plunger to the top. Let go of the plunger with the valve closed. The plunger handle should not move and remain stationary. Any movement in the plunger indicates the presents of air in the cylinder and the need to re-prime the pump. Air present in the cylinder will not allow the colorant to be drawn in properly and will result in inaccurate dispenses and leaking of colorant from the nozzle. Prime the cylinder, as per instructions on page 7.
4. Before continuing with steps 5 and 6, you must remove the nozzle See Fig. 4. These final two tests, CAN NOT be performed until steps 1, 2 & 3 have been done.
5. If there is a constant drip of colorant from the nozzle, air is entering the cylinder is a result of worn "**Piston Seals**". Replace per instructions on pages 12-13.
6. Push plunger shaft down to the end cap. With the valve closed, watch the nozzle for drips. If a constant drip of colorant comes from the nozzle, the valve barrel, O-rings or valve body are worn and replacement is required. Use valve replacement number BL-1555. Replace per instructions on page 14.

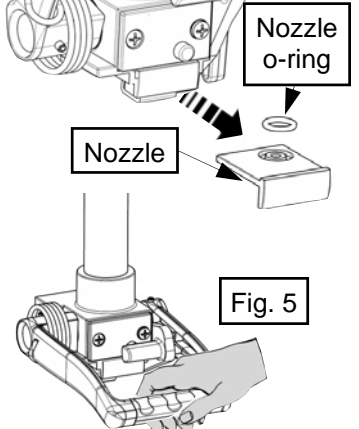
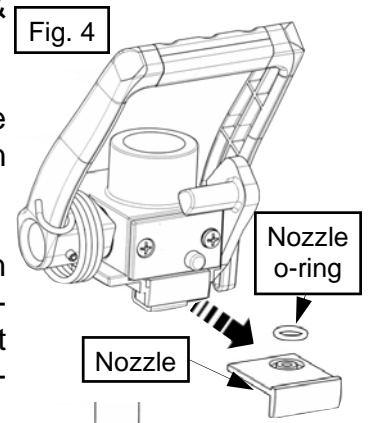
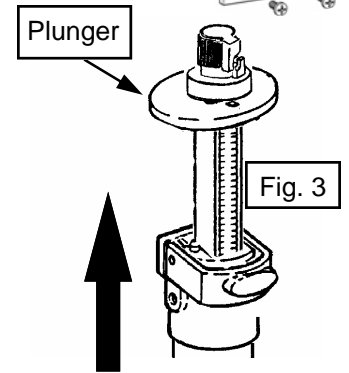
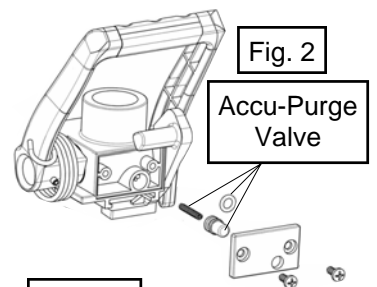
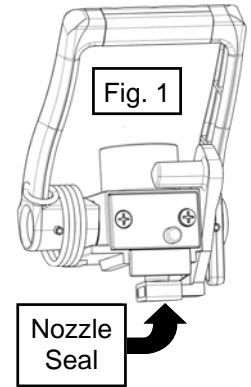

DRIPPING COLORANT – SERVICE & REPAIRS

Nozzle Seal Pad

After each dispense, a very small amount of colorant will remain in the nozzle. Between valve operations, this colorant will settle down onto the nozzle seal pad. When the valve is opened to dispense, the pad moves into a horizontal position. The accumulated colorant will drain down and around the pad. With the valve closed, the colorant is now on the under side of the pad. This constant repetitive action, will lead to a build up of colorant that will eventually drip to the ground. Daily cleaning of this area will prevent the colorant accumulation / drips. Wipe area with a moist cloth.

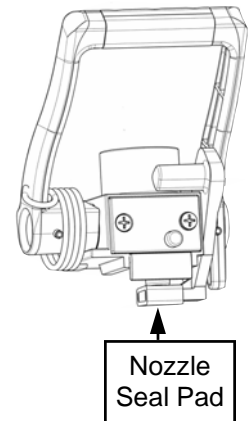

Nozzle Replacement and Cleaning

The valve nozzle (Ref # 22) is located at the bottom of the valve, and directs the colorant in a steady stream into the paint pail. A sealing o-ring (Ref # 21) is used to prevent leakage between the two surfaces. Colorant collecting around the area of the nozzle may be the result of a damaged or missing o-ring (Ref # 21).

To ensure trouble free operation, it is recommended that the nozzle outlets (Ref # 22) be cleaned only if there is a problem dispensing colorant. Frequent removal of nozzle may cause loss or damage to o-ring. To remove the nozzle, pull valve handle down, to move arm/pad away from nozzle. Continue to hold the valve open while pulling the valve forward towards yourself. Clean the nozzle in warm water, making sure that you don't lose the nozzle O-ring. (Ref # 22).

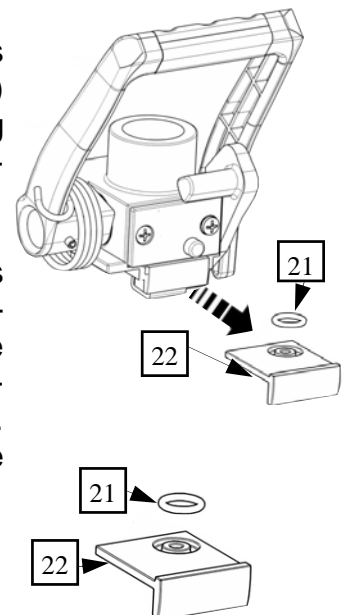

NEVER use hard sharp objects to clear the nozzle.

Accu - Purge™ Valve Repairs

To repair the Accu-Purge Valve.

- 1 Remove the two (2) screws (Ref # 28) securing valve plate (Ref #36)
- 2 Remove the Accu-Purge assembly (Ref # 24) and (Ref # 26).
- 3 Clean entire valve cavity, paying attention to the hole from which the button is removed.
- 4 Remove the O-ring and clean or replace.
- 5 Do not over tighten the screws when you reassemble.

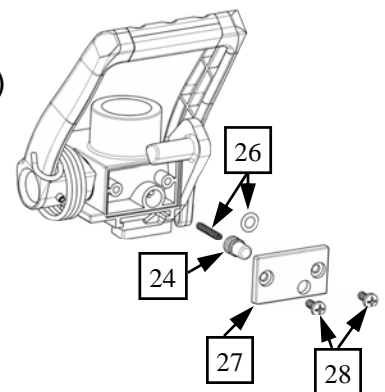



REPLACEMENT OF PISTON SEALS

To replace the piston seals you do not have to remove the canister from the turntable

Figure 1

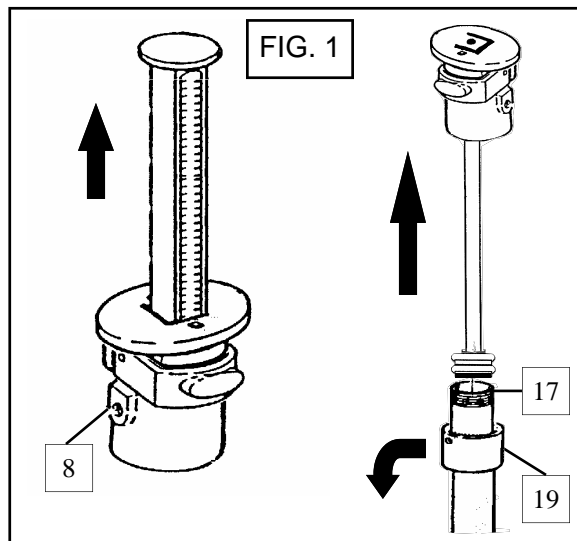
- 1 Remove gauge from canister.
- 2 Loosen the two set screws (Ref # 8) from the end cap assembly and allow sleeve (Ref # 16) to drop down the cylinder (Ref # 17)
- 3 Remove the entire end cap / plunger assembly from the cylinder, lifting vertically.
- 4 Clean colorant from piston assembly.



 Seal Installation Tool
 Part # BL-1510
 Supplied with each unit.
 Includes seal BL-1065

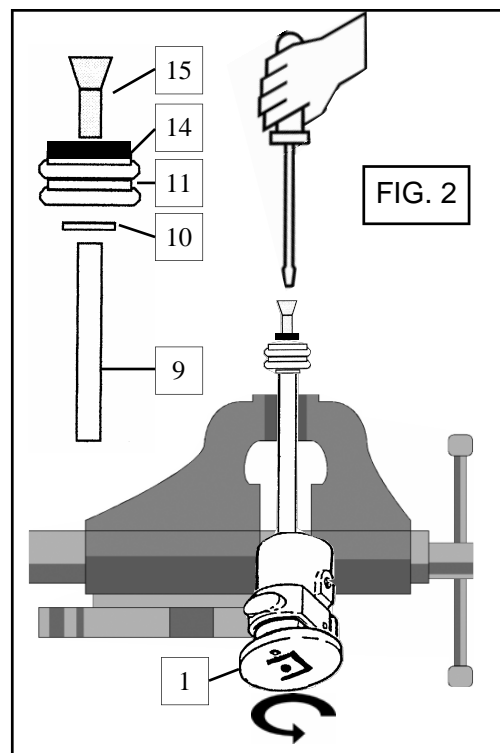

Figure 2.

- 1 Place plunger shaft in a “soft jaw” vise. **Do not** over tighten vise jaws.
- 2 Remove plunger handle (Ref #1) from shaft, turning counter-clockwise.
- 3 Slide end cap assembly off plunger shaft.
- 4 With a **Large** head, Phillips screwdriver, remove screw securing piston seals. Discard used seals, while retaining washer (Ref # 10), seal support (Ref # 14) and screw (Ref # 15).
NOTE: Screw is secured with Loc-Tite and may be difficult to remove. A large head screw driver is required to ensure screw head is not stripped or damaged during removal. If unable to remove screw, cut away old seals with knife and apply a small amount of heat to the screw. Heat will soften the Loc-Tite, allowing easier removal.
- 5 Remove **NEW** seal (One supplied free with each unit) from installation sleeve / tool.
- 6 Assemble seal lower support (Ref # 14), **NEW** piston seal (Ref # 11) , washer (Ref # 10), onto screw (Ref # 18). Apply 2 drops of Loc-Tite 271 to end of screw threads. Screw assembly into end of plunger shaft (Ref # 9).
NOTE: Tighten only until seal can no longer be rotated by hand. Do not over tighten. Over tightening will result in difficult or stiff operation of the plunger when re-fitted. See Special Instructions on page 15.
- 7 Remove plunger shaft from vise and slide installation sleeve / tool back over seals.

REPLACEMENT OF PISTON SEALS - CONTINUED

Figure 3.

- 1 Place the installation sleeve (*), containing seals (Ref # 11) and plunger shaft (Ref # 9), into a vertical position over the top of the cylinder. The tool will nestle / fit onto top of cylinder.
- 2 Gently press plunger shaft (Ref # 9) down, while rotating slightly, until the piston assembly is fully within the cylinder (Ref # 17).
- 3 With the piston assembly now contained within the cylinder, lift the installation sleeve (*) up and off the plunger shaft. Store sleeve for future use. *Replacement seals sold without tool.*
- 4 Raise seal to the top of the cylinder and ensure the seals have not been damaged during installation. Sealing edge / lip should not be curled, nicked or in any other way damaged.
- 5 Place end cap assembly (Ref # 3) over plunger shaft and re-attach plunger handle.
6. Attach plunger handle to the plunger shaft by turning clockwise until tight. We recommend using Loctite 401 on the threads. **DO NOT OVER TIGHTEN.** If the plunger handle is not in correct alignment with the end cap, when tight, release grip on plunger shaft and rotate to re-align. The end of the plunger shaft should be flush with or extended above the plunger handle.

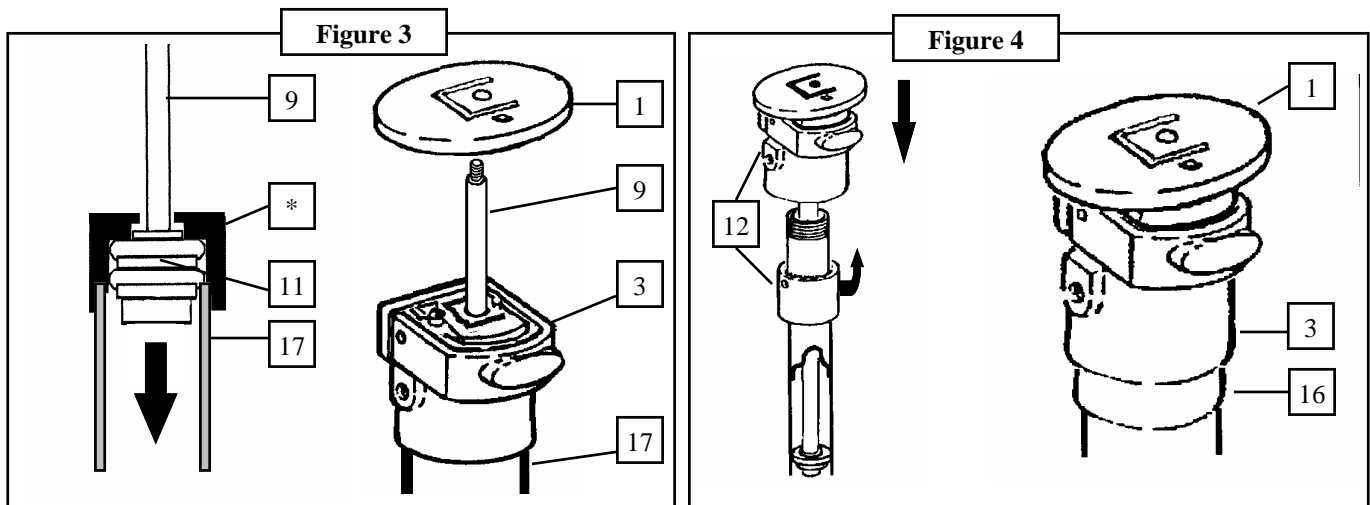

Figure 4.

- 1 Press the plunger shaft (Ref # 1) down until the seals have bottomed out in the valve body.
- 2 Slide the end cap sleeve (Ref # 16) up the cylinder and into the end cap assembly (Ref # 3).
NOTE: End cap sleeve, has two holes for the set screws (Ref # 8) to pass through. Be sure holes in sleeve and end cap are aligned to allow set screws to engage on the cylinder.
- 3 While keeping the plunger shaft pressed down, raise the end cap and sleeve until it engages the plunger handle. Confirm vertical alignment of end cap and valve, and secure end cap to cylinder with set screws (Ref # 8). **DO NOT OVER TIGHTEN.**
- 4 Refit gauge. Check calibration, see page 17 for details. Re-calibrate if not correct.
- 5 Prepare pump by following **PRIMING INSTRUCTIONS.**

SPECIAL INSTRUCTIONS

The piston seal will begin to expand as soon as it is removed from the cylinder. If the seal remains out of the cylinder for longer than 5 minutes the use of the installation sleeve may be required for re-installation.

BL-1555P - VALVE ASSEMBLY REPLACEMENT

All valve repairs require that the canister be removed from turntable. It is also recommended to drain the canister of colorant in order to minimize any mess associated with the repair.

- 1 Remove canister from turntable and empty contents (colorant) into clean container. Rinse canister of residual colorant.
- 2 With Allen key, remove the two screws (Ref # 46) holding the valve to the canister base. These screws are accessed from the bottom of canister.
- 3 Unthread cylinder / end cap assembly from valve assembly and set used valve assembly aside.

NOTE: DO NOT use any tools to loosen cylinder.

- 4 Thread cylinder / end cap assembly into new valve. Cylinder must be firmly, hand tight and the use of "SUPER" glue, on the cylinder threads is recommended.

NOTE: DO NOT use any tools to tighten. Review step 6 now.

- 5 Install o-ring (Ref # 25) to valve body and re-attach to canister (Reverse of step 1).
- 6 Re-installation of cylinder, may result in the end cap being out of alignment with the valve assembly. To align the end cap assembly with valve, loosen the set screws slightly (Ref # 12) and rotate endcap. Re-tighten set screws.
- 7 Install nozzle and o-ring (Ref # 34, 35), from old valve assembly, onto new valve.
- 8 Re-attach canister to turntable.
- 9 Add colorant and re-prime pump.

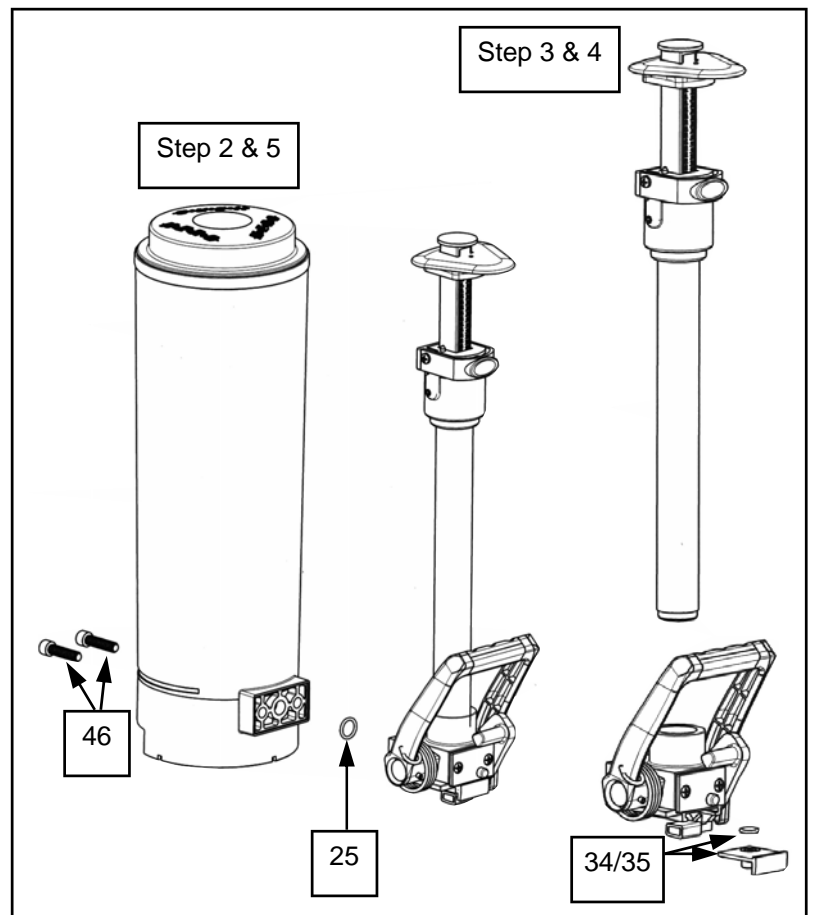
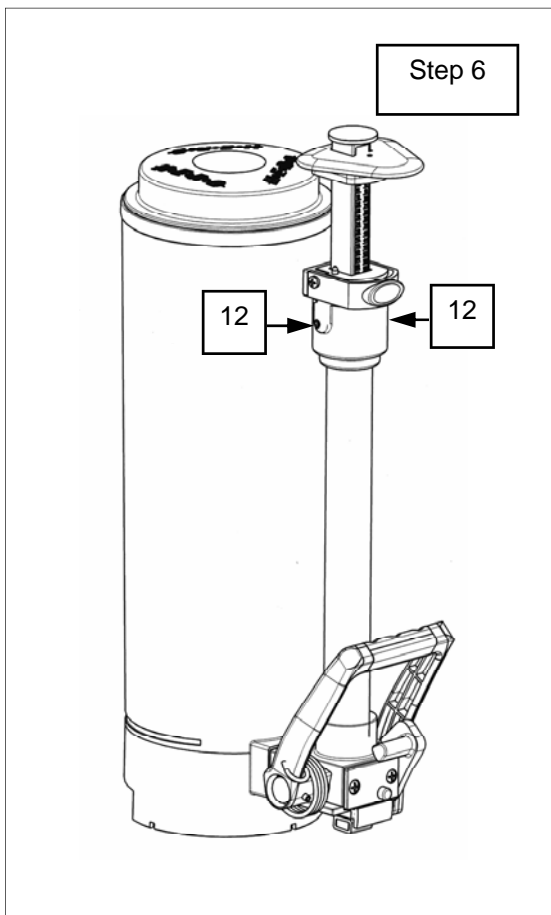

GAUGE RE-CALIBRATION/ Non-Micro Gauges

Gauges are precise measuring devices, and they are factory calibrated for its specific canister. Moving gauges from one canister to another will cause inaccurate dispenses, if the calibration is not re-set.

DO NOT MOVE A GAUGE FROM IT'S ORIGINAL CANISTER.

To install **NEW** Gauges for the first time the following instructions must be followed closely.

Tools Required:

- 5/64 Allan Key
- Feeler Gauge (See Size Below)

1. Remove standard gauge from the canister and note the number at the bottom of the gauge.
2. With an Allan key, turn the set screw (Ref # 2) , in the plunger handle (Ref # 1). Counter clockwise two full turns.
3. Insert gauge (See column **A** for gauge decal number and specifications) into canister.
4. Set gauge to calibration setting as specified in chart below (See column **B**).
5. Raise plunger handle by turning set screw (Ref # 2) until it contacts the gauge stop and can not be raised any further.
6. Insert the feeler gauge (See column **C** in chart below for correct size) into the gap between the plunger handle and the end cap. Ensure the feeler gauge is directly below the set screw.
7. Turn set screw (Ref # 2) clockwise until contact with the feeler gauge is made. **Do Not over tighten**. The feeler gauge should be able to be pulled out from the canister with only a very slight drag.

(The thickness of feeler gauge is the distance required of the plunger to travel to make a 1/2 or 1 shot dispense. **Example**– A 1/48 US gauge (Decal # BL-5006) must travel .038 of an inch to dispense 1/96 or a half shot of colorant).

CALIBRATION CHART FOR NON-MICRO GAUGES		
A	B	C
Standard Gauge	Increment	Feeler Gauge
Decal Part Number	Setting	Clearance
BL-5001 - 1/32 US	1/2 Shot	.054
BL-5006 - 1/48 US	1/2 Shot	.038
BL-5007 - 1/96 US	1/2 Shot	.038
BL-5011 - 1/64 US	1 Shot	.054
BL-5021 - 1/48 USM	1/2 Shot	.038

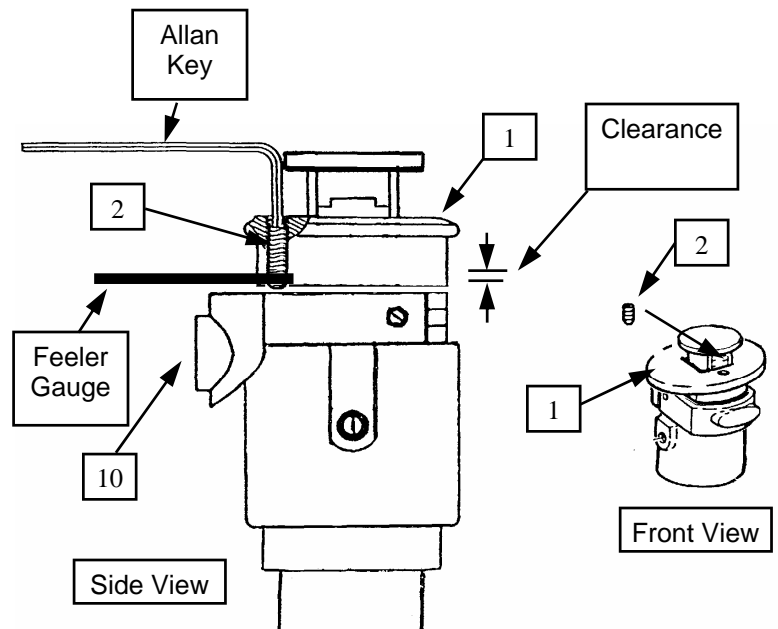

CALIBRATION INSTRUCTIONS - MICRO GAUGES™

Micro gauges are precise measuring devices and are designed for use with one specific canister, the one it is originally installed in and calibrated to. Moving gauges from one canister to another will cause inaccurate dispenses. When installing new Micro-Gauges for the first time the following instructions must be followed closely. Each gauge must be calibrated to one specific canister, and should remain in that specific canister.

NOTE: Before attempting calibration of the gauges, make sure that the plunger handles (ref 1, Fig 1) are tight on the plunger shaft.

1. Insert new gauge into canister.
2. Set gauge to first locking hole or position (zero "0").
3. Make sure the micro knob is set to zero
4. Apply **Loc-Tite** to setscrew (ref# 49, fig 2) and insert into micro knob (Set screw found in parts bag). Tighten set screw (ref# 49) so that the set screw makes contact. **DO NOT** over tighten.
5. Check the gauge locking operation (push item 10 ,fig 1) to ensure the gauge locks in on the zero setting. Over tightening will prevent the locking pin from engaging properly.
6. Rotate Micro-Knob and return it to zero (0) try to raise plunger handle (ref# 1, fig 1). No movement should be felt in the plunger handle with the Micro-Knob set at zero (0). If there is movement in the plunger tighten the set screw (ref 49, fig 2) until there is no movement and the gauge locks in on the zero setting.
7. Place cap on Micro-Knob (cap found in parts bag).

MICRO GAUGE™ RECALIBRATION

If gauges have been moved from one canister to another the gauges will have to be recalibrated. To recalibrate the gauges you would follow the same procedures as above, except that instead of adjusting the set screw in the center of the gauge, as above. You adjust the calibration by turning the screw in the plunger handle. (see fig 1).

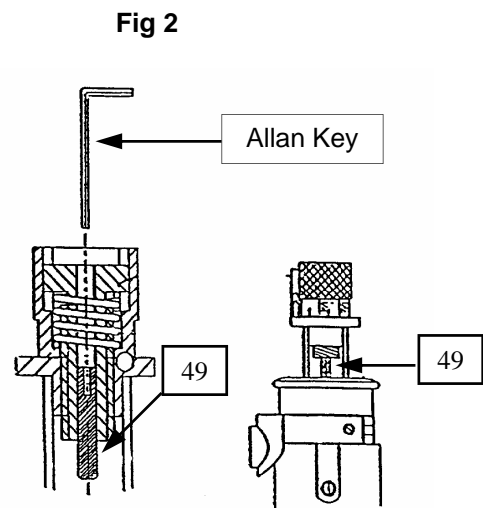
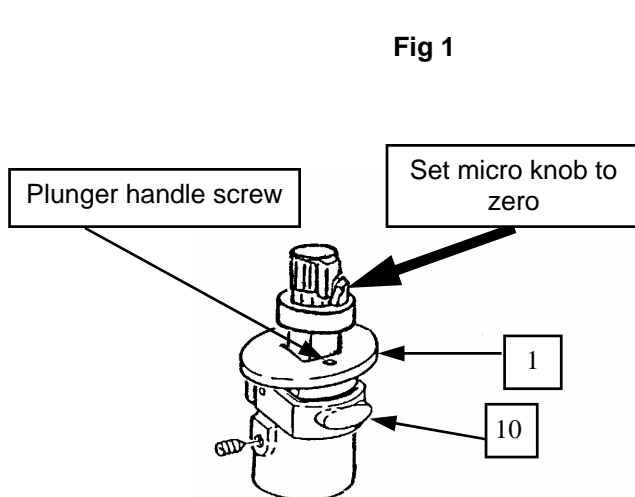

AUTOMATIC TIMER & WIRING SCHEMATIC

Illustrations and special instructions are for 110V, 60HZ models.
Units with 220V, 50 HZ power sources, are supplied with an on/off switch . Local standards apply for electrical installation.

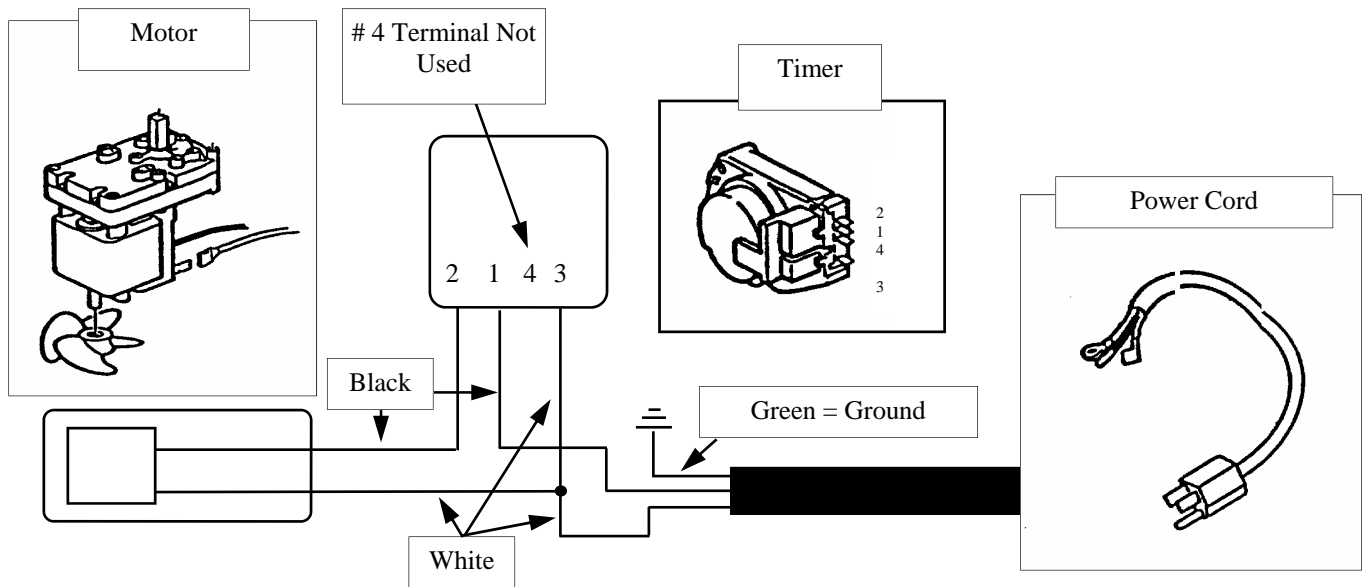

IMPORTANT GROUNDING INSTRUCTIONS

This product should be grounded. In the event of an electrical short circuit, grounding reduces the risk of electrical shock by providing an escape for the electrical current. This product is equipped with a cord having a grounding wire with an appropriate grounding plug. The plug must be plugged into an outlet that is properly installed and grounded in accordance with all local codes and ordinances.

DANGER: Improper installation of the grounding plug can result in a risk of electrical shock. If repair or replacement of the cord is necessary, do not connect the grounding wire to either flat blade terminal. The wire with insulation having an outer surface that is green with or without yellow stripes is the grounding wire. Check with a qualified electrician or serviceman if the grounding instructions are not completely understood, or if in doubt as to whether the product is properly grounded. Do not modify the plug provided; if it will not fit the outlet, have a proper outlet installed by a qualified electrician. This product is for use on a nominal 120-volt circuit and has a grounding plug that looks like the plug illustrated in sketch A in figure 65.1 of UL Standard 1450. Make sure that the product is connected to an outlet having the same configuration as the plug. No adapter should be used with this product.

Only use a 3-wire extension cord that has a 3-blade grounding plug, and a 3-slot receptacle that will accept the plug on the product. Make sure that your extension cord is in good condition. When using an extension cord, be sure to use one heavy enough to carry the current your product will draw. An undersized cord will cause a drop in line voltage resulting in loss of power and overheating. Refer to the following table:

Length	25	50	100	150	200	250	300	400	500
Gauge	18	16	14	12	10	10	8	8	6

AUTOMATIC TIMER

Every HERO D23 Series Colorant Dispenser is equipped with an automatic timer. The timer operates for every 10 min every 7 hours at 110V 60Hz or 4 hours at 220V 50Hz. The timer requires no adjustment or attention on the part of the operator. When shipped the timer has been set to initiate agitation as soon as it is plugged in.

The timer is located on the cabinet / base, next to the power cord. A decal is located next to the timer, indicating the location of the start position. In order to rotate the timer adjustment knob you will require a flat end screw driver as the knob is inset into the machine for protection. By rotating the adjustment knob, the timer can be advanced to the start time. While rotating the knob, a faint clicking sound will be heard. Rotate the dial through the “off” cycle until agitation begins. The “on” cycle is very short so rotation of the adjustment knob must be done very slowly. You should hear a loud click during rotation, this will start the agitation. Once the ten (10) minute agitation cycle is complete the timer will then activate agitation every seven (7) or (4) hours from this point.

HERO

2000 COLORANT DISPENSERS
2000 DISTRIBUICES DE COLORANTS

MODEL #

SERIAL #

VOLTS A.C. AMP Hz

 TOLL FREE
1-800-494-4376
U.S. & Canada

CAUTION
ARCING PARTS
Keep the unit at least 20 feet
Away from explosive vapors

**READ OPERATING
INSTRUCTIONS**
High pressure device.
Read instruction manual
before operating and observe
all warnings.

ATTENTION
ÉTINCELLES ÉLECTRIQUES
Né Pas placer l'unité à moins de
20 pieds des vapeurs explosives

**LIRE DE MODE
D'EMPLOI**
Matériel à haute pression. Lire
les instruction du fabricant avant
de mettre en marche, et observer
toutes les consignes de sécurité.

VANCOUVER, B.C. CANADA
MADE IN CANADA - FRABRIQUE DU CANADA PAR



**TO TURN TIMER ON
SLOWLY ROTATE
CLOCKWISE UNTIL
FIRST LOUD CLICK**

**ADJUST TIMER
with flat blade
screwdriver**

DAILY ROUTINE CARE OF THE DISPENSER
It is recommended that the following daily routine be adopted to ensure trouble free operation of the dispenser.

1. Check the level of the colorant and top up if required.
2. Set all gauges to maximum dispense. Raise and lower each plunger without opening valve. Repeat the procedure 10 times slowly.
3. With a damp cloth, wipe down stand, canisters and pumps, paying particular attention to pump nozzles to prevent accumulation of excess colorant which may dry out and cause erratic discharge or blockage.

Located on right side
of cainet / base
(when facing unit)

CANISTER SCHEMATIC MODEL D23PR/PRM

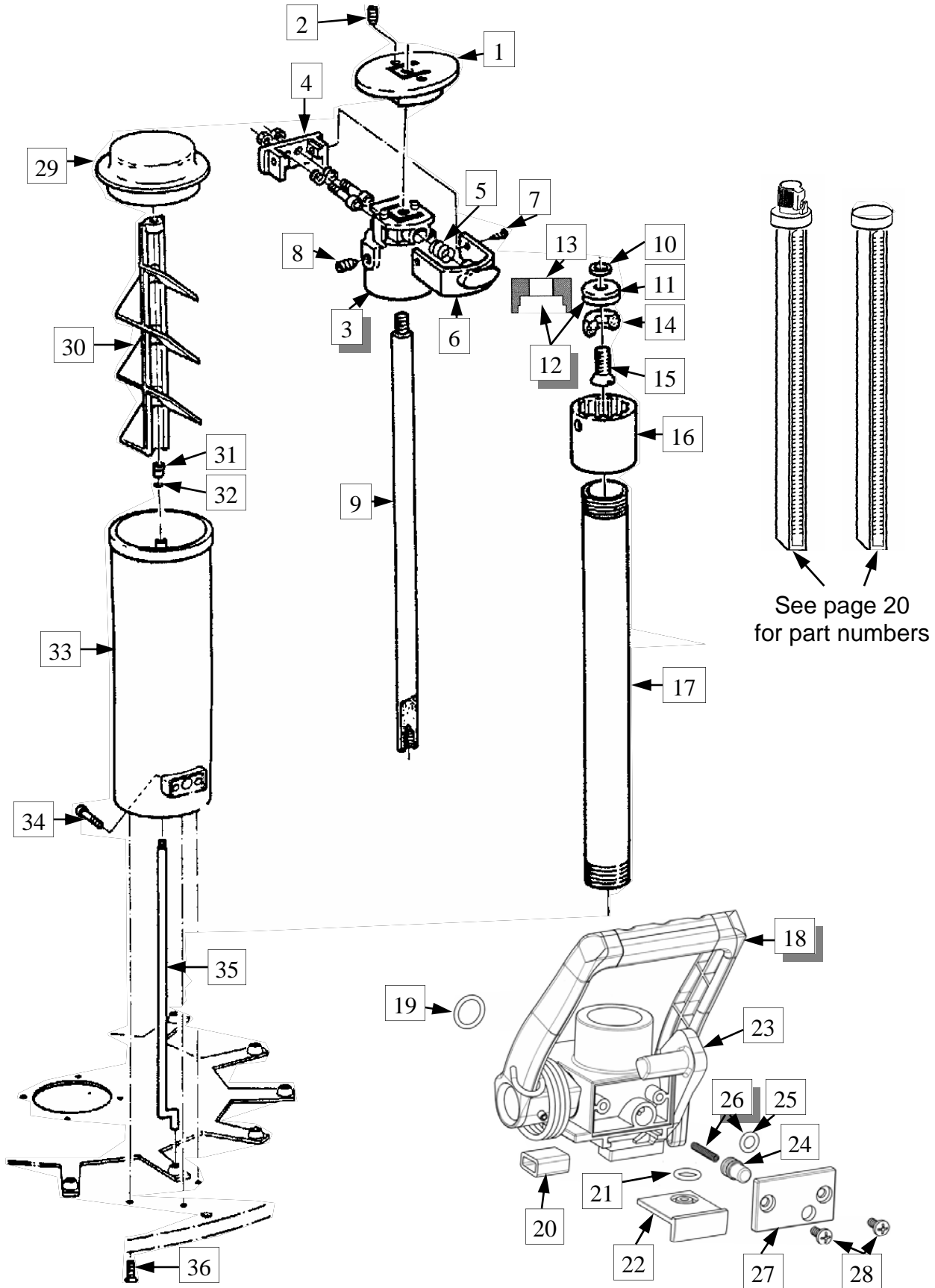

CANISTER SCHEMATIC AND PARTS LIST

MODEL D23PR/PRM

Please identify or order parts by the appropriate part number and not by reference number. The parts description indicates the quantity of each part per canister, if more than one is required

REF #	PART #	DESCRIPTION
	BL-1700-04	Canister / Pump assembly, less gauge,
1	BL-1000	Plunger handle
2	HW2062	Set screw
3	BL-1501	End cap assembly, c/w # 4-8, & 16
4	BL-1505	Pin bar assembly
5	BL-1032	Spring, gauge pin return
6	BL-1030	Gauge lock bar
7	HW30051P	Screw, 2 per end cap
8	HW2075	Set screw, 2 per end cap
9	BL-1005	Plunger shaft, 2 oz.
10	HW5032	Washer, SS
11	BL-1065	Seal, 2 oz.
12	BL-1510	Seal, 2 oz., with installation tool Ref # 13
13	BL-1067	Installation tool, 2 oz.
14	BL-1066	Plunger seal support
15	HW30623	Screw
16	BL-1025	End sleeve
17	BL-1520	Cylinder, 2 oz., SS
18	BL-1555P	Valve assembly complete, includes Ref # 18, less nozzle
19	BL-1136	O-ring, valve body
20	BL-1176	Wiper pad
21	BL-1192	O-ring, nozzle
22	BL-1185	Nozzle, .094, - S = Small, optional
	BL-1186	Nozzle, .125, - M = Medium, standard on D23P
	BL-1187	Nozzle, .188, - L = Large, optional
	BL-1188	Nozzle, .220, - X = X-Large, optional
23	BL-1173	Auto Accu-Purge wiper arm
24	BL-1405	Piston, Accu-Purge valve
25	BL-1402	O-Ring, Accu-Purge valve
26	BL-1620	Accu-Purge valve assembly, includes spring & o-ring
27	BL-1132	Valve plate
28	HW30051P	Screw, 2 per valve
29	BL-1085	Lid
30	BL-1530	Paddle, 2.5 Qt., assembly
31	BL-1095	Bushing
32	BL-1105	O-ring, paddle bushing
33	BL-1540	Canister shell, polymer, 2.5 Qt., includes Ref # 31, 32
34	HW1017	Cap screw, 2 per canister
35	BL-1115	Paddle drive shaft, 2.5 Qt.
36	HW30629P	Screw, 3 per canister

DISPENSING GAUGES

STANDARD GAUGES

GAUGE Ref # 48	DECAL Ref # 49	DESCRIPTION	MODEL CODE
BL-5500	BL-5001	1/32 US	01
BL-5505	BL-5006	1/48 US	02
BL-5506	BL-5007	1/96 US	23
BL-5510	BL-5011	1/64 US	03
BL-5520	BL-5021	1/48 USM	05

MICRO GAUGES TM

GAUGE Ref # 48	DECAL Ref # 49	DESCRIPTION	MODEL CODE
BL-5600	BL-5101	1/32 US	01
BL-5605	BL-5106	1/48 US	02
BL-5607	BL-5107	1/96 US	23
BL-5610	BL-5111	1/64 US	03
BL-5615	BL-5116	1/32 USM	04
BL-5620	BL-5121	1/48 USM	05

WHAT ARE GAUGES ?

The gauge is simply an indexing device. Precision made to ensure precise indexing of colorant. Colorant manufacturer's create an entire spectrum of available color formulations based on their product. To create this spectrum of colors, The formula requires that small portions of various colorants be added to the base paint. The amount of colorant added, is measured in "fluid ounces. The ounce measurement is further broken down into fractional dispenses. The popular increments are 32, 48 and 64 parts per ounce. The size of the paint container into which the colorant is being added is very important. Formulas created with the US gallon as a basic size, must be altered when dispensing into Imperial Gallons (US IMP) or Metric Pails (USM).

One (1) ounce of colorant is commonly referred to as "1Y" (Y = 1 ounce).

WHAT GAUGES DO I HAVE ?

Each unit model number has a code incorporated into the part number which designates the gauges being used. Each gauge decal also has a part number listed at the bottom of it. Refer to gauge decal number or the model code per chart above.

Unit model # ; D24SR12F0204E = 1/48 US gauge (BL-5505), Decal # BL-5006, Model code 02.

TURNTABLE SCHEMATIC AND PARTS LIST

Please identify or order parts by the appropriate part number and not by reference number. The parts description indicates the quantity of each part per canister, if more than one is required

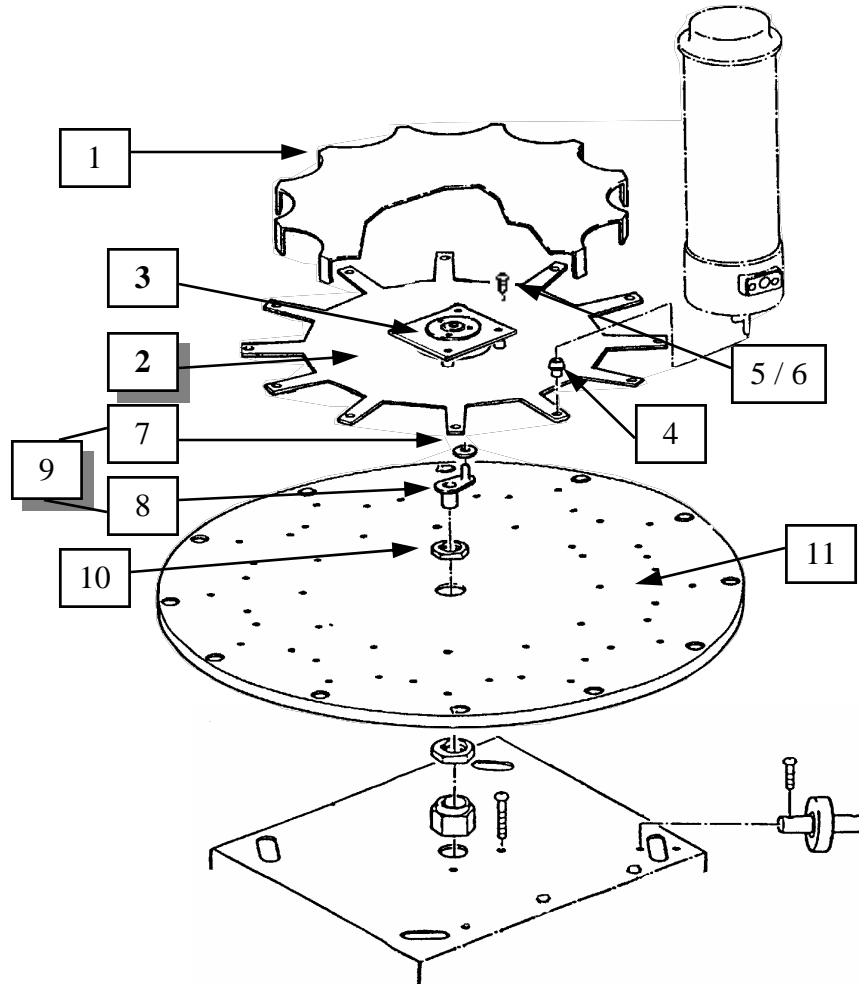

REF #	PART #	DESCRIPTION
1	BL-2050W	Drive Cover, 12 Position, White
	BL-2060W	Drive Cover, 16 Position, White
2	BL-2520	Drive Plate Assembly, 12 Position
	BL-2540	Drive Plate Assembly, 16 Position
3	BL-2515	Center Plate Assembly
4	BL-2047	Bushing, Drive Plate,
5	HW3041P	Screw
6	HW5010P	Washer, Shake Proof
7	BL-2020	Nylon Crankshaft Washer
8	BL-2010A	Crankshaft
9	BL-2510	Crankshaft & Washer Assembly
10	BL-2075	Turntable Nut
11	BL-3000W	Turntable, 12 Position,
	BL-3010W	Turntable, 16 Position,

FLOORSTAND PARTS LIST

Please identify or order parts by the appropriate part number and not by reference number. The parts description indicates the quantity of each part per assembly, if more than one is required.

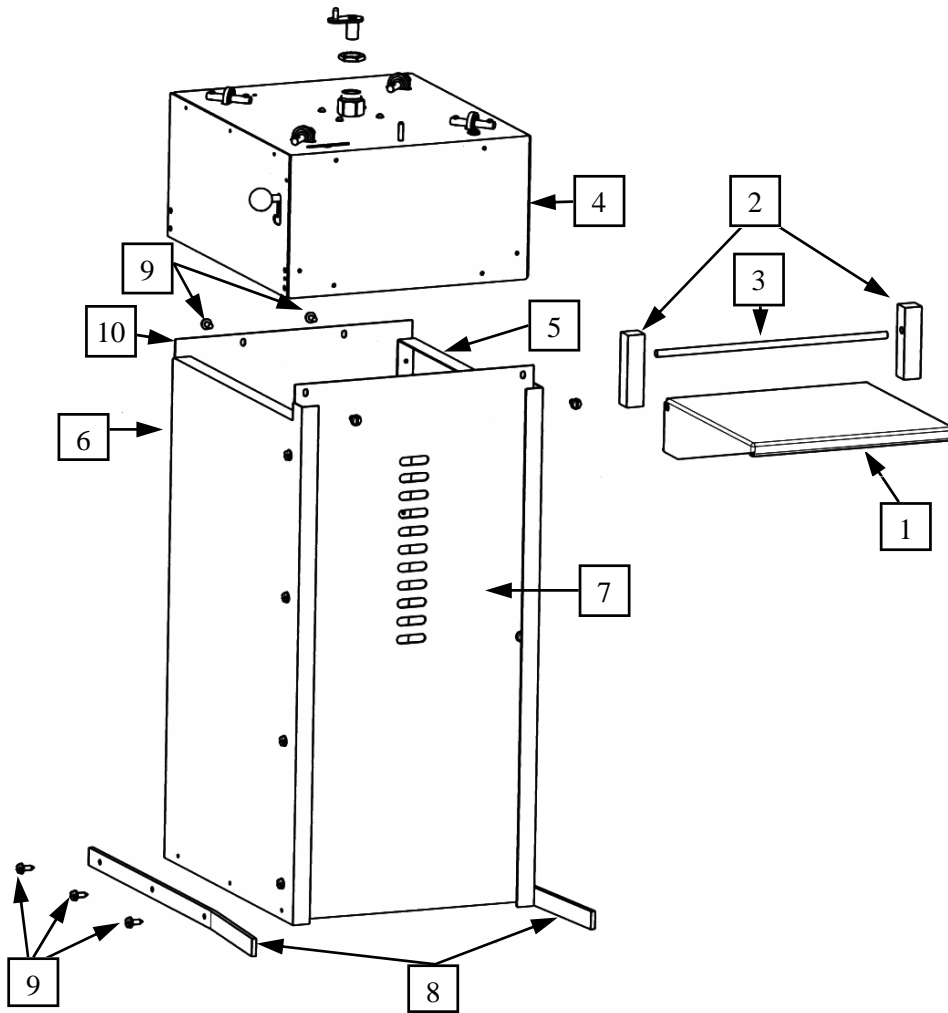

REF #	PART #	DESCRIPTION	QTY
	BL-3760	Floor stand complete, with electrics	1
1	BL-3355	Shelf, 12 Position	1
	BL-3359	Shelf, 16 Position	1
2	BL-3358	Glide	2
3	BL-3357	Support rod	1
4	BL-3501	Counter top assembly (see page 25 for parts)	1
5	BL-3351	Side panel, right	1
6	BL-3352	Side panel, left	1
7	BL-3354	Front panel	1
8	BL-3300	Support leg, 2 required	2
9	HW-3066P	Screw	22
10	BL-3353	Rear panel	1

COUNTER TOP STAND PARTS LIST

Please identify or order parts by the appropriate part number and not by reference number. The parts description indicates the quantity of each part per assembly, if more than one is required.

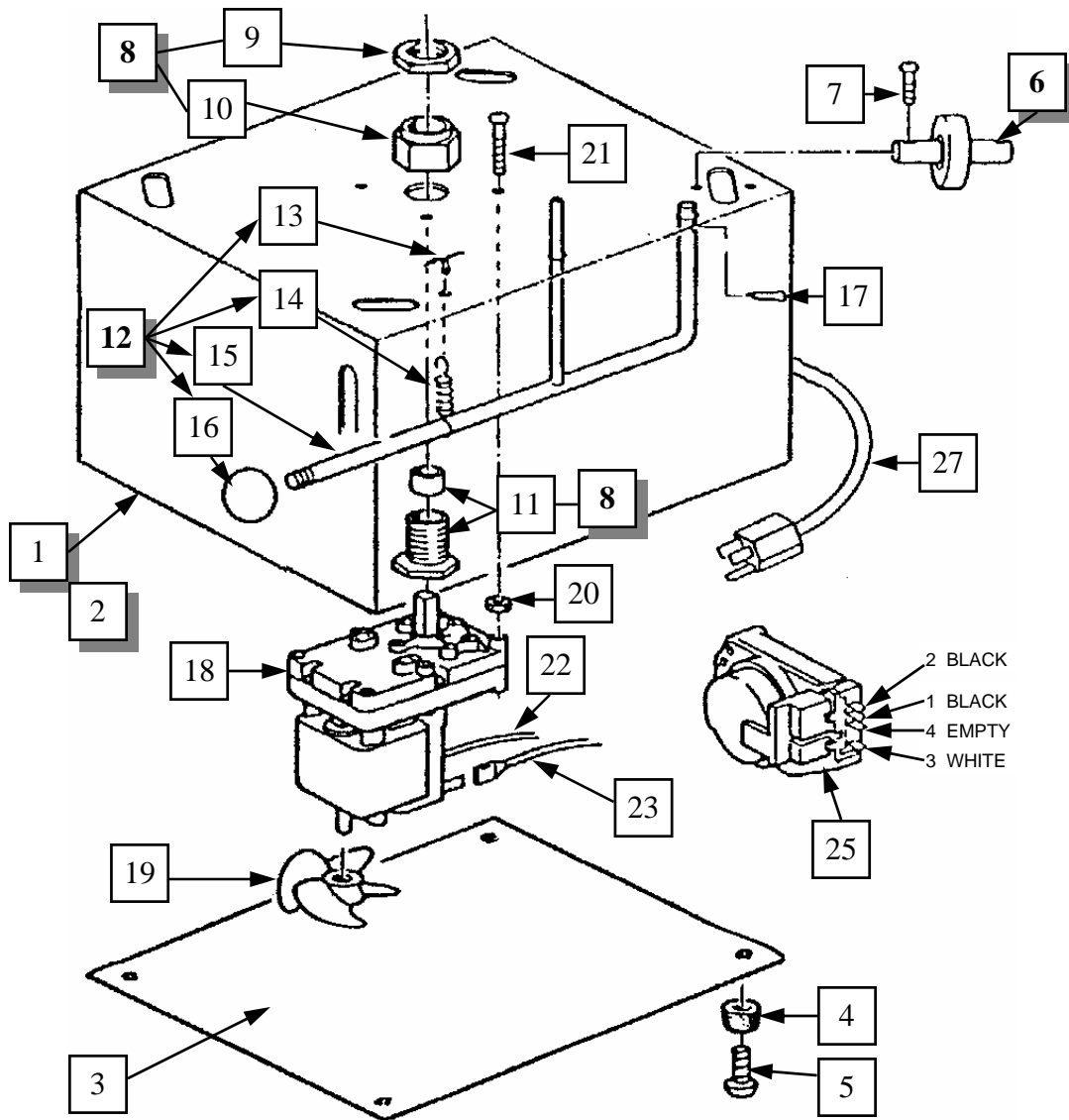

COUNTER TOP STAND PARTS LIST

Please identify or order parts by the appropriate part number and not by reference number. The parts description indicates the quantity of each part per assembly, if more than one is required.

REF #	PART #	DESCRIPTION	QTY
1	BL-3501	Counter Top Stand, c/w electrics,	1
2	BL-3500	Counter Top Stand, metal only less electrics	1
3	BL-3210	Counter base, bottom plate	1
4	BL-3215	Counter base, bumper	4
5	HW3032P	Screw	4
6	BL-3505	Roller wheel assembly	4
7	HW3032P	Screw	8
8	BL-3511	Swivel assembly, Includes Ref # 9 - 11	1
9	BL-2075	Nut, turntable	1
10	BL-2070	Swivel nut	1
11	BL-3512	Swivel body and bearing,	1
12	BL-3600	Brake assembly, Includes Ref #13 - 17	1
13	67/17	Cotter pin	1
14	BL-3110	Spring	1
15	BL-3100	Brake lever	1
16	BL-3105	Knob, brake handle	1
17	HW6086	Cotter pin	2
18	BL-2004	Motor, AC, Includes Ref # 22, 110V, 60 HZ	1
export	BL-2005	Motor, AC, Includes Ref # 22, 220V, 50HZ	1
19	BL-2003	Fan	1
20	BL-2008	Spacer, motor mounting	4
21	HW3050P	Screw	4
22	BL-3605	Wire, c/w connectors, white	2
23	BL-3615	Wire, c/w connectors, black, timer to motor,	1
24	BL-3610	Wire, c/w connectors, black, Not Shown	1
25	BL-2000	Timer, automatic, 10 min. On / 7 Hrs. Off, 110V, 60 HZ	1
export	BL-2001	Timer, automatic, 10 min. On / 7 Hrs. Off, 220V, 50HZ	1
26	85-15	Connector, wire joint, insulated, white, Not Shown	1
27	BL-3620	Power Cord, 6 feet	1
28	85-16	Bushing, strain relief, Not Shown	1

HERO D23 SERIES COLORANT DISPENSER WARRANTY & CLAIM PROCEDURES

HERO Products Group is proud to offer an industry leading " Two Year Warranty " on all of its *Manual Series Colorant Dispensers*.

HERO Products Group warrants all it's Manual Series Colorant Dispensers to be free of defects in materials and workmanship, to the original user, for a period of Two (2) Years. The warranty entitles the owner to parts replacement at no charge. The parts warranty is valid for any necessary replacement, whether caused by material, workmanship defect or simple wear.

Electric motors, timers and pneumatic motors warranted for twelve (12) months only.

The warranty is applicable to the original owner only and is non-transferable. The equipment must be used, operated and maintained in accordance with all instructions, precautions and warnings contained in the owner's manual. For the purpose of this warranty, damage caused by accident, abuse, improper cleaning or lack thereof, or improper operation, is not covered. Cleaning and general maintenance is the responsibility of the owner / operator and is not covered by the warranty.

HERO's liability is limited to the replacement of parts found to be defective or worn and does not include; damage or other expenses of any kind incurred in connection with the purchase and use of the dispenser.

All parts required for warranty service are invoiced to the client, with credit provided upon submission of a valid warranty claim. A valid claim lists model number, serial number, date of installation, lists all parts used and provides provisions for parts installation labor charges.

Major parts replacement may require the return of defective parts. If uncertain, call for further instructions. All returns must be authorized and no return will be accepted without a Return Goods Authorization (RGA) number.



SERIAL NUMBER: _____

DATE INSTALLED: _____

PURCHASED FROM _____