

ROAD FORCE ELITE (RFE) (For Domestic and Export)

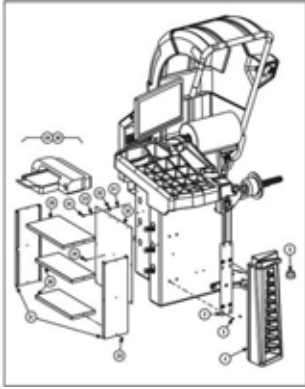

SHEET 3

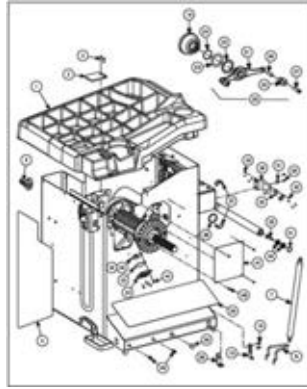

SHEET 4

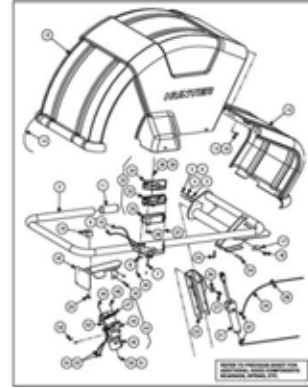

SHEET 5

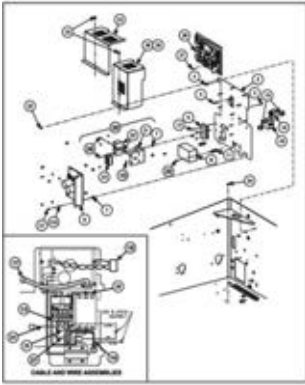

SHEET 6

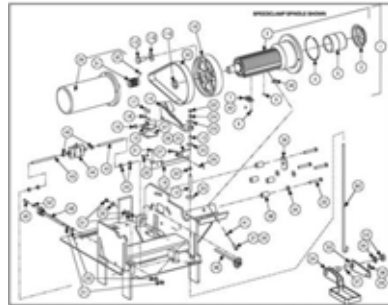

SHEET 7

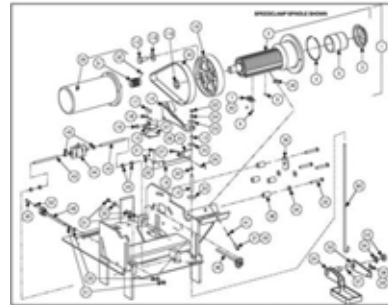

SHEET 8

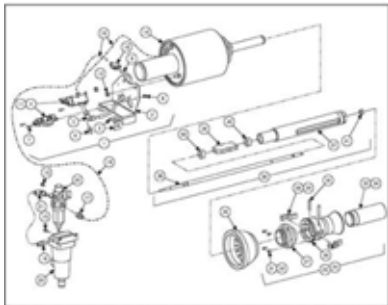

SHEET 9

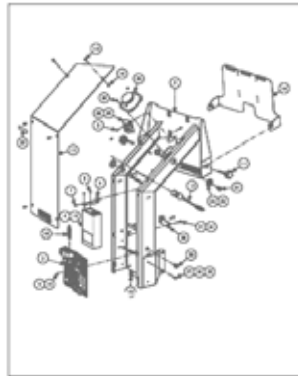

SHEET 10

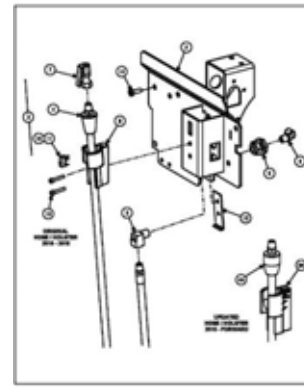

SHEET 11

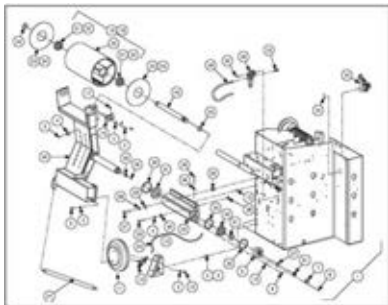

SHEET 12

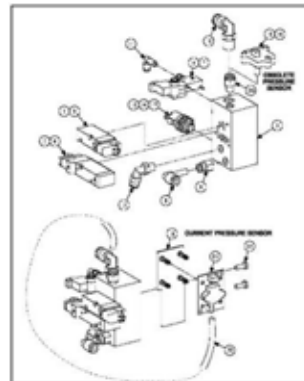

SHEET 13

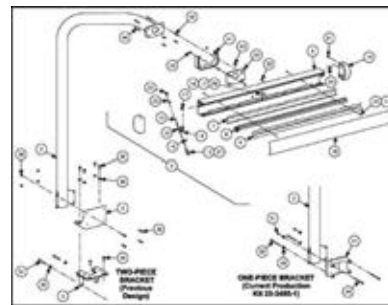

SHEET 14

ROAD FORCE ELITE (RFE) (For Domestic and Export)

REFER TO NEXT SHEET FOR PARTS DESCRIPTION LISTING

PARTS DESCRIPTION LISTING

Sheet No.	Description <i>(PDF navigation - click on image or description to go to sheet)</i>
3	COLLET STORAGE AND PRINTER OPTION
4	TUB EXTERIOR COMPONENTS AND WING NUT
5	HOOD AND SMARTSCAN
6	ELECTRIC PANEL
7	VIBRATION STRUCTURE
8	VIBRATION STRUCTURE
9	SPEEDCLAMP FEATURE
10	TOUCH SCREEN SUPPORT
11	INFLATION SUPPORT ASSEMBLY, 11-1633-1
12	LOAD ROLLER
13	LOAD ROLLER MANIFOLD
14	TOP DEAD CENTER LASER SYSTEM

ADDITIONAL PARTS DRAWING

	Form Number	Description	BALANCERS
1	Form 12-28	BALANCER WHEEL LIFT (KIT 20-3101-1)	RFE1X, RFE3X

BASE ASSEMBLIES

	Part Number	Description	BALANCERS
1	72-604-1	BASE, RFT BALANCE, GEN5	RFE00, RFE01. RFE02, RFE03
2	72-604-1	BASE, RFT BALANCE, GEN5	RFE10, RFE11. RFE12, RFE13
3	72-630-1	BASE, RFT BALANCER SC	RFE20, RFE21. RFE22, RFE23
4	72-630-1	BASE, RFT BALANCER SC	RFE30, RFE31. RFE32, RFE33

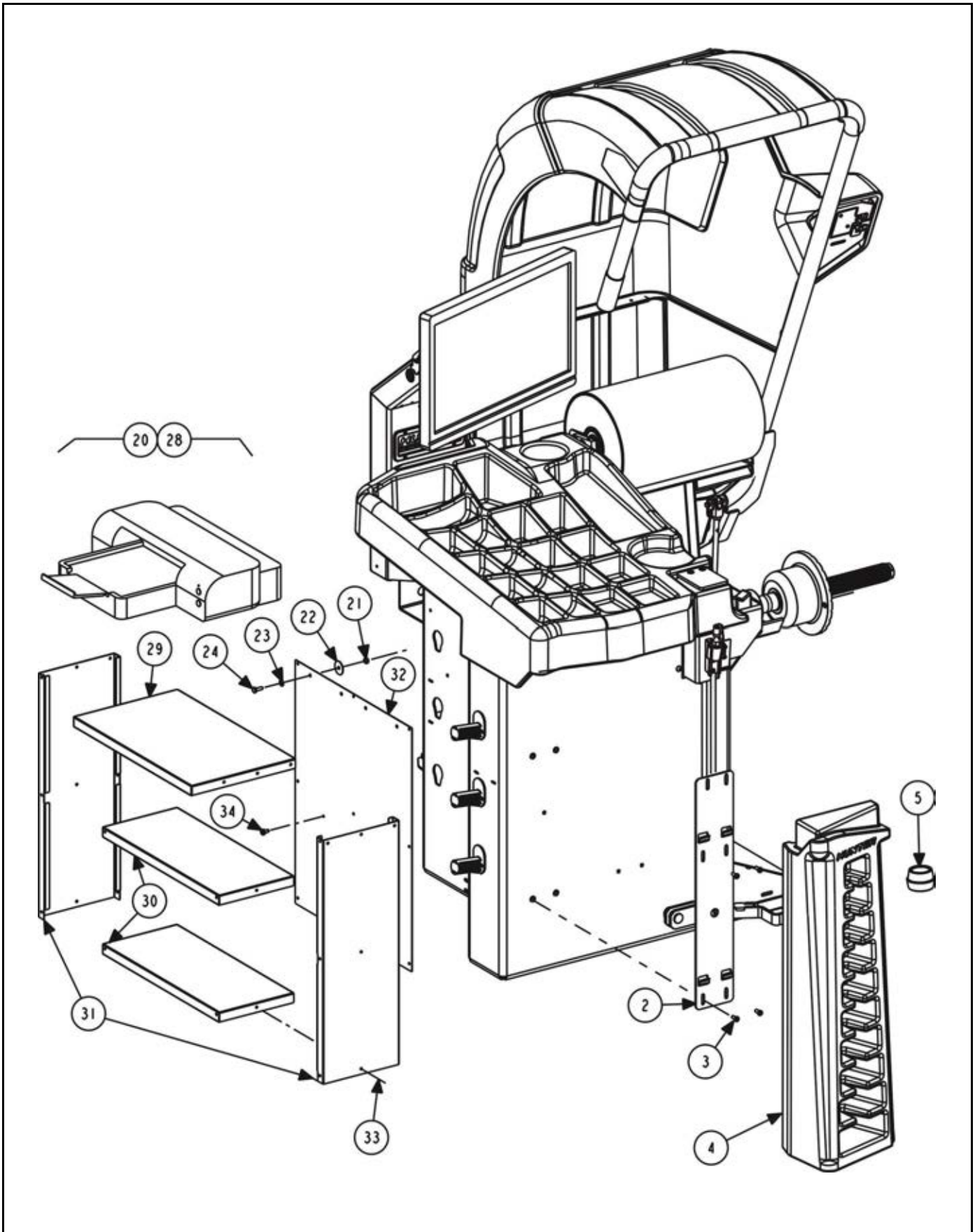

COLLET STORAGE AND PRINTER OPTION

REFER TO NEXT SHEET FOR PARTS DESCRIPTION LISTING

PARTS DESCRIPTION LISTING

Index No.	Part Number	Description	Qty.
1	base	BASE, RFT BALANCER	
2	14-1470-005	BRACKET, CONE SUPPORT	1
3	75-758-2	SOCKET BUTTON HEAD CAP SCREW 1/4-20 X .63 INCH	4
and	76-414-2	NUT-HEX INSERT 1/4-20	4
4	56-70-2	CARRIER, CONE, BALANCER FRONT LEFT-HAND	1
5	20-2711-1	KIT, GEN 4 BALANCER CENTERING (Standard on RFE) (Consisting Of:)	1
6	20-2683-1	KIT, P-3/4TON DUAL TAPER COLLET	1
7	192-213-1	CONE, 2.10-2.31, 2.26-2.47 (GREY / BLACK STRIPED)	1
8	192-214-1	CONE, 2.42-2.63, 2.58-2.79 (YELLOW / BLACK STRIPED)	1
9	192-215-1	CONE, 2.74-2.95, 2.89-3.11 (SMALL GREEN / BLACK STRIPED)	1
10	192-216-1	CONE, 3.05-3.27, 3.21-3.42 (SMALL BLUE / BLACK STRIPED)	1
11	192-217-1	CONE, 3.37-3.58, 3.53-3.74 (RED / BLACK STRIPED)	1
12	192-218-1	CONE, 3.69-3.90, 3.85-4.06 (ORANGE / BLACK STRIPED)	1
13	192-219-1	CONE, 4.01-4.22, 4.17-4.38 (LIGHT GREY / BLACK STRIPED)	1
14	192-220-1	CONE, 4.32-4.54, 4.48-4.70 (PURPLE / BLACK STRIPED)	1
15	192-221-1	CONE, 4.64-4.85, 4.80-5.01 (BIG GREEN / BLACK STRIPED)	1
16	192-222-1	CONE, 4.96-5.17, 5.12-5.33 (BIG BLUE / BLACK STRIPED)	1
17a	46-653-2	SPACER, 1.50 INCH WHEEL OFFSET MTG (Not Illustrated)	1
17b	175-392-1	ADAPTOR, BALANCER CUP WITH RETAINER 6 INCH	1
17c	106-157-2	SLEEVE, CLAMPING 6 INCH CUP	1
18	20-2680-1	KIT, BALANCER SOFTWARE (Not Illustrated)	1
19	20-1650-1	KIT, RIM TAGS (Not Illustrated)	1
20	20-2714-1	SHELF PRINTER, GEN 4 BALANCER (Optional) (Consisting Of:)	1
21	76-368-2	NUT, LOCK 1/4-20 NYLON INSERT	2
22	77-144-2	WASHER, FENDER 1/4 INCH	2
23	77-67-2	WASHER, FLAT 1/4 INCH	2
24	75-29-2	HEX HEAD CAP SCREW 1/4-20X.75 INCH	2
25	38-954-2	CABLE, USB 2.0 A/B 2 METER (Not Illustrated)	1
26	28-90-2	FASTENER, VELCRO 2 INCH HOOK SIDE (Not Illustrated)	1
27	28-89-2	FASTENER, VELCRO 2 INCH LOOP SIDE (Not Illustrated)	1
28	215-179-1	SHELF ASSEMBLY, PRINTER (Consisting Of:)	1
29	215-180-005	SHELF, PRINTER TOP	1
30	215-134-005	SHELF, PRINTER SUPPORT BALANCER	2
31	71-236-005	SIDE, PRINTER SHELF BALANCER	2
32	171-283-005	PANEL, REAR PRINTER SHELF	1
33	48-56-2	RIVET, BLIND 3/16 X 1/4 INCH	23
34	75-458-2	SCREW, SELF-TAPPING 10-16 X 1 INCH	2
35	38-1155-2	CABLE, IEC C13/C14 3 FEET (Not Illustrated)	1
36	38-911-2	CABLE, MONITOR POWER TO PC POWER (Not Illustrated)	1
37	128-1628-3	DECAL, RS BALANCER DOMESTIC (Not Illustrated)	1
OR	128-1678-3	DECAL-RFE BAL, EXPORT (Not Illustrated) (Not for USA or Canada)	1
38	128-603-2	DECAL, AIR PRESSURE LIMITS (Not Illustrated)	1
39	24-164-2	NAMEPLATE GSP9700 PATENT (Not Illustrated)	1
40	128-1419-3	DECAL, WHEEL BALANCER SAFETY (Not Illustrated)	1

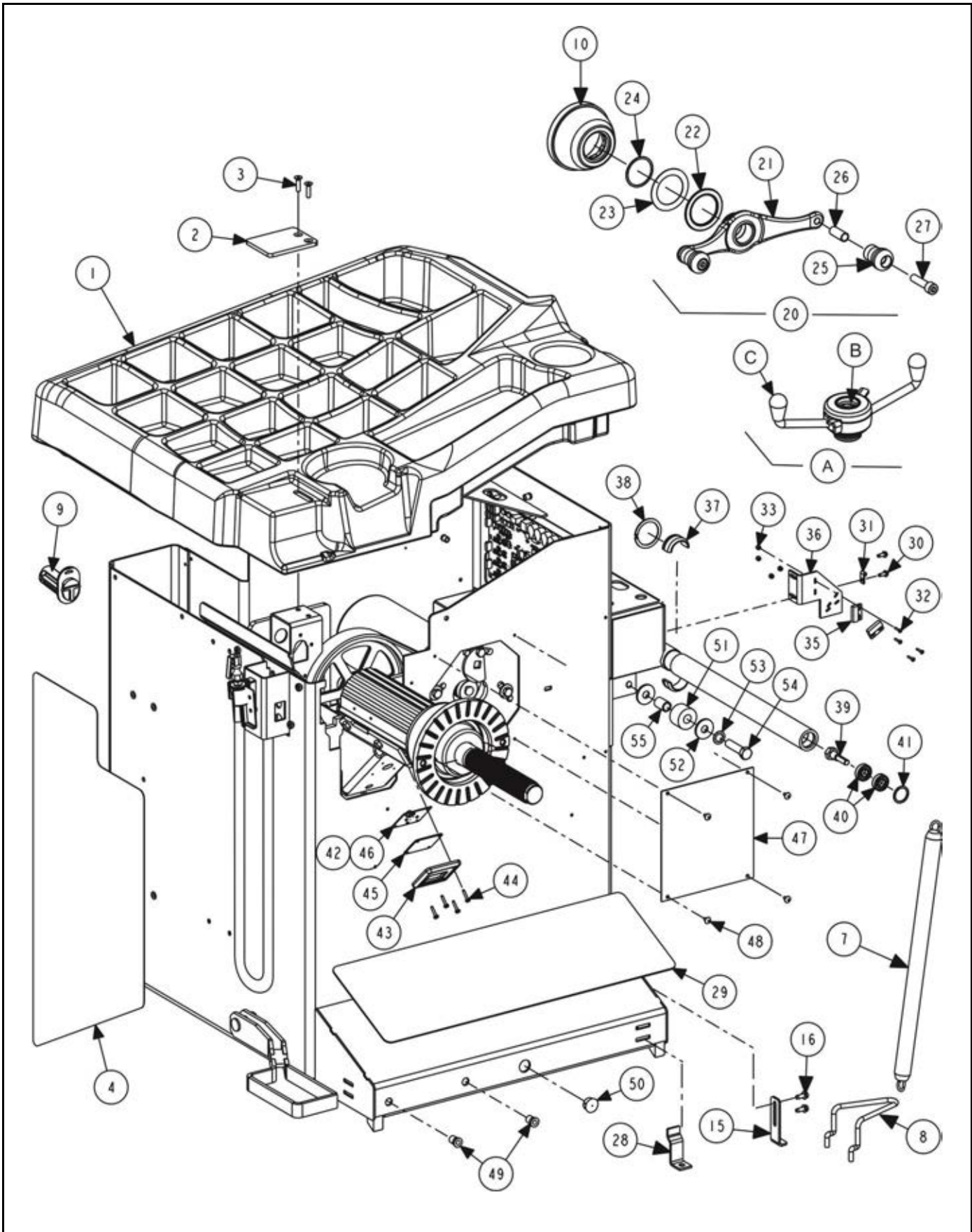

TUB EXTERIOR COMPONENTS AND WING NUT

REFER TO NEXT SHEET FOR PARTS DESCRIPTION LISTING

PARTS DESCRIPTION LISTING

Index No.	Part Number	Description	Qty.
1	69-1559-2	COVER, WEIGHT TRAY TRIMMED	1
2	51-2168-2	PLATE, WEIGHT ANVIL 9200	1
3	75-226-2	FLAT HEAD SOCKET CAP SCREW 1/4-20 X 1.00 INCH	2
4	128-1639-2	DECAL, ROAD FORCE ELITE	1
5	20-2145-1	KIT, GSP BALANCER ACCESSORIES (Consists Of:)	1
6	65-72-2	WEIGHT, CALIBRATION (Not Illustrated)	1
7	98-303-2	SPRING, HOOD	1
8	216-43-2	HOOK, LOWER SPRING MOUNT, GSP BALANCER	1
9	233-44-2	POST, CONE HOOK PLASTIC	9
10	175-353-1	ADAPTOR, BALANCER CUP WITH RETAINER (Includes)	1
11	41-138-2	RETAINER-ROUND WIRE, 2.00 DIAMETER	1
12	46-320-2	SPACER, SPINDLE SHAFT (Not Illustrated)	1
13	106-82-2	SLEEVE, CLAMPING CUP (Not Illustrated)	1
14	223-68-1	RING, BALANCER PRESSURE WITH RETAINER (Not Illustrated)	1
15	14-1346-005	BRACKET, BALANCER LEG LONG	1
16	75-317-2	SCREW, THREAD ROLLING 1/4-20 X 5/8 INCH	2
17	221-589-2	TOOL, WEIGHT HAMMER / PLIERS (Not Illustrated)	1
18	221-780-2	TOOL, NYLON HAMMER HEAD (Not Illustrated)	1
19	221-659-2	TOOL, ADHESIVE WEIGHT REMOVER (Not Illustrated)	1
20	76-433-3 (or 76-597-3)	NUT, FORGED WINGNUT W/ HANDLES (597 is long handle version) (C. Of:)	1
21	76-426-2 (or 76-596-2)	NUT, FORGED WINGNUT (596 is long handle version)	1
22	130-250-3*	BEARING WITH WASHER, NEEDLE 55 mm*	1
23	130-250-3*	BEARING WITH WASHER, NEEDLE 55 mm *	1
24	112-87-2	SNAP RING, SMALLEY WS-200	1
25	142-148-2	HANDLE, WINGNUT	2
26	106-154-2	SLEEVE, WINGNUT HANDLE	2
27	74-206-2	SOCKET HEAD CAP SCREW 1/2-13 X 2 INCH, (FULL-THREAD)	2
A	76-574-2	NUT-QUICKNUT ERGONOMIC (Optional)	1
B	20-3417-2	KIT, REPAIR FOR QUICKNUT ERGO (Clamping Mechanism)	1
C	20-3519-2	KIT, KNOB REPAIR FOR QUICKNUT (Plastic Handles)	1
28	216-111-2	HOOK, FLOOR / SHIPPING HOLD DOWN	3
29	64-158-2	PAD, FOOT	1
30	75-413-2	SCREW, SELF-TAPPING 10-32 X .50 INCH	2
31	12-145-2	CLAMP, CABLE 1/4 INCH DIAMETER	1
32	75-584-2	TRUSS HEAD MACHINE SCREW 4-40 X 5/8 INCH	4
33	76-366-2	NUT, LOCK 4-40 NYLON INSERT	6
34	75-401-2	TRUSS HEAD SHEET METAL SCREW 10 X 1/2 INCH	8
35	18-497-1	SWITCH, REED SWITCH ASSEMBLY	2
36	14-1116	BRACKET, 9722 HOOD SWITCH	1
37	130-244-2	BEARING, WHEEL COVER	2
38	112-80-2	SNAP RING, EXTERNAL, 1.75 DIAMETER	1
39	74-590-2	SHOULDER SCREW, SPECIAL 1/2 INCH DIAMETER	1
40	130-172-2	BEARING, SEALED BALL	2
41	112-124-2	SNAP RING, INTERNAL 1.125 INCH	1
42	45-1403-1	PCA, WHEEL LIGHT XPE	1
43	69-1375-2	COVER, SPINDLE LED	1
44	75-801-2	SCREW, SELF-TAPPING 6-32 X 3/4 INCH	4
45	44-38-2	WINDOW, WHEEL ILLUMINATION	1
46	37-625-1	WIRE ASSEMBLY, SPINDLE LIGHT	1
47	69-1028-PPP	COVER, SPINDLE DRIVE MOTOR	1
48	75-401-2	TRUSS HEAD SHEET METAL SCREW 10 X 1/2 INCH	4
49	76-413-2	NUT, HEX INSERT 5/16-18	2
50	43-111-2	PLUG, 7/8 INCH DIAMETER HOLE	1
51	228-25-2**	STOP, 1.50 INCH OUTER DIAMETER RUBBER TUBE	1
52	77-214-2**	WASHER, FLAT 1/2 SPECIAL	2
53	77-22-2**	WASHER, LOCK 1/2 INTERNAL TOOTH	1
54	74-345-2**	HEX HEAD CAP SCREW 1/2-13 X 2.00 INCH GRADE 5	1
55	113-174-2**	BUSHING, STEEL .69 OUTER DIAMETER X .522 INCH INNER DIAMETER	1

* Wingnut service item 130-250-3 contains needle thrust bearing and two thrust washers.

** Hood stop added in mid-2017. Hood stop cannot be retrofitted to earlier design due to lack of weldment mount.

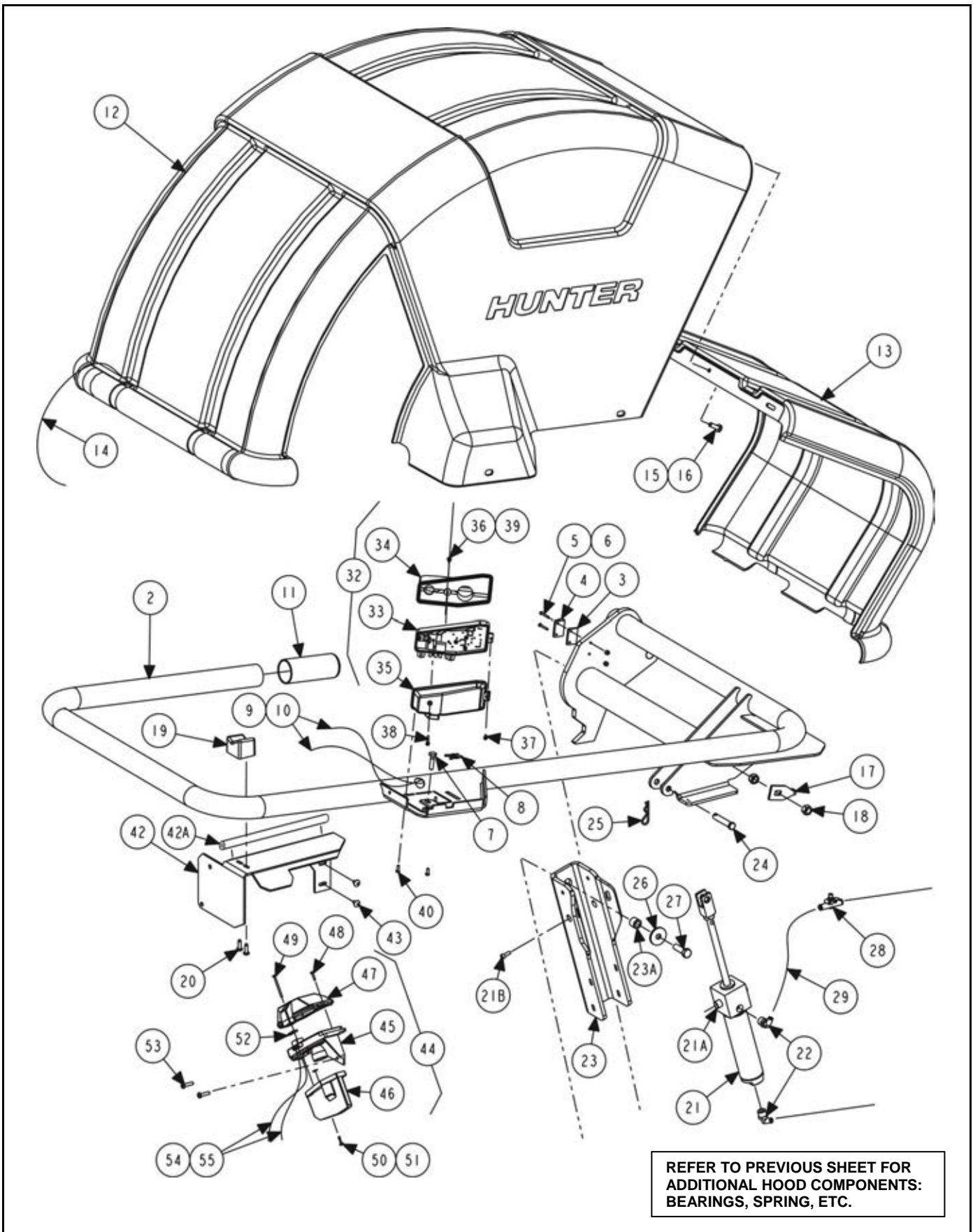

HOOD AND SMARTSCAN

REFER TO NEXT SHEET FOR PARTS DESCRIPTION LISTING

PARTS DESCRIPTION LISTING

Index No.	Part Number	Description	Qty.
1	69-1567-1	COVER, GEN5 HOOD ASSEMBLY (Consisting Of:)	1
2	16-1115-1-005***	TUBE ASSEMBLY, WHEEL COVER, RFT	1
3	46-445	SPACER, MAGNET	1
4	60-24-2	MAGNET, REED SWITCH ACTUATOR	1
5	75-199-2	ROUND HEAD MACHINE SCREW 4-40 X 7/8 INCH	2
6	76-366-2	NUT, LOCK 4-40 NYLON INSERT	2
7	75-865-2	SCREW, SPECIAL 1/4-20	1
8	112-173-2	RETAINING RING, SPLIT 3/16 INCH DIAMETER	1
9	38-1290-2	CABLE, USB 2.0 A/B 3 METER	1
10	38-1284-3	CABLE, ENCODER / OUTER CAMERA	1
11	53-221-2	CAP, VINYL 1.5 INCH ID X 4 INCH	1
12	69-1562-2	COVER, WHEEL, GEN5 BALANCER	1
13	69-1368-2	COVER, RR WHEEL WITH LOAD ROLLER	1
14	94-35-2	TIE-WIRE, 15 INCH X 1/2 INCH	7
15	75-128-2	PAN HEAD MACHINE SCREW 1/4-20 X 3/4 INCH	3
16	76-367-2	NUT, FLANGE 1/4-20	3
17	12-244-005	CLAMP, WHEEL COVER	1
18	76-26-2	NUT, HEX 3/8-16	2
19	228-94-2	STOP, HOOD FRONT	1
20	75-870-2	SCREW, SELF-TAPPING 10-14 X 5/8 INCH	2
21	140-116-2*	CYLINDER, AIR, 1 1/2 INCH DIAMETER	1
22	145-492-2	FITTING, 1/4 INCH NPT, 5/32 INCH TUBE, 90	2
23	177-95-005**	PIVOT, HOOD CYLINDER	1
23A	106-199-2**	SLEEVE-.625 X .380 X .500 INCH	1
24	135-590-2	PIN, CLEVIS 2 X 3/8 DIAMETER	1
25	135-424-2	PIN, HAIRPIN COTTER PIN-FOR	1
26	77-145-2**	WASHER, FLAT 3/8 INCH SPECIAL	1
27	74-622-3**	HEX HEAD CAP SCREW 3/8-16 X 1.25 INCH GRADE 8	1
28	108-230-2	VALVE, 5/32 IN-LINE FLOW CONTROL	2
29	16-450-2	TUBE, AIR 5/32 INCH OD	18
30	94-17-2	TIE-WIRE SUPPORTS STICK ON	2
31	20-3162-1	KIT, RIM SCAN COMPONENTS	1
32	125-493-1	SENSOR, BALANCER OUTER CAMERA (Now incl. with hood (item 1))	1
33	125-496-1	SENSOR, BALANCER OUTER CAMERA SUB-ASSEMBLY	1
34	179-82-2	SHIELD, OUTER LASER	1
35	69-1554-2	COVER, OUTER LASER	1
36	75-863-2	CAPTIVE SCREW 4-40X0.5 INCH	1
37	75-861-2	PAN HEAD MACHINE SCREW 4-40 X 1/2 INCH	1
38	75-862-2	PAN HEAD MACHINE SCREW 4-40X1 1/2 INCH	1
39	112-174-2	RETAINING RING, E STYLE 7/64	1
40	75-24-2	ROUND HEAD MACHINE SCREW 6-32 X .38 INCH	2
41	94-50-2	TIE-WIRE 15 INCH X .298 INCH	1
42	14-1629	BRACKET, SUPPORT / SHIELD	1
42A	141-110-2	EXTRUSION- 5/8 INCH X 5/8 INCH FOAM	9 IN.
43	75-401-2	TRUSS HEAD SHEET METAL SCREW 10 X 1/2 INCH	2
44	125-492-1	SENSOR, BALANCER INNER CAMERA	1
45	125-495-1	SENSOR, BAL INNER CAMERA SUB-ASSEMBLY	1
46	179-81-2	SHIELD, INNER LASER	1
47	69-1526-2	COVER, INNER LASER HOUSING	1
48	75-861-2	PAN HEAD MACHINE SCREW 4-40 X 1/2 INCH	1
49	75-862-2	PAN HEAD MACHINE SCREW 4-40 X 1 1/2 INCH	1
50	75-863-2	CAPTIVE SCREW 4-40 X 0.5 INCH	1
51	112-174-2	RETAINING RING, E STYLE 7/64	1
52	49-88-2	GASKET, CABLE SEAL	1
53	75-671-2	SOCKET BUTTON HEAD CAP SCREW 10-32 X 3/4 INCH	2
54	38-1283-3	CABLE, ENCODER/INNER CAMERA	1
55	38-954-2	CABLE, USB 2.0 A/B 2 METER	1

* For Bimba brand cylinders, securing hardware for cylinder is available as 21A (PIN-CYLINDER TRUNNION, 135-629-2) and 21B (SHCS 10-32X.50, 75-394-2). Use Loctite 7091 or 7649 primer and Loctite 242, 243 or 248 threadlocker on threads of screw.

** For Parker brand cylinders use kit 20-3754-2

*** If sleeve (item 23A) is not present, different cylinder pivot and attaching hardware was used. See older 12-30 rev. 04-16g for parts.

**** Redesigned mid-2017 for addition of a hood stop. If hood stop not present, new design tube assembly

HUNTER
Engineering Company

PPP-Paint Code Required
A/R-As Required
REF-Reference

11250 HUNTER DRIVE BRIDGETON, MO 63044

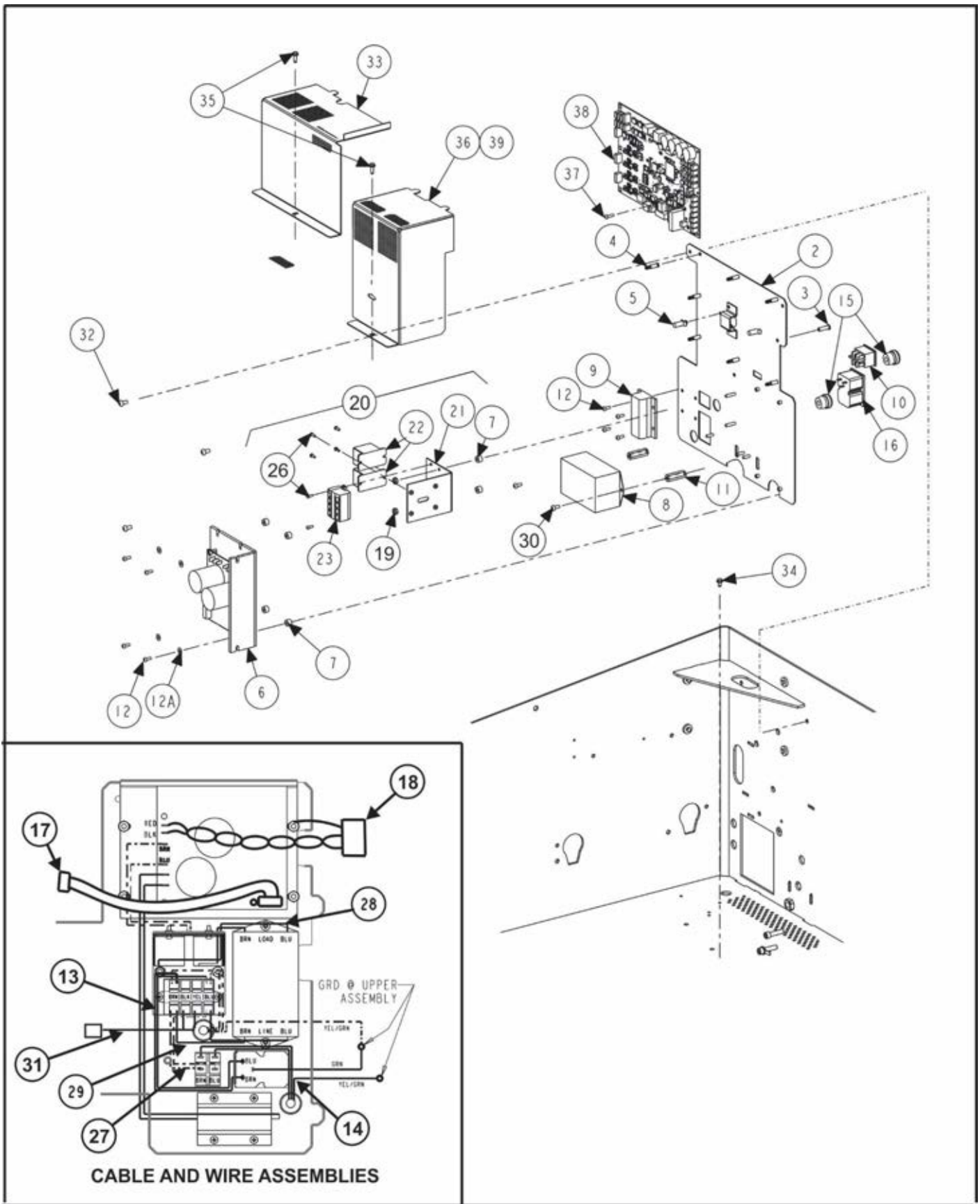

ELECTRIC PANEL

REFER TO NEXT SHEET FOR PARTS DESCRIPTION LISTING

PARTS DESCRIPTION LISTING

Index No.	Part Number	Description	Qty.
1	232-300-1	ELECTRIC PANEL, GEN5 BALANCER (Consisting Of:)	1
2	51-2929-1	PLATE ASSEMBLY, ELECTRONICS, GEN4 (Includes:)	1
3	46-750-2	SPACER, PRESS IN 6-32 X .75 INCH LONG	1
4	46-749-2	SPACER, SNAP TOP STANDOFF, .75	7
5	46-751-2	SPACER-NYLON PUSH IN .63 INCH HIGH	2
6	232-342-2*	DC MOTOR DRIVE, 230V/8A V2	1
7	46-704-2	SPACER #8 X .25 INCH LONG	4
8	136-108-2	FILTER, POWER LINE RFI	1
9	81-82-1	RESISTOR ASSEMBLY, 75 OHM WITH LEADS	1
10	18-270-2	SWITCH, DOUBLE PULL SINGLE THROW ROCKER	1
11	46-705-2	STANDOFF, 3/8 HEX, 8-32 X 1-1/4 INCH	2
12	75-24-2	ROUND HEAD MACHINE SCREW 6-32 X .38 INCH	8
12A	77-12-2	WASHER, LOCK #6 INTERNAL LOCK	4
13	38-1215-2	POWER CORD, SPLIT IEC	1
14	38-845-3	CABLE ASSEMBLY, POWER GSP9700	1
15	59-62-2	STRAIN RELIEF, HEYCO #1244	2
16	36-67-1	RECEPTACLE ASSEMBLY, GEN4 BAL	1
17	38-1023-1	CABLE ASSEMBLY, 9200 POWER SUPPLY	1
18	37-628-1	WIRE ASSEMBLY, MOTOR	1
19	76-71-2	NUT-KEPS 8-32	2
20	232-277-1	ELECTRIC ASSEMBLY-BALANCER, RELAY (Consisting Of:)	1
21	14-1507-1	BRACKET ASSEMBLY, BALANCER RELAY	1
22	18-571-2	RELAY, BALANCER DC DRIVE	2
23	19-282-2	TERMINAL STRIP, 4 COND, 4 POLE	1
24	37-477-1	WIRE ASSEMBLY, 9700 POWER SWITCH (Not Illustrated)	1
25	37-656-1	WIRE ASSEMBLY, BALANCER RELAY POWER SPLIT (Not Illustrated)	1
26	75-171-2	ROUND HEAD MACHINE SCREW 4-40 X 5/16 INCH	6
27	37-652-1	WIRE ASSEMBLY, GEN4 BALANCER POWER SWITCH	1
28	37-633-1	WIRE ASSEMBLY, BALANCER RELAY TO DRIVE	1
29	37-657-1	WIRE ASSEMBLY, BALANCER TERMINAL TO FILTER	1
30	75-32-2	ROUND HEAD MACHINE SCREW 8-32 X 3/8 INCH	2
31	37-694-1	WIRE ASSEMBLY, GEN5 BALANCER RELAY POWER	1
32	75-802-2	SCREW, SELF-TAPPING 10-32 X 3/8 INCH	4
33	69-1409	COVER, ELECTRONICS, LEFT-HAND	1
34	75-682-2	SCREW, SELF-TAPPING 8-32 X 5/16 INCH GREEN	1
35	75-327-2	SCREW, SELF-TAPPING 8-32 X 1/2 INCH	2
36	69-1564	COVER, ELECTRONICS, RIGHT-HAND	1
37	75-49-2	ROUND HEAD MACHINE SCREW 6-32 X 1/2 INCH	1
38	45-1513-1	PCA, BALANCER DAQ-USB	1
and	21-204-2	CONNECTOR .1 2 CIRCUIT JUMPER (S3) (Not Shown) (removed 4/17 – software fix)	1
39	113-258-2	BUSHING, PUSH ON TRIM	1.25 in

* Replacing 232-205-2 (DC MOTOR DRIVE, 230V/8A) in late 2019.

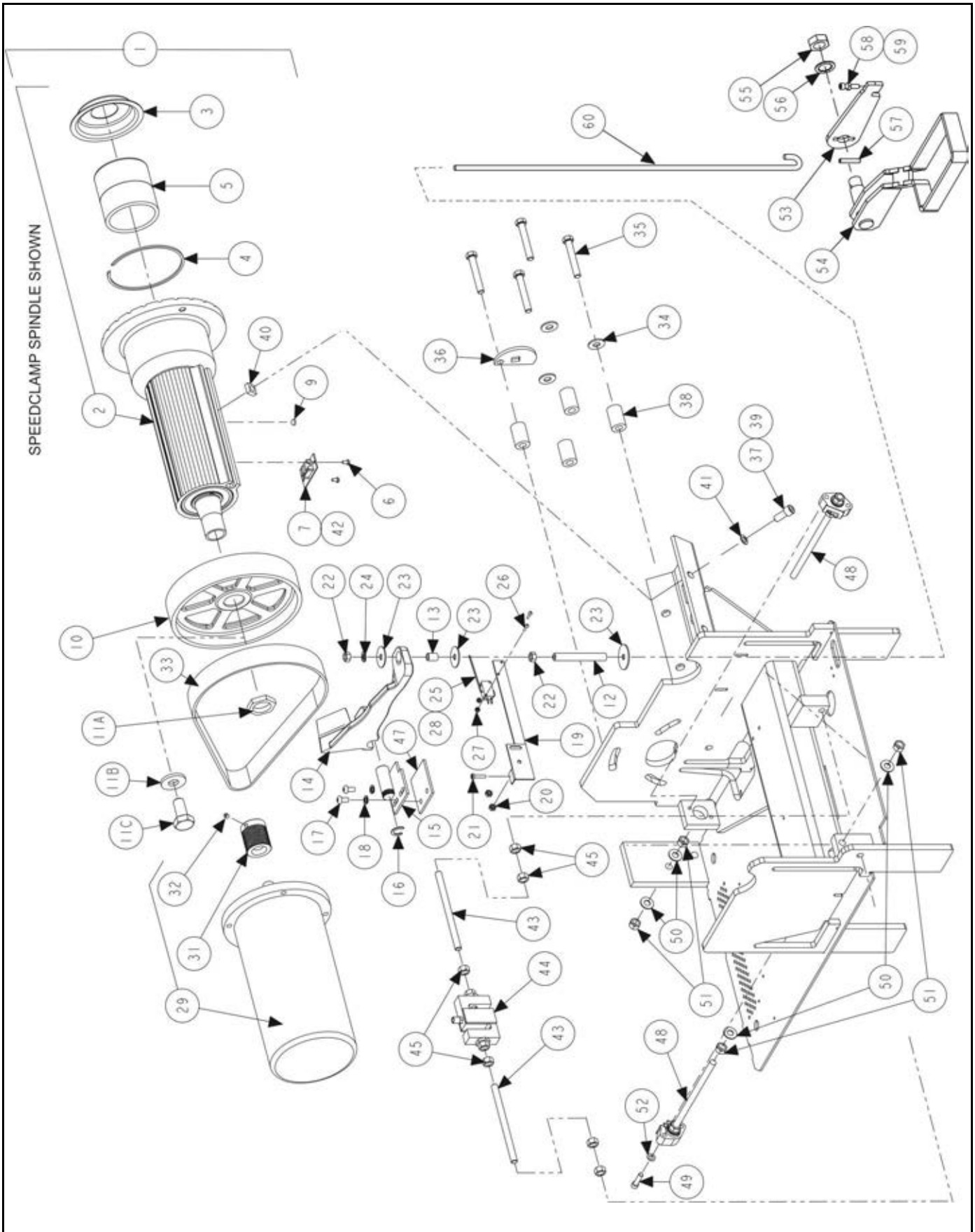

VIBRATION STRUCTURE

REFER TO NEXT SHEET FOR PARTS DESCRIPTION LISTING

PARTS DESCRIPTION LISTING

Form 12-30, 09-19

Sheet 7 of 14

Index No.	Part Number	Description	Qty.
1	105-689-1	HOUSING, SPINDLE W/ DIFF ENCODER (For Speed-Clamp) (Consists Of:)	1
OR	105-677-1	HOUSING, SHAFT W/ DIFF ENC (NOT For Speed-Clamp) (Not Ill.) (Cons. Of:)	1
AND	97-531-2*	SHAFT-THREADED, REMOVABLE (export only) (Not Illustrated)	1
2	105-486-1	HOUSING, SPINDLE / DRIVE ASSEMBLY (For Speed-Clamp) (Includes:)	1
OR	105-541-1	HOUSING, SOLID SHAFT (NOT For Speed-Clamp) (Not Illustrated) (Includes:)	1
3	41-221-2	RETAINER, SPRING COVER	1
4	112-112-2	SNAP RING, INTERNAL 115 mm	1
5	98-381-2	SPRING, CONE	1
6	75-152-2	PAN HEAD MACHINE SCREW 8-32 X 5/16 INCH	2
7	45-1531-1	PCB, SPINDLE ENCODER DIFF OUT	1
8	53-238-2	PLUG, PLASTIC FOR .75 INCH HOLE	1
10	107-133-2	PULLEY, DRIVEN 14 RIB	1
11A	76-470-2	NUT, AUTOCLAMP PULLEY NUT (For Speed-Clamp)	1
11B	77-239-2	WASHER, FLAT 5/8 INCH SPECIAL (NOT For Speed-Clamp)	1
11C	74-365-2	HEX HEAD CAP SCREW M16-2X35 mm GRADE 8.8 (NOT For Speed-Clamp)	1
12	98-416-2	SPRING, BRAKE RELEASE	1
13	106-155-2	SLEEVE, BRAKE ISOLATOR	1
14	164-124-1	LEVER, SPINDLE BRAKE ASSEMBLY, WIDE	1
15	177-67-1-005	PIVOT, SPINDLE BRAKE ASSEMBLY	1
16	112-21-2	SNAP RING-#5103-75	1
17	75-120-2	ROUND HEAD MACHINE SCREW 1/4 - 20 X .63 INCH GRADE 8	2
18	77-71-2	WASHER, LOCK 1/4 INCH HELICAL SPRING	2
19	14-1132	BRACKET, FOOTBRAKE SWITCH	1
20	76-61-2	NUT, KEPS 10-32	2
21	75-414-2	PAN HEAD MACHINE SCREW 8-32 X 3/4 INCH	1
22	76-37-2	NUT, HEX 5/16-18	2
23	77-180-2	WASHER, FENDER 5/16 INCH	3
24	77-60-2	WASHER, LOCK 5/16 INCH HELICAL SPRING	1
25	18-454-2	SWITCH, MINI SINGLE-PULL DOUBLE-THROW 2.93 INCH LEVER	1
26	75-75-2	ROUND HEAD MACHINE SCREW 4-40 X 5/8 INCH	2
27	76-366-2	NUT, KEPS 4-40	2
28	38-1026-1	CABLE ASSEMBLY, SPINDLE LOC	1

* Use Shaft, 97-531-2, and Housing, 105-689-1 together for non-speed-clamp export models

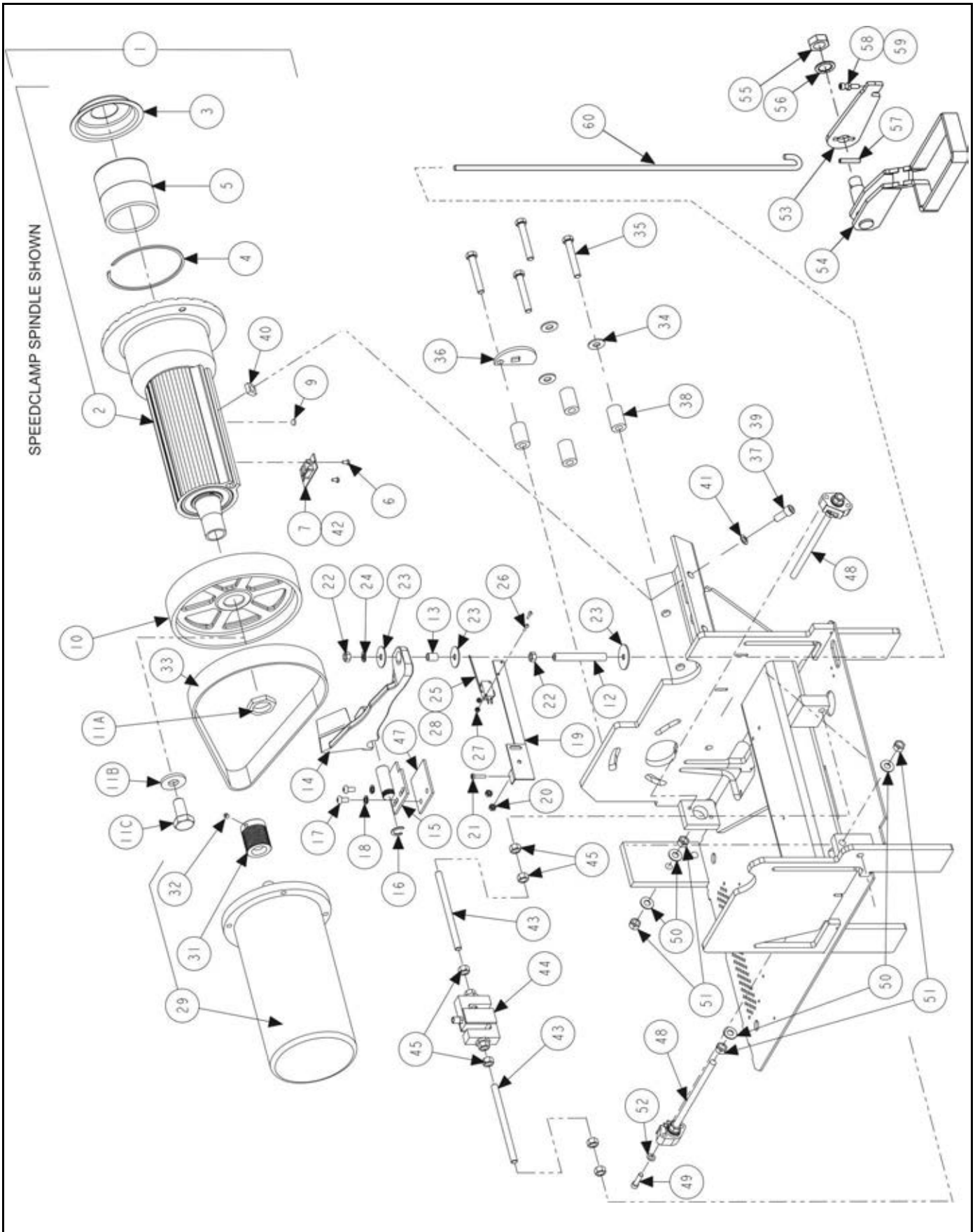

VIBRATION STRUCTURE (continued)

REFER TO NEXT SHEET FOR PARTS DESCRIPTION LISTING

PARTS DESCRIPTION LISTING

Form 12-30, 09-19

Sheet 8 of 14

Index No.	Part Number	Description	Qty.
29	129-270-1	MOTOR ASSEMBLY, DC, RS BALANCER (Includes:)	1
30	55-18-2	CORE, FERRITE (CYLINDRICAL) (Not Illustrated)	1
31	107-134-2	PULLEY, DRIVE, 14 GROOVE	1
32	75-66-2	SOCKET SET SCREW 1/4-20 X 1/4 INCH CUP POINT	2
33	126-50-2	BELT, POLY-V DRIVE, 14 RIB	1
34	77-66-2	WASHER, FLAT 3/8 TYPE A-W	3
35	74-207-2	HEX HEAD CAP SCREW 3/8-16 X 3 INCH	4
36	172-34-2	CAM, BELT TENSIONER	1
37	FIELD PURCHASE	ADHESIVE, THREAD LOCKING (LOCKTITE 222)	A/R
38	46-422-2	SPACER, MOTOR	4
39	74-59-2	HEX HEAD CAP SCREW, 3/8-16 X .75 INCH (FULL-THREAD)	4
40	76-428-2	NUT, 3/8-16, .615 INCH SQUARE X .25 INCH	4
41	77-297-2	WASHER, FLAT 3/8 INCH	4
42	38-1265-3	CABLE ASSEMBLY, SPINDLE ENCODER DIFF	1
43	63-256-2	ROD, THREADED 3/8-24 X 5.5 INCH	2
44	109-100-1	TRANSDUCER, 500# S-CELL WITH CONNECTIONS	1
45	76-485-2	NUT, HEX 3/8-24 GRADE 8	6
46	FIELD PURCHASE	ADHESIVE, MEDIUM THREAD LOCKING (LOCKTITE 242)	A/R
47	46-686-005	SPACER, BRAKE PIVOT - A	1
48	109-155-1	TRANSDUCER ASSEMBLY, GEN IV BALANCER	2
49	75-239-2	SOCKET HEAD CAP SCREW 1/4-20 X 1.00 INCH (FULL-THREAD)	4
50	77-373-2	WASHER, FLAT 3/8 INCH, GRADE 8	4
51	76-485-2	NUT, HEX 3/8-24, GRADE 8	4
52	77-381-2	WASHER, .26 ID x .49 OD x .035 INCH	2
53	164-119-005	LEVER, BRAKE	1
54	177-90-1-005	PIVOT, BRAKE WELDMENT	1
55	76-108-2	NUT, JAM 3/4-16	1
56	77-50-2	WASHER-LOCK 3/4 INCH INTERNAL TOOTH	1
57	135-436-2	PIN-DOWEL 1/4 X 1 3/8 INCH HARDENED	1
58	75-239-2	SOCKET HEAD CAP SCREW 1/4-20 X 1.00 INCH (Full-Thread)	1
59	76-51-2	NUT, JAM 1/4-20	1
60	63-295-2	ROD, BRAKE ACTUATOR SHORT	1

Items 1 – 28 are located on previous sheet.

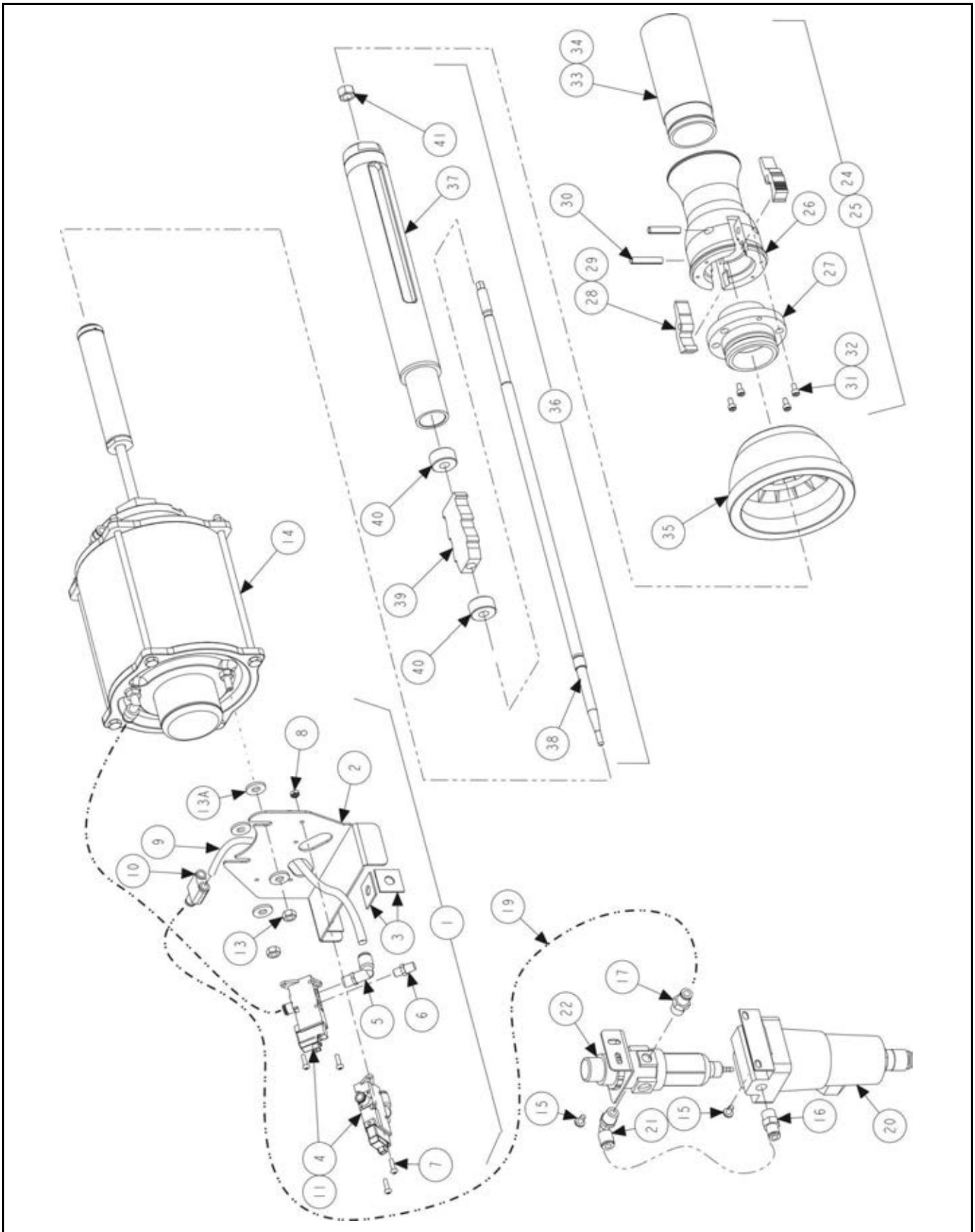

SPEEDCLAMP FEATURE

REFER TO NEXT SHEET FOR PARTS DESCRIPTION LISTING

PARTS DESCRIPTION LISTING

Form 12-30, 09-19

Sheet 9 of 14

Index No.	Part Number	Description	Qty.
1	14-1659-1	BRACKET, ASSEMBLY, SPEEDCLAMP RFT VALVE (Consisting Of:)	1
2	14-1640-005*	BRACKET, ANTI ROTATE SPEEDCLAMP	1
3	49-84-2*	GASKET-TC REAR PANEL	4
4	108-198-2	VALVE-PNEUMATIC SOLENOID	2
5	145-358-2*	FITTING, 1/8 INCH NPT - 1/4 INCH PTC ELBOW	2
6	145-503-2*	FITTING, 1/16 INCH NPT EXHAUST SILENCER	2
7	75-49-2	ROUND HEAD MACHINE SCREW 6-32 X 1/2 INCH	4
8	76-84-2	NUT-KEPS 6-32	4
9	16-843-2	TUBE, 1/4 INCH HOSE, FLEXIBLE	33.25 in
10	145-325-2	FITTING, 1/4 INCH Y	1
11	38-1094-1	CABLE, MANIFOLD ASSEMBLY	2
12	94-31-2	TIE-CABLE (BLU) (Not Illustrated)	3
13	76-368-2	NUT, LOCK 1/4-20 NYLON INSERT	2
13A	77-67-2	WASHER-FLAT 1/4 INCH	4
14	20-3176-1*	KIT, RP-SPEEDCLAMP (Cylinder ONLY available as complete RP kit.)*	1
15	75-522-2	SCREW, SELF TAPPING 10-32 X .38 INCH	2
16	145-273-2	FITTING, 1/4 INCH HOSE X 1/4 NPT	1
17	145-324-2	FITTING, 1/8 NPT TO 1/4 INCH TUBE, 90	1
18	145-281-2	FITTING, 1/4 INCH HOSE X 1/8 NPT (Not Illustrated)	2
19	16-843-2	TUBE, 1/4 INCH HOSE, FLEXIBLE	33.5 in.
20	136-94-2	FILTER / REGULATOR, GSP AUTOCLAMP	1
21	145-350-2	FITTING, 1/4 TUBE-1/4 NPT 90 ELBOW	1
22	136-78-2	FILTER / REGULATOR, GSP9700 (supplied with roller)	REF.
23	137-96-1	HOSE ASSEMBLY, PNEUMATIC SUPPLY (Not Illustrated)	REF.
23A	145-466-2	FITTING-AIR SWIVEL 1/4 PIPE (Not Illustrated)	1
24	20-3195-1	KIT, HUB ASSEMBLY, SPEEDCLAMP (Consisting Of:)	1
OR	20-3196-1	KIT, HUB ASSEMBLY, SPEEDCLAMP – EXPORT (Consisting Of:)	1
25	184-106-1	HUB ASSEMBLY, SPEEDCLAMP (Consists Of:)	1
26	184-105-2	HUB, SPEEDCLAMP CUP	1
27	217-61-2	COLLAR, AUTO-CLAMP CUP	1
28	144-105-2	LINK, PAWL AUTO-CLAMP	2
29	98-422-2	SPRING, TORSION AUTO-CLAMP	2
30	135-121-2	PIN, ROLL 1/4 INCH X 1 1/4 INCH	2
31	75-306-2	SOCKET HEAD CAP SCREW 8-32 X .31 INCH	4
32	Field purchase	LOCTITE # 271 OR PERMA BOND # HM128	A/R
33	106-156-2	SLEEVE, CLAMP (Export Only)	1
34	124-165-2	SEAL, O RING AS568A-030 (Export Only)	1
35	175-353-1	ADAPTOR, BALANCER CUP WITH RETAINER	REF
36	97-587-1	SHAFT ASSEMBLY, OUTER 40 mm AUTO-CLAMP (Consists Of:)	1
37	97-586-2	SHAFT, OUTER AUTO-CLAMP	1
38	97-585-2	SHAFT, OUTER WITH HEX	1
39	99-132-2	RATCHET, AUTO-CLAMP	1
40	113-280-2	BUSHING, OUTER SHAFT	2
41	76-458-2	NUT, GRIP 3/8-24	1

* Kit 20-3176-1 (Replacement Part - SpeedClamp Kit) contains identified items and instructions, Form 7076-T.

HUNTER
Engineering Company

11250 HUNTER DRIVE BRIDGETON, MO 63044

PPP-Paint Code Required
A/R-As Required
REF-Reference

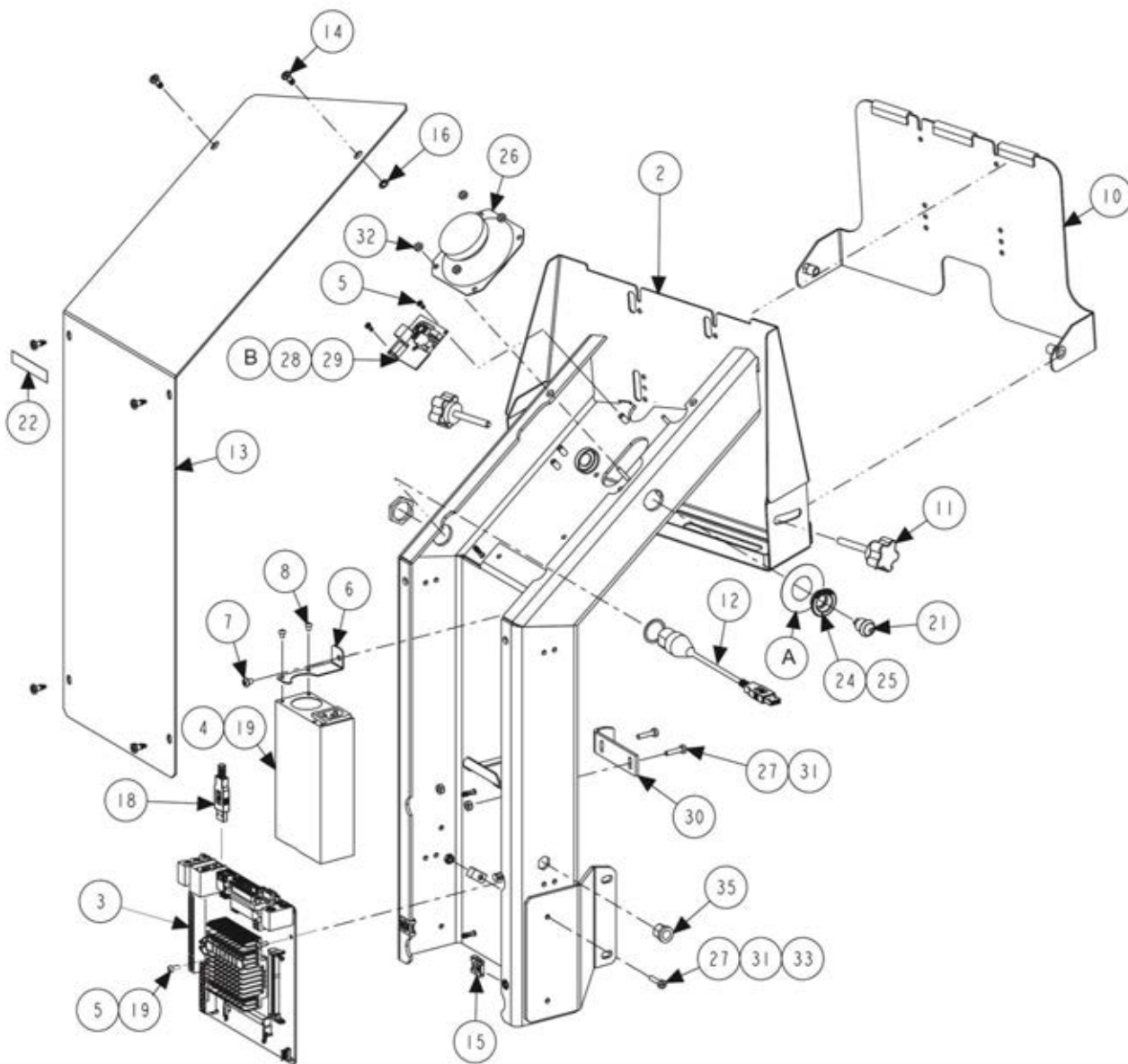

TOUCH SCREEN SUPPORT

REFER TO NEXT SHEET FOR PARTS DESCRIPTION LISTING

PARTS DESCRIPTION LISTING

Index No.	Part Number	Description	RFE Qty.
1	11-1786-1*	ASSEMBLY DISPLAY SUPPORT RFE (Consisting Of:)	1
2	11-1784-1-005	ASSEMBLY - DISPLAY SUPPORT, BALANCER	1
3	45-1545-2	PCB - J1900 Mini-ITX motherboard	1
4	232-373-2 / 20-3744-1	FLEX ATX 150W POWER SUPPLY / KIT - RETROFIT*****	1
5	75-24-2	ROUND HEAD MACHINE SCREW 6-32 X .38 INCH	3
6	14-1307	BRACKET - FLEX ATX	1
7	75-582-2	SOCKET BUTTON HEAD CAP SCREW -10-32 X .25 INCH	1
8	75-332-2	ROUND HEAD MACHINE SCREW 6-32 X .19 INCH	2
9	46-790-2	STANDOFF- 0.437 INCH HIGH, NYLON (Part removed 03-19)	0
10	171-349-1	ASSEMBLY - PANEL, DISP MT, TILTABLE	1
11	34-208-2	KNOB - 1/4-20 X 1/2 INCH	2
12	38-1337-2	CONNECTOR - USB-A BULKHEAD TO HEADER	1
13	69-1372-005	COVER - DISPLAY SUPPORT, TOUCH (Older version had vent holes.)	1
14	75-775-2	SCREW - QUARTER TURN, SIZE 280	6
15	76-490-2	NUT - QUARTER TURN, CLIP-ON	6
16	41-205-2	RETAIN - QUARTER-TURN, 82 SERIES	6
17	75-735-2	SCREW - PAN HEAD MACHINE SCREW #6-32 X .56 INCH	4
18	38-963-2	CABLE - USB 2.0 A/B 1METER	1
19	37-704-1	WIRE ASSEMBLY - DAQ TO POWER, 4 PIN EXT	1
20	94-45-2	TIE-CABLE (BLK)	4
21	18-565-2	SWITCH ASSEMBLY - BALANCER MOTHER BOARD POWER	1
22	128-1399-2	DECAL - DISPLAY COVER GEN IV	1
23	BLD-DRIVES	PROGRAM AND DATA FLASH DRIVES (Not Illustrated)	1
24	105-639-2	HOUSING - POWER BUTTON, OUTER	1
25	105-640-2	HOUSING - POWER BUTTON, INNER	1
A	128-1817-2	DECAL - BALANCER POWER OFF	1
26	109-173-1	SPEAKER ASSEMBLY - 3.5 INCH W CABLE	1
27	76-71-2	NUT - KEPS 8-32	3
28	45-1695-1****	PCA - MONO AUDIO AMP G3	1
29	37-653-1	WIRE ASSEMBLY - TC AUDIO AMP POWER	1
B	38-768-2	CABLE-STEREO JUMPER	1
30	216-118-005	HOOK - WEIGHT TRAY	1
31	75-414-2	PAN HEAD MACHINE SCREW 8-32 X .75 INCH	3
32	76-84-2	NUT - KEPS 6-32	4
33	12-145-2	CLAMP - CABLE 1/4 INCH DIAMETER	1
34	38-1287-2	CABLE- USB BULKHD, FEMALE-.75M (Part removed 02-19)	2
35	76-296-2	NUT - INSERT 3/8-16 HEX	1
36	75-758-2**	SOCKET BUTTON HEAD CAP SCREW 1/4-20 X .63 INCH (Not Illustrated)	4
37	76-414-2**	NUT - HEX INSERT 1/4-20 (Not Illustrated)	4
38	227-109-2***	DISPLAY, 22 INCH LCD WITH RESISTIVE TOUCH (Not Illustrated)	1
OR	227-105-2	DISPLAY, 22 INCH LCD WITH TOUCH (Not Illustrated)	1
39	75-668-2	PAN HEAD MACHINE SCREW M4 X .7 X 10 mm (Not Illustrated)	2

* See previous 09-18a version of balancer parts drawing for previous display support with piano-style hinge.

** Hardware to attach support to tub. (Not Illustrated)

*** Resistive touch monitors ship standard as of 2/6/2017; require software version 3.0.1.488 or later.

**** Shown board appeared early 2020. Previous Audio boards were 45-1623-1 and 45-1451-1. Location of board moved from the upper, vertical surface in mid 2020.

***** To replace previous power supply with new 232-373-1, use kit 20-3744-1. Kit contains needed retrofit bracket.



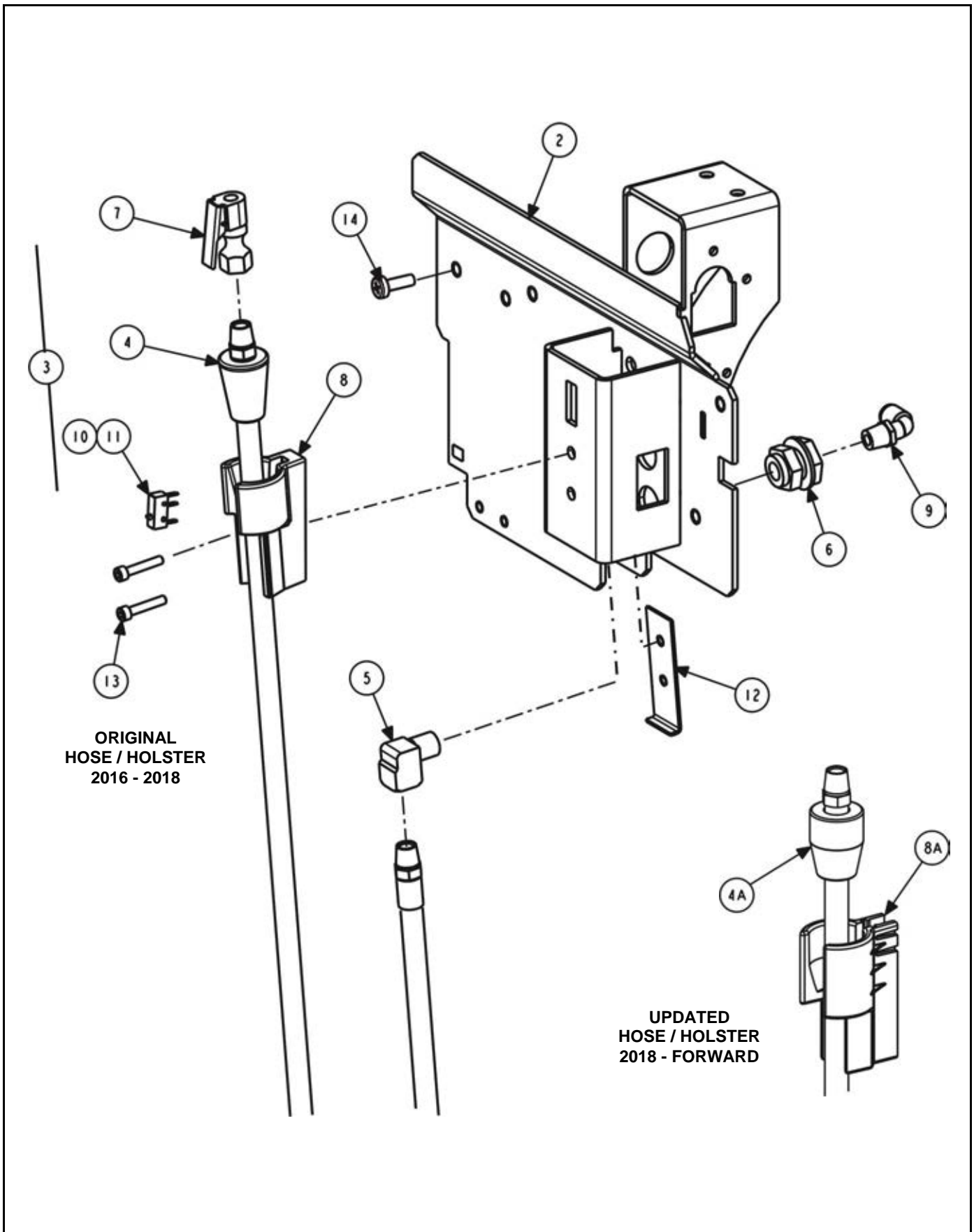

INFLATION SUPPORT ASSEMBLY, 11-1633-1

REFER TO NEXT SHEET FOR PARTS DESCRIPTION LISTING

PARTS DESCRIPTION LISTING

ORIGINAL VERSION - OBSOLETE

Index No.	Part Number	Description	Qty.
1	11-1633-1	SUPPORT ASSEMBLY, INFLATION (Consists Of:)	1
2	11-1632-1-005	SUPPORT ASSEMBLY, INFLATION	1
3	105-648-1	HOUSING ASSEMBLY, BALANCER TIRE FILL (Consists Of:)	1
4*	137-149-1	HOSE ASSEMBLY, BALANCER TIRE FILL (Includes)	1
5	145-241-2	FITTING, 1/4 BRASS STREET ELBOW	1
6	145-224-2	COUPLING, BULKHEAD	1
7	145-341-2	FITTING, AIR CHUCK LOCK-ON OPEN	1
8*	105-645-1	HOUSING, TC INFLATION HOLSTER	1
9	145-350-2	FITTING, 1/4 INCH TUBE-1/4 INCH NPT 90 ELBOW	1
10	18-350-2	SWITCH, SUBMINIATURE LIMIT (included with holster (item 8))	REF
11	37-481-1	WIRE ASSEMBLY-GSP9700 TIRE FILL	1
12	14-1514-1	BRACKET ASSEMBLY-INFLATION MOUNT	1
13	75-436-2	SOCKET HEAD CAP SCREW 10-32 X 1.00 INCH (FULL-THREAD)	2
14	75-128-2	PAN HEAD MACHINE SCREW 1/4-20 X 3/4 INCH	4

UPDATE 2018 VERSION

Index No.	Part Number	Description	Qty.
1	11-1633-1	SUPPORT ASSEMBLY, INFLATION (Consists Of:)	1
2	11-1632-1-005	SUPPORT ASSEMBLY, INFLATION	1
3A	105-728-1	HOUSING ASSEMBLY, BALANCER TIRE FILL (Consists Of:)	1
4A*	137-156-1	HOSE ASSEMBLY, BALANCER TIRE FILL 60 INCH (Includes)	1
5	145-241-2	FITTING, 1/4 BRASS STREET ELBOW	1
6	145-224-2	COUPLING, BULKHEAD	1
7	145-341-2	FITTING, AIR CHUCK LOCK-ON OPEN	1
8A*	105-721-1	ASSEMBLY, INFLATION STATION (includes)	1
10	18-350-2	SWITCH, SUBMINIATURE LIMIT	1
9	145-350-2	FITTING, 1/4 INCH TUBE-1/4 INCH NPT 90 ELBOW	1
11	37-481-1	WIRE ASSEMBLY-GSP9700 TIRE FILL	1
12	14-1514-1	BRACKET ASSEMBLY-INFLATION MOUNT	1
13	75-436-2	SOCKET HEAD CAP SCREW 10-32 X 1.00 INCH (FULL-THREAD)	2
14	75-128-2	PAN HEAD MACHINE SCREW 1/4-20 X 3/4 INCH	4

* Holster (8 and 8A) and hose (items 4 and 4A) need both upgraded together. Old and new do not work well together.

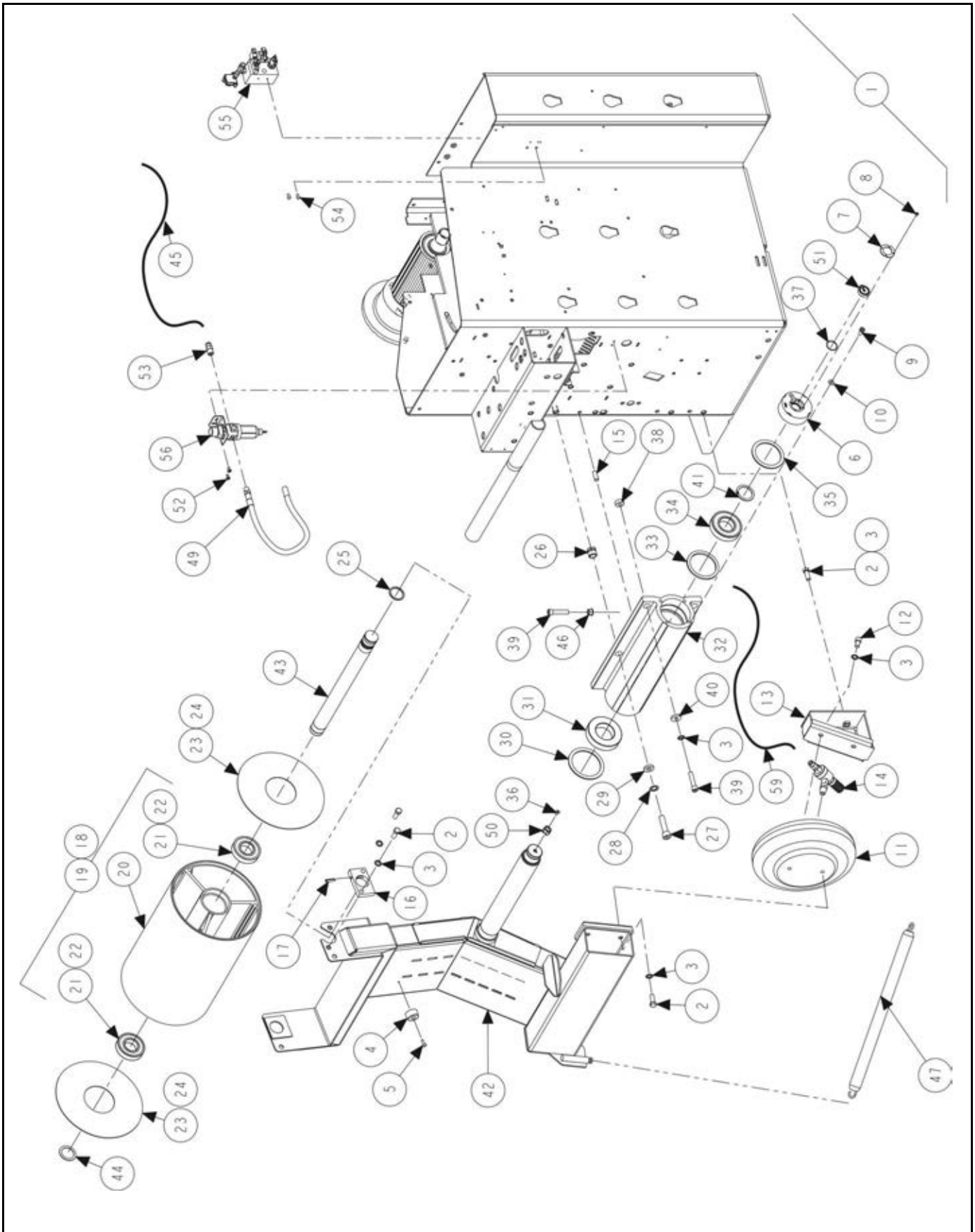

LOAD ROLLER

REFER TO NEXT SHEET FOR PARTS DESCRIPTION LISTING

PARTS DESCRIPTION LISTING

Index No.	Part Number	Description	Qty.
1	111-156-1	ROLLER ASSEMBLY, RIM SCAN (Consisting Of:)	1
2	74-105-2	HEX HEAD CAP SCREW 3/8-16 X 1.00 INCH, GRADE 5 (FULL-THREAD)	6
3	77-21-2	WASHER, LOCK 3/8 INCH INTERNAL TOOTH	10
4	62-51-2	FOOT, PLASTIC 1.06 OD X 0.44 INCH HEIGHT (LIKELY NOT PRESENT)	1
5	75-476-2	TRUSS HEAD SHEET METAL SCREW 10 X 3/4 INCH (LIKELY NOT PRESENT)	1
6	113-197-2	BUSHING, LRO SENSOR	1
7	41-112	RETAINER, INNER DATASET	1
8	75-423-2	SCREW, SELF TAPPING 4-40 X .38 INCH	4
9	75-128-2	PAN HEAD MACHINE SCREW 1/4-20 X 3/4 INCH	4
10	77-67-2	WASHER, FLAT 1/4 INCH	4
11	98-283-2	SPRING, AIR ACTUATOR	1
12	74-220-2	SOCKET HEAD CAP SCREW 3/8-16 X .63 INCH (FULL-THREAD)	2
13	14-1162-1-005	BRACKET, AIRBAG	1
14	108-148-2	VALVE, QUICK EXHAUST W MUFFLER	1
15	135-333-2	PIN, DOWEL 3/8 X 1.00 INCH LONG	1
16	57-653-005	BAR, SHAFT ROLLER	1
17	135-53-2	PIN, ROLL 1/4 X 1 INCH	1
18	111-90-3	ROLLER, LOADED RUNOUT (Consisting Of:)	1
19	162-128-2	TAPE, NONSKID TREAD 24 INCH TRIMMED	1
20	111-94-2	ROLLER, LOADED RUNOUT	1
21	130-169-2	BEARING 35 mm X72 mm	2
22	Field Purchase	LOCTITE RETAINING COMPOUND #609	A/R
23	69-1030	COVER, LOAD ROLLER END	2
24	Field Purchase	TAPE, 3M 4920 DOUBLE COATED FOAM	6
25	112-109-2	SNAP RING, EXTERNAL WAVE 1.375 INCH	1
26	74-420-2	BOLT, LEVELING .81-12 OUTER DIAMETER X .59 INNER DIAMETER	2
27	74-206-2	SOCKET HEAD CAP SCREW 1/2-13 X 2.00 INCH (FULL-THREAD)	2
28	77-22-2	WASHER, LOCK 1/2 INCH INTERNAL TOOTH	2
29	77-295-2	WASHER, .515 X 1.00 X .19 INCH THICK	2
30	112-110-2	SNAP RING INTERNAL, 90.5 mm DIAMETER	1
31	130-170-2	BEARING, 50 mm INNER DIAMETER X 90 mm OUTER DIAMETER	1
32	105-401-2	HOUSING, LOAD ROLLER BEARING	1
33	112-111-2	SNAP RING, SMALLEY WHW-312	1
34	130-137-2	BEARING, 40 mm INNER DIAMETER X 80 mm OUTER DIAMETER	1
35	112-106-2	SNAP RING, TRUARC 5008-315	1
36	75-508-3	FLAT HEAD MACHINE SCREW 10-32X.50 INCH	1
37	124-117-2	O-RING .989 INNER DIAMETER X .070 INCH	1
38	46-504-2	SPACER, 7/16 X 7/8 X 5/16 INCH THICK	2
39	74-418-2	SOCKET HEAD CAP SCREW 3/8-16 X 2.00 INCH	3
40	77-296-2	WASHER, .407 X 1.00 X .19 INCH THICK	2
41	112-79-2	SNAP RING, EXTERNAL, 1-9/16 INCH DIAMETER	1
42	103-296-1-005	ARM, LOADED RUNOUT, GEN 5	1
43	97-450-2	SHAFT, ROLLER	1
44	112-83-2	SNAP RING, TRUARC 5108-137	1
45	16-321-2	TUBE, 5/16 INCH OUTER DIAMETER	3 ft.
46	76-159-2	NUT, KEPS 3/8-16	1
47	98-303-2	SPRING, HOOD	1
48	128-603-2	DECAL, AIR PRESSURE LIMITS (Not Illustrated)	1
49	137-96-1	HOSE ASSEMBLY, PNEUMATIC SUPPLY	1
50	176-35-1	LOCATOR ASSEMBLY, MAGNET	1
51	125-395-3	SENSOR, HALL, LOAD ROLLER	1
52	75-522-2	SCREW, SELF-TAPPING 10-32 X .38 INCH	2
53	145-184-2	FITTING, 1/4 INCH NPT ADAPTOR	1
54	75-248-2	ROUND HEAD MACHINE SCREW 10-24 X 3/8 INCH	2
55	108-274-1	PNEUMATIC ASSEMBLY, BALANCER, HIGH-FLOW (See Sheet 13)	1
OR	108-281-1	PNEUMATIC ASSEMBLY, BALANCER, HIGH-FLOW (See Sheet 13)	1
56	136-78-2	FILTER / REGULATOR, GSP9700	1
AND	145-466-2	FITTING-AIR SWIVEL 1/4 PIPE (DISCOUNT TIRE ONLY)	1
57	145-399-2	FITTING, REDUCER 5/16 - 1/4 INCH TUBE	1
58	113-179-2	BUSHING, BRAKE ACTUATOR ROD (Not Illustrated)	1
59	16-423-2	TUBE, .172 INCH INNER DIAMETER	98 in.

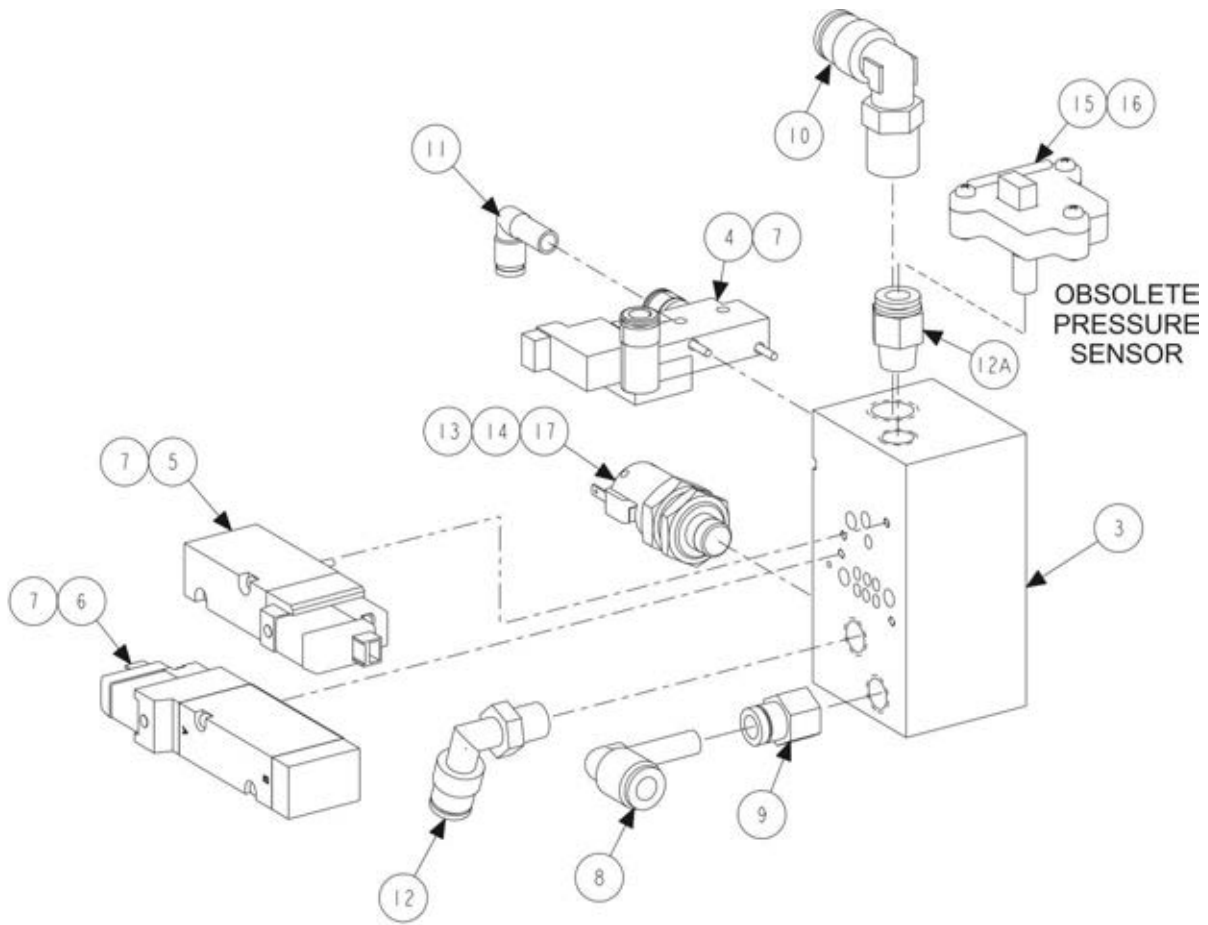

OBSOLETE
PRESSURE
SENSOR

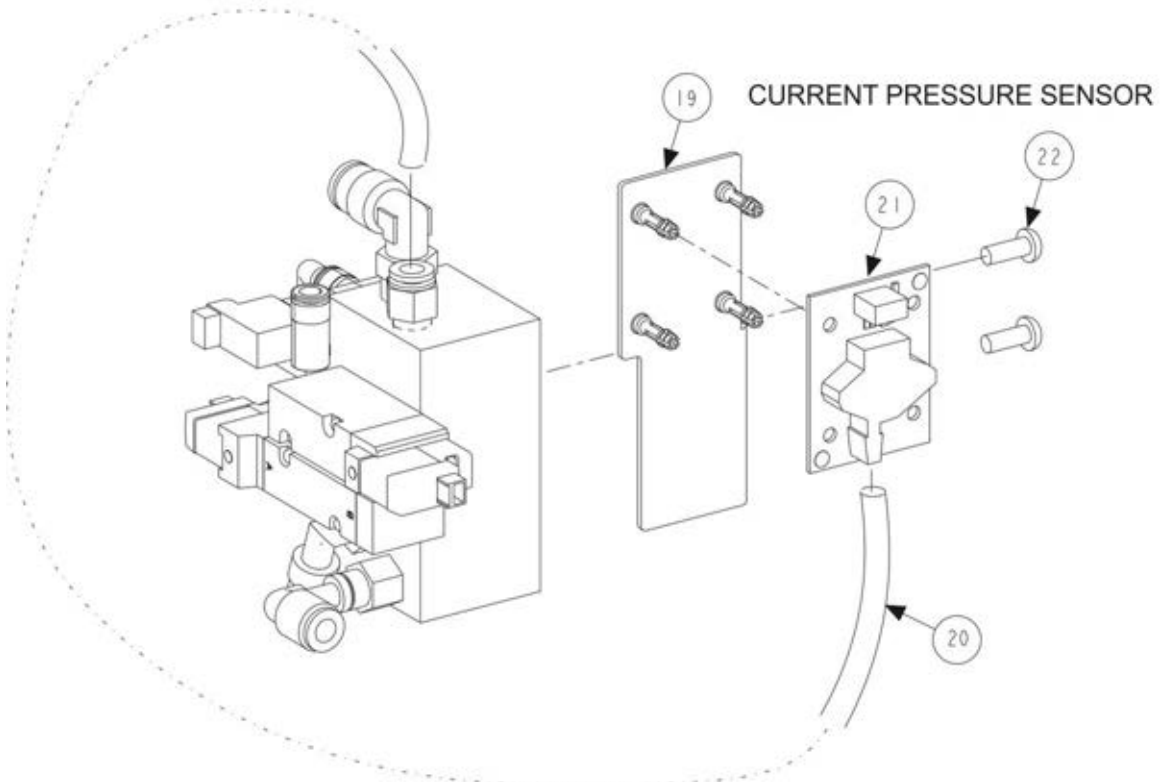

CURRENT PRESSURE SENSOR

LOAD ROLLER MANIFOLD

REFER TO NEXT SHEET FOR PARTS DESCRIPTION LISTING

PARTS DESCRIPTION LISTING

Index No.	Part Number	Description	Qty.
	108-281-1	PNEUMATIC ASSEMBLY-BALANCER, HIGH FLOW – CURRENT (Cons Of:)	1
	108-274-1	LOAD ROLLER PNEUMATIC ASSEMBLY, BALANCER, - OBS. (Cons Of:)	1
3	185-42-2	MANIFOLD, PNEUMATIC, HIGH-FLOW (Not Available)	1
4	108-195-2	VALVE, 3 PORT MANIFOLD MT.	1
5	108-260-2	VALVE, PNEUMATIC SOLENOID	1
6	108-276-2	VALVE, 5 PORT MANIFOLD MT	1
7	38-1094-1	CABLE, MANIFOLD ASSEMBLY	3
8	145-357-2	FITTING, 1/4 INCH PLUG-IN ELBOW	1
9	145-281-2	FITTING, 1/4 HOSE X 1/8 INCH NPT	1
10	145-183-2	FITTING, 1/4 INCH NPT ELBOW SWIVEL	1
11	145-467-2	FITTING, 1/4 TO 5/32 PLUG-IN ELBOW	1
12	145-324-2	FITTING, 1/8 NPT TO 1/4 INCH TUBE 90	2
12A	145-354-2	FITTING-1/4 TUBE-1/8 NPT	1
13	18-600-2	SWITCH, PRESSURE- 65 PSI	1
14	38-1164-1	CABLE ASSEMBLY, DAQ TO INFLATION PRESS SW	1
15*	125-465-1*	SENSOR, PRESSURE (OBSOLETE, SEE ITEMS 19 - 22)*	1
16	38-1202-1	CABLE ASSEMBLY, TC PRESSURE/TEMPATURE SENSOR (108-274-1 Only)	1
17	Field Purchase	LOCTITE #545 THREAD SEALANT	A/R

* Use Balancer Pressure Sensor Kit 20-3429-1 to replace item 15. See Form 7440-T for details.

CURRENT PRESSURE SENSOR COMPONENTS

Index No.	Part Number	Description	Qty.
18	20-3429-1	BALANCER PRESSURE SENSOR KIT (Consisting Of:)	1
19	14-1724-1	BRACKET ASSEMBLY-SENSOR MANIFOLD	1
20	16-423-2	TUBE, AIR 1/4 INCH OD	30
21	45-1645-1	PCA, PRESSURE SENSOR G2	1
22	75-19-2	ROUND HEAD MACHINE SCREW 10-24 X 1/2 INCH	2

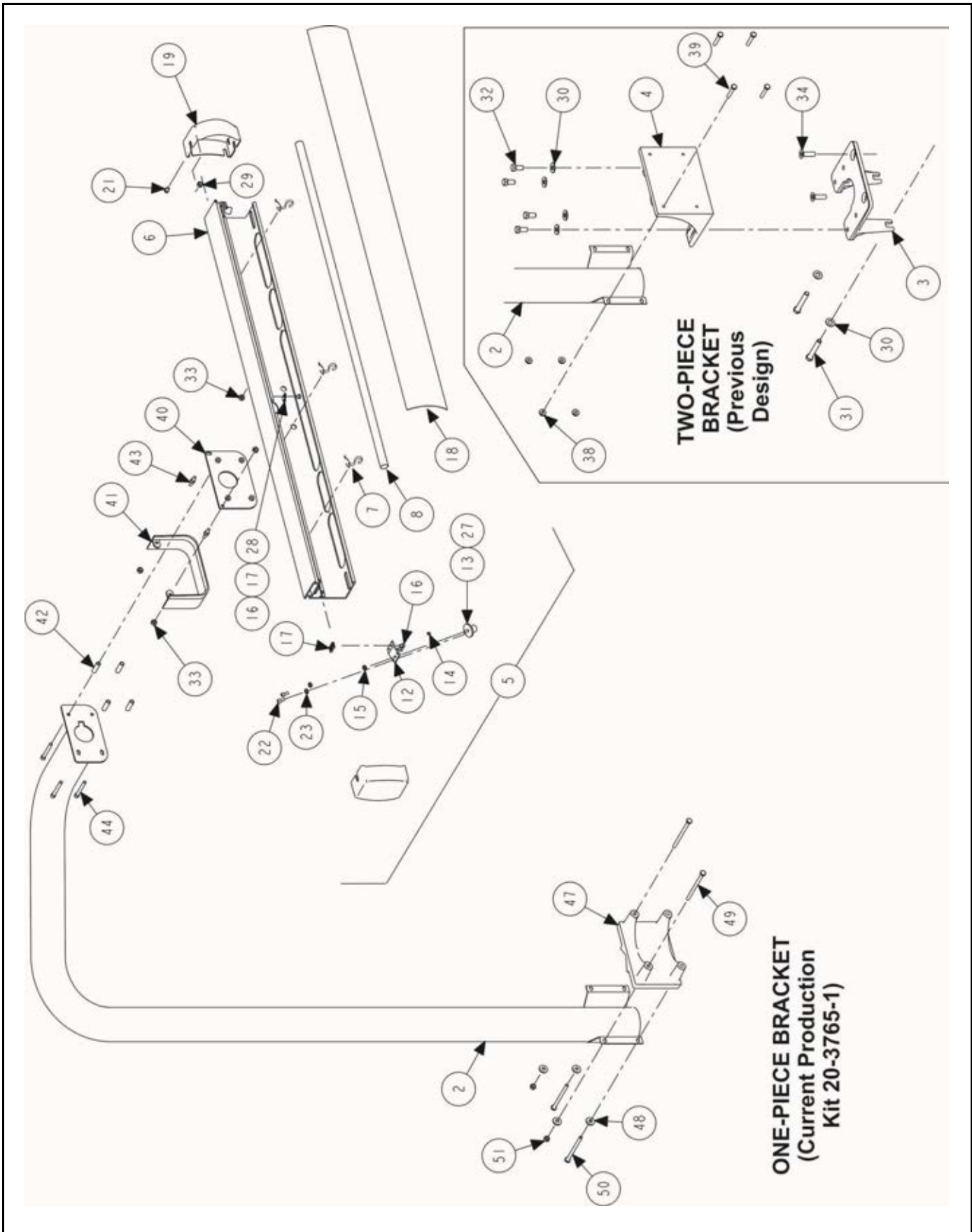

TOP DEAD CENTER LASER SYSTEM

REFER TO NEXT SHEET FOR PARTS DESCRIPTION LISTING

PARTS DESCRIPTION LISTING

TUBE AND LASER ASSEMBLY (COMMON TO ALL LED KITS)

Index No.	Part Number	Description	Qty.
2	16-912-1-005	TUBE ASSEMBLY, TDC LASER SUPPORT	1
5	105-787-1	HOUSING, TDC LASER HEADER ASSEMBLY LED (Consists Of:)	1
6	105-514-2	HOUSING, TDC LASER HEADER	1
7	35-212-2*	LAMP, LED, 12 VOLT, 36 INCH	1
8	117-230-2*	HANGER, LED STRIP	3
12	14-1130-2	BRACKET, TDC LASER MOUNT	2
13	105-530-1	HOUSING, TDC LASER ASSEMBLY	2
14	98-427-2	SPRING, TDC LASER ADJUSTMENT	2
15	76-61-2	NUT, KEPS 10-32	2
16	75-608-2	PAN HEAD MACHINE SCREW 10-32 X .31 INCH	5
17	76-382-2	NUT-T	5
18	190-192-2	SIGN, TDC LASER SYSTEM	1
19	69-1204-2	COVER, TDC LASER END CAP	2
20	Field Purchase	ADHESIVE, LOCTITE 242	A/R
21	75-535-2	LOW HEAD SOCKET CAP SCREW 1/4-20 X .38 INCH	2
22	75-161-2	PAN HEAD MACHINE SCREW 10-32 X .50 INCH	4
23	76-11-2	NUT, HEX 10-32	4
24	128-1155-2	DECAL, LASER COMPLIANCE 2M	1
25	128-1308-2	DECAL, RX CABLE WRAP, RIGHT (Not Illustrated)	1
26	128-1309-2	DECAL, RX CABLE WRAP, LEFT (Not Illustrated)	1
27	77-35-2	WASHER, FLAT 5/8 INCH	2
29	76-13-2	NUT, HEX 1/4-20	4
33	76-13-2	NUT, HEX 1/4-20	6
35	38-1206-2	CABLE, PC POWER SUPPLY ADAPTOR (Not Illustrated)	1
36	77-45-2	WASHER-FLAT 3/16 (Not Illustrated)	2
37	76-159-2	NUT, KEPS 3/8 - 16 (Not Illustrated)	4
40	51-2332-1-005	PLATE, TDC HAMMERHEAD MOUNT ASSEMBLY	1
41	69-1271-2	COVER, TDC ADJUSTMENT	1
42	98-443-2	SPRING, TDC LASER ADJUSTMENT	4
43	134-141-2	STUD, 1/4-20 DOUBLE ENDED, BRASS	2
44	75-877-3	SOCKET HEAD CAP SCREW 1/4-20 X 2.00 INCH NYLON	4
45	75-535-2	LOW HEAD SOCKET CAP SCREW 1/4-20 X .38 INCH (Not Illustrated)	2
46	37-693-1	WIRE ASM, GEN3 LED HAMMERHEAD (for retrofitting to a GEN 3) (Not Illus.)	1

* Use retrofit kit 20-3766-1 to replace obsoleted lamp with current light strip.

TWO PIECE MOUNT (OLDER VERSION)

Index	Part Number	Description	Qty.
3	11-1243-2	SUPPORT, TDC LASER BASE 9700	1
4	14-1129-2	BRACKET, TDC LASER BASE	1
30	77-65-2	WASHER, FLAT 3/8 INCH	6
31	74-16-2	HEX HEAD CAP SCREW 3/8-16 X 2.50 INCH (FULL-THREAD)	2
32	74-59-2	HEX HEAD CAP SCREW 3/8-16 X .75 INCH (FULL-THREAD)	4
34	74-461-2	BOLT, FLAT HEAD SOCKET CAP SCREW 3/8-16 X 1/4 INCH	2
38	76-367-2	NUT, FLANGE 1/4 - 20	4
39	75-703-2	HEX HEAD CAP SCREW 1/4-20 X 1.5 INCH GRADE 8	4

ONE PIECE MOUNT (NEWER VERSION FOUND IN KIT 20-3495-1)

Index	Part Number	Description	Qty.
47	14-1737-2	BRACKET, TDC LASER ONE PIECE	1
48	77-67-2	WASHER, FLAT 1/4 INCH	4
49	75-917-2	HEX HEAD CAP SCREW 1/4-20 X 4 INCH (FULL-THREAD) (GRADE 8)	2
50	75-918-2	HEX HEAD CAP SCREW 1/4-20 X 3.5 INCH (GRADE 8)	4
51	76-367-2	NUT, FLANGE 1/4 - 20	2

Lower TDC-mount holes in tub fitted with 76-414-2 (NUT - HEX INSERT 1/4-20 (Not Illustrated))



11250 HUNTER DRIVE BRIDGETON, MO 63044

PPP-Paint Code Required
A/R-As Required
REF-Reference