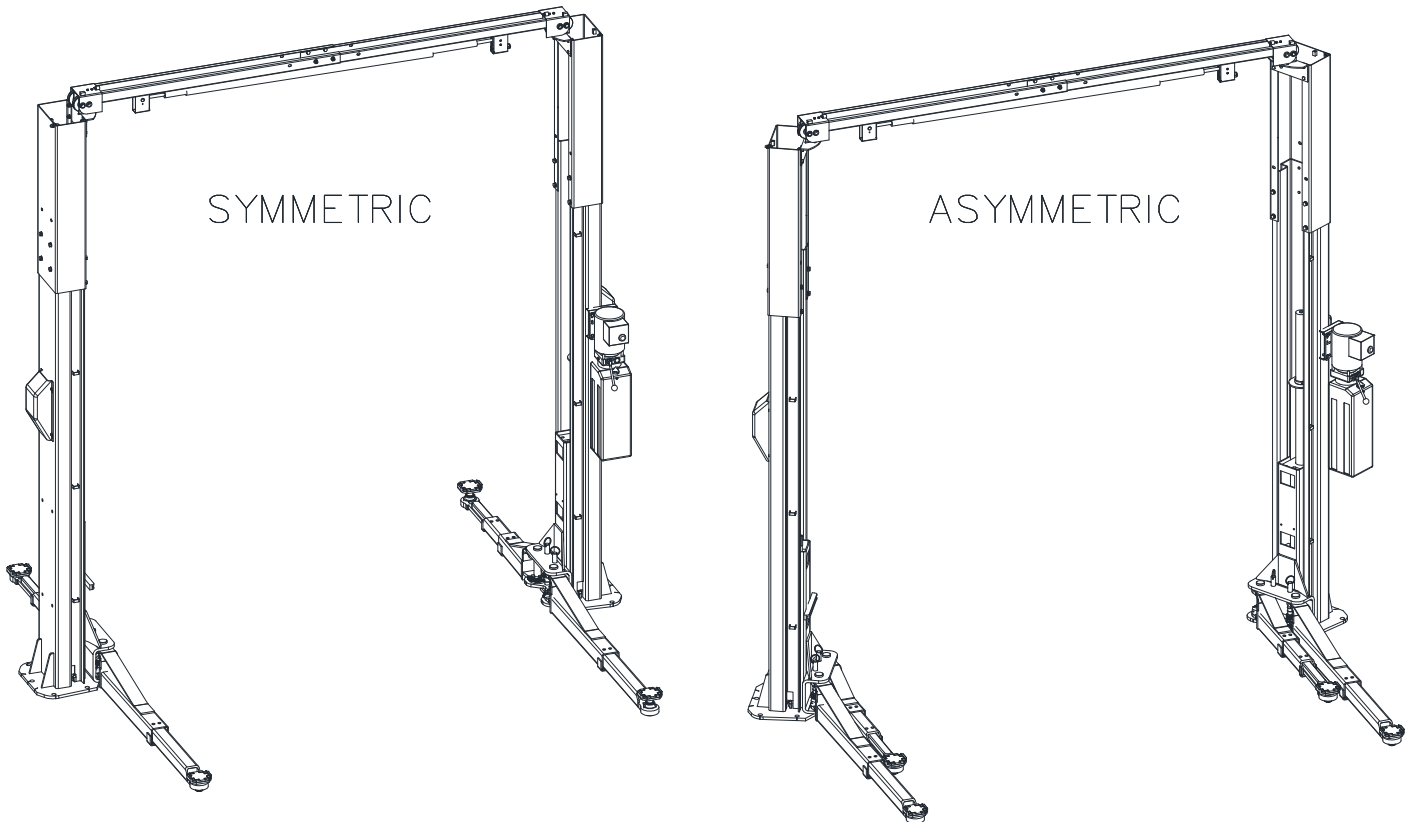


# **CL Challenger Lifts**

## **Installation, Operation & Maintenance Manual**

### **Two Post Surface Mounted Lift**



## **MODEL SA10**

(This lift may be installed either symmetrically or asymmetrically)

**10,000 LBS. CAPACITY** (2500 lbs. per Arm)

2311 South Park Rd. Louisville, Kentucky 40219

Email: [sales@challengerlifts.com](mailto:sales@challengerlifts.com) Web site: [www.challengerlifts.com](http://www.challengerlifts.com)

**Office 800-648-5438 / 502-625-0700 Fax 502-587-1933**

**IMPORTANT: READ THIS MANUAL COMPLETELY BEFORE  
INSTALLING or OPERATING LIFT**

## GENERAL SPECIFICATIONS

See Figure 1	SA10 (Symmetric Install)	SA10 (Asymmetric Install)
<b>A</b> Rise Height *	74 1/2" (1892mm)	
<b>B</b> Overall Height (Cylinder)	142 1/2" (3620mm)	
<b>C</b> Overhead Height (Adjustable)	136 1/2" / 142 1/2" (3467mm/3620mm)	
- with 2Ft Column Extension Kit	160 1/2" / 166 1/2" (4077mm/4230mm)	
<b>D</b> Base Width (Adjustable) **	129" / 135" (3277mm/3429mm)	131 1/2" / 137 1/2" (3340mm/3493mm)
<b>E</b> Drive-Thru Clearance	92 3/4" / 98 3/4" (2356mm/2508mm)	88 1/2" / 94 1/2" (2248mm/2400mm)
<b>F</b> Floor to Overhead Switch	131 1/8" / 137 1/8" (3331mm/3483mm)	
<b>G</b> Short Arm Reach	22 3/8" / 41 1/2" (568mm-1055mm)	
<b>H</b> Long Arm Reach	38 1/4" / 59" (970mm-1500mm)	
<b>K</b> Screw Pad Height	4 3/4" – 6 7/8" (119mm-174mm)	
<b>L</b> Inside of Columns	106 3/4" / 112 3/4" (2710mm/2862mm)	101 1/2" / 107 1/2" (2579mm/2731mm)
<b>P</b> To Front Obstruction	12'	10'
<b>Q</b> To Rear Obstruction	12'	14'
Arm Reach Front/Rear (Min.-Max.)	Front (22.4"-41.5") / Rear (38.3"-58.9")	
Lifting Capacity *** (Hydraulic Pressure at Cap.)	10,000 lbs. (2500 lbs. per arm) (2850 psi)	
Ceiling Height Required	144" (3658mm)	
Motor	2HP, Single Phase, 60Hz	
Voltage	208-230	
Rise Time ****	44 seconds	

\* Rise Height measured with footpads in the highest position.

\*\* Overall width of Asymmetric Lift is 135"/141" including Power Unit. Use Dimension "D" for installation purposes.

\*\*\* Lift capacity ratings are based on loads equally distributed on all four arms.

\*\*\*\* Lifting and lowering speeds may vary depending on the weight of the vehicle.

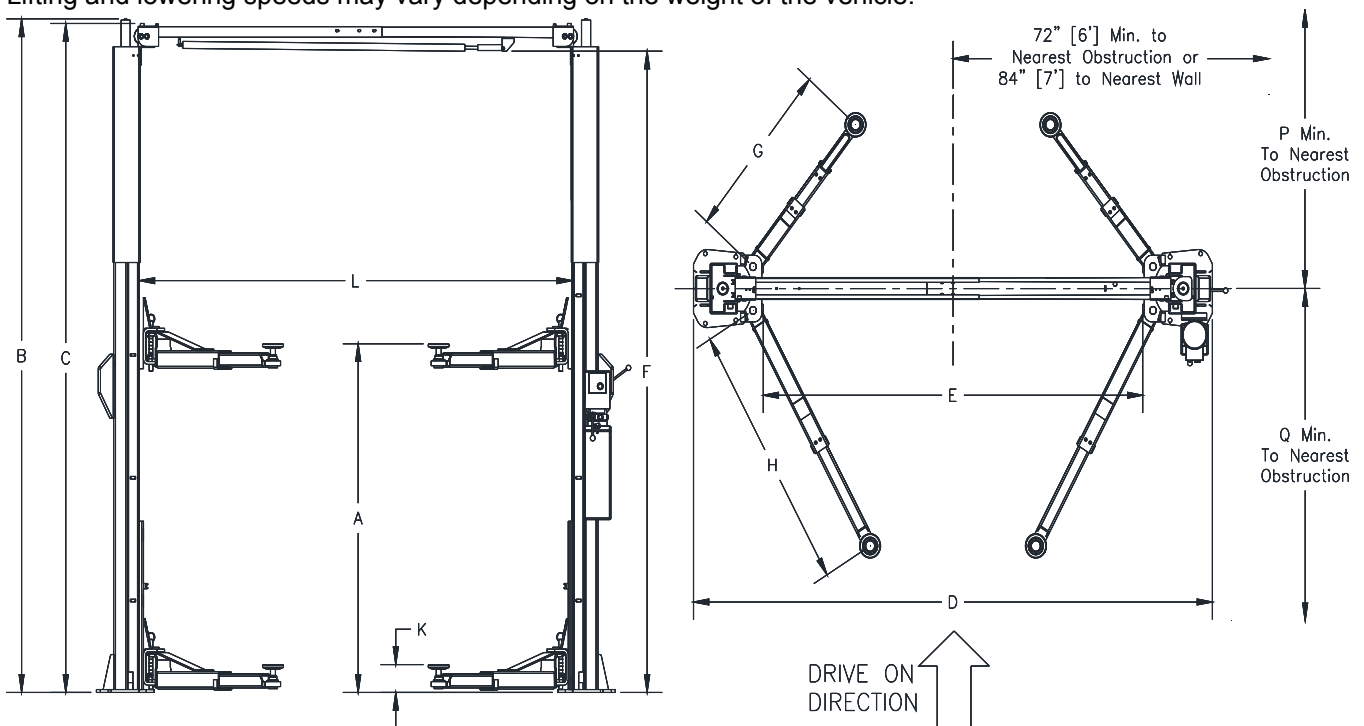


Fig 1 - General Specifications / Service Bay Layout

## VERTICAL CLEARANCE

Check the height of the area where the lift is to be installed. Clearance should be calculated based on the full raised height of the lift.



**Failure by purchaser to provide adequate clearance could result in unsatisfactory lift performance, property damage, or personal injury.**

## FLOORING

Be certain you have the proper concrete floor to properly handle the loaded lift. Floor should be in generally good condition with no large cracks, spalling or deterioration.

**Minimum requirements for concrete are 4 inches minimum depth, with steel reinforcement, 3500 psi, cured for 28 days per local commercial practice.** Floor should be level within 3/8 inch over the installation area. No anchors should be installed within 8 inches of any crack, edge, or expansion joint. If these conditions cannot be met, a pad may be poured to accommodate the lift.

Check with local building inspectors and/or permits office for any special instructions or approvals required for your installation.

A qualified person should be consulted to address seismic loads and other local or state requirements.



**Failure by purchaser to provide the recommended mounting surface could result in unsatisfactory lift performance, property damage, or personal injury.**

## LOCATION

This lift has been evaluated for indoor use only with an operating ambient temp. range of 5 – 40°C (41–104°F)

## ELECTRICAL REQUIREMENTS

For lift installation and operation it is necessary to have a dedicated circuit with circuit breaker or time delay fuse. Refer to wiring diagram for circuit sizing.

## SAFETY NOTICES AND DECALS

For your safety, and the safety of others, read and understand all of the safety notices and decals included here.

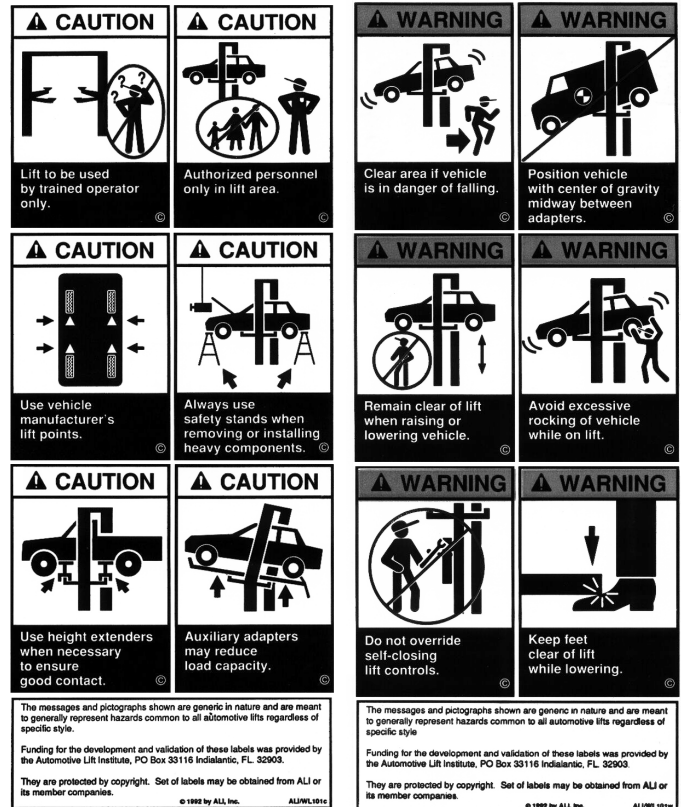
**READ ENTIRE MANUAL BEFORE ASSEMBLING, INSTALLING, OPERATING, OR SERVICING THIS EQUIPMENT.**

**PROPER MAINTENANCE AND INSPECTION IS NECESSARY FOR SAFE OPERATION.  
DO NOT OPERATE A DAMAGED LIFT.**

Safety decals similar to those shown here are found on a properly installed lift. Be sure that all safety decals have been correctly installed on the columns as described in this installation manual. Verify that all authorized operators know the location of these decals and fully understand their meaning. Replace worn, faded, or damaged decals promptly.



**Do not attempt to raise a vehicle on the lift until the lift has been correctly installed and adjusted as described in this manual.**



## RECEIVING

The shipment should be thoroughly inspected as soon as it is received. The signed bill of lading is acknowledgement by the carrier of receipt in good condition of shipment covered by our invoice.

If any of the goods called for on this bill of lading are shorted or damaged, do not accept them until the carrier makes a notation on the freight bill of the shorted or damaged goods. Do this for your own protection.

NOTIFY **Challenger Lifts** AT ONCE if any hidden loss or damage is discovered after receipt.

IT IS DIFFICULT TO COLLECT FOR LOSS OR DAMAGE AFTER YOU HAVE GIVEN THE CARRIER A CLEAR RECEIPT.

File your claim with **Challenger Lifts** promptly. Support your claim with copies of the bill of lading, freight bill, and photographs, if available.

### Component Packing List

PART #	QTY/ LIFT	DESCRIPTION
3W-01P	1	Power Column Weld
3W-01I	1	Idler Column Weld
3W-03PA	1	Power Overhead Ass'y
3W-03IA	1	Idler Overhead Ass'y
AB-9367	1	Power Unit
SA10-HW-A	1	Hardware Box
3W-01-05PA	1	Power Column Extension
3W-01-05IA	1	Idler Column Extension
3W-04-01A	2	Rear Arm Assembly
3W-04-19A	2	Front Arm Assembly
B2270	4	Foot Pad Assembly
3W-06-08A	2	Synchronizer Cable Ass'y
3W-06-06A	1	Power Hose
3W-06-07A	1	Idler Hose
3W-06-05A	1	Extension Hose
3W-01-11-01	1	Power Lock Cover
3W-01-11-02	1	Idler Lock Cover
3W-03-13A/15A	1	Shutoff Bar/Foam Cover
3W-03-07	2	Overhead Bracket
SA10-LHW	1	Internal Hardware Box

## INSTALLATION

### SAFETY REQUIREMENTS FOR INSTALLATION AND SERVICE

Refer to ANSI/ALI ALIS (current edition)

**IMPORTANT:** Always wear safety glasses while installing lift.

### TOOLS (MINIMUM REQUIRED)

- a. Tape measure, 16ft
- b. Chalk line
- c. 4ft level
- d. Carpenters Square
- e. 10" adjustable wrench
- f. Open end wrenches 14mm,16mm,17mm,19mm
- g. Needle Nose pliers
- h. Snap Ring pliers
- i. Screw Drivers (Flat and Phillips)
- j. Hammer drill w/ 3/4" diameter carbide-tipped bits
- k. 2lb hammer
- l. Torque wrench: 150 ft.-lbs. min. & 1 1/8" socket
- m. 12 ft. Step ladder
- n. Anti-Seize lubricant (arm pins, foot pad screw threads, and foot pad stop rings)

### LAYOUT

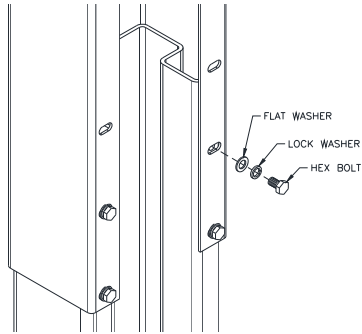
- 1) Layout the service bay according to architect's plans or owners instructions (**see Fig 1**). **Failure to install in this orientation can result in personal and property damage.** Be certain that the proper conditions exist, see page 3.

### DISASSEMBLY

- 2) Place a 4x4 piece of lumber 2' from each end of the packaged lift. Remove Column Extensions, Arms, and Hardware Box. Remove steel end brackets bolted to Columns. Remove remaining packaging and any loose items placed inside the columns.

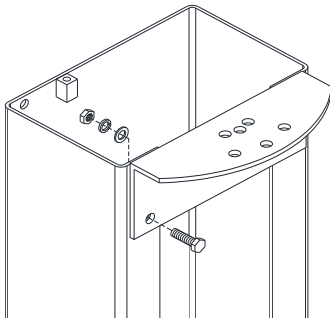
### COLUMNS

- 3) With columns still horizontal, assemble Power Column Extension to Power Column using (8 sets) M12 x 20 Hex bolts, flat washers, and lock washers. The (2) Column Extensions are not identical. **IMPORTANT: The Lock Release Guide Block at top of Column Extension should be in-line with Lock Release Pulley in Column. See Fig 10 for Clarification.** For the tall height setting, use bottom holes as shown in **Fig 2**. For the short setting, use the upper holes. Repeat for opposite Idler Column and Idler Column Extension.



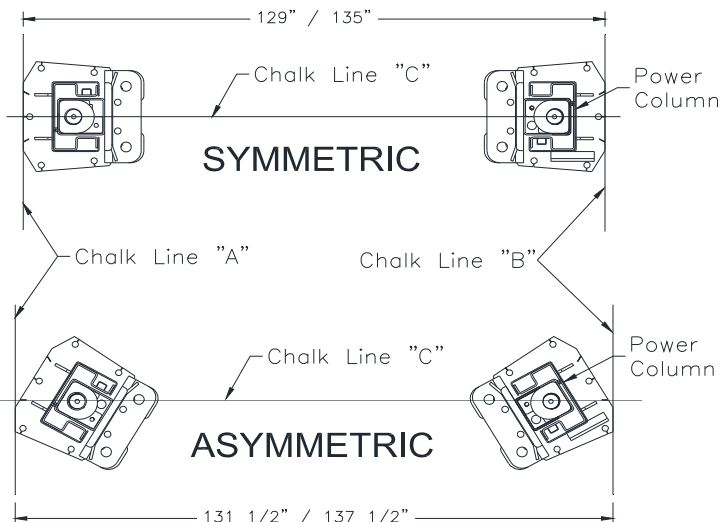
**Fig 2 - Column Extension**

- 4) Assemble Overhead Mounting Bracket to the Column Extension using (4 sets) M12 x 25 Hex bolts, flat washers, lock washers, and nuts. Repeat for opposite bracket and extension. See Fig 3 below.



**Fig 3 - Column Extension**

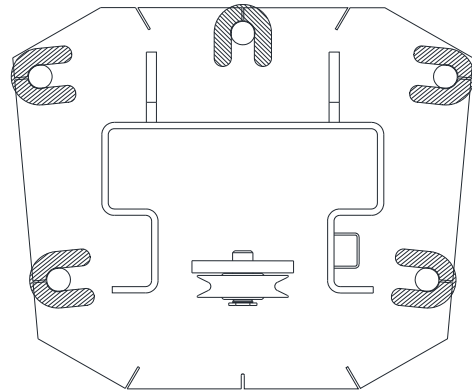
- 5) Slide both Carriages into the first lock position while Columns are horizontal. Ensure both locks are engaged.
- 6) Refer to Fig 1. Using the Base Width (D) Dimension, chalk two parallel lines (A & B) on the floor within 1/8" tolerance. Chalk a third line (C) perpendicular to lines A & B to designate fore and aft location. Erect both Column assemblies. Align the base plate edges to the chalk lines as seen in Fig 4 below. Slots in front and back of base plate should be in-line with chalk line "C".



**Fig 4 - Layout**

### ANCHORING

- 7) The anchor bolts must be installed at least 8" from any crack, edge, or expansion joint.
- 8) Use a concrete hammer drill with a 3/4 inch carbide bit. Tip diameter should conform to ANSI Standard B94.12-1977 (.775 to .787). Do not use excessively worn bits or bits which have been incorrectly sharpened. A core bit may be necessary if an obstruction is encountered. **Never substitute with shorter anchor.**
- 9) Recheck "Base Width" dimension, Fig 1. Drill the anchor holes (Power Column Only) using the base plate as a template. Drill through the floor if possible or to a depth of 5 inches minimum.
- 10) Vacuum dust from the hole for proper holding power.
- 11) Shim column to plumb using the shims provided as shown in Fig 5. DO NOT shim more than 1/2" at any given point. Use a level no less than 24" in length to plumb Columns.
- 12) Assemble washer and nut to anchor with nut just below impact section of bolt. Drive anchor into hole until nut and washer contact base.

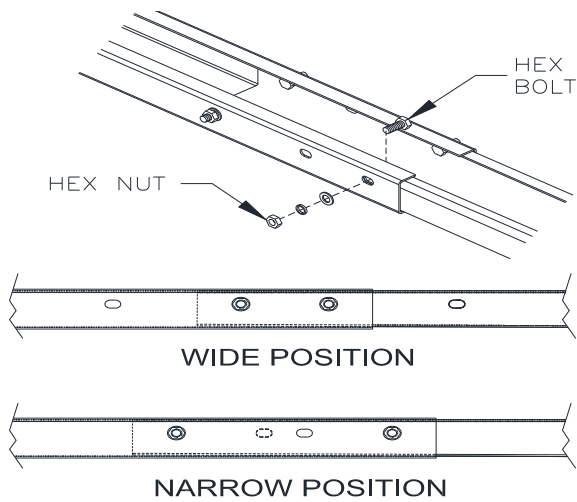


**Fig 5 - Column Shimming**

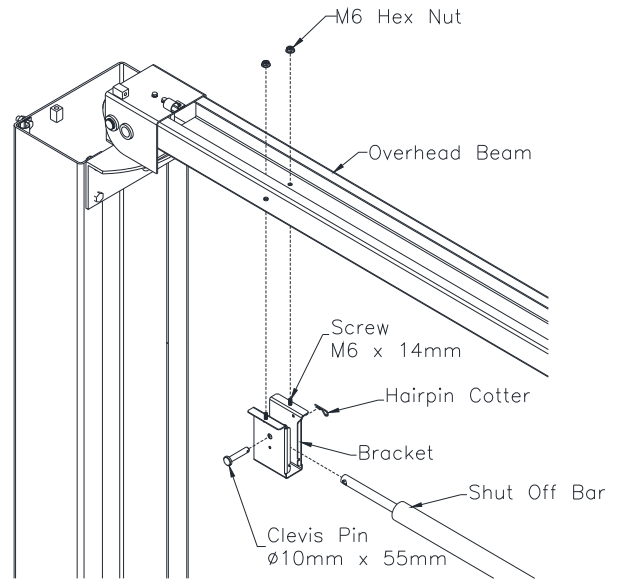
- 13) Tighten Power Column anchors and recheck Column for plumb. Re-shim if necessary. Torque to **150 foot-pounds** to set anchors.

### OVERHEAD

- 14) Assemble two Overhead pieces using (6 sets) M10 x 20 bolt, nut, flat washer, and lock washer as shown in Fig 6. Hand-tighten bolts to allow adjustment if needed. Use Base Width (D) Dimension to determine proper holes to use.

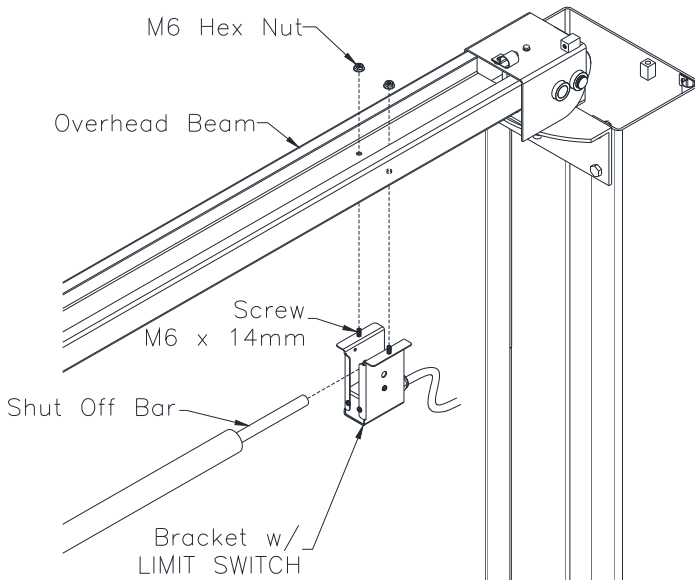


**Fig 6 – Overhead**



**Fig. 7b – Overhead Limit Switch Idler Side**

15) Install Overhead Limit Switch to the Overhead Beam on the Power Side of the lift. See **Fig 7a**.



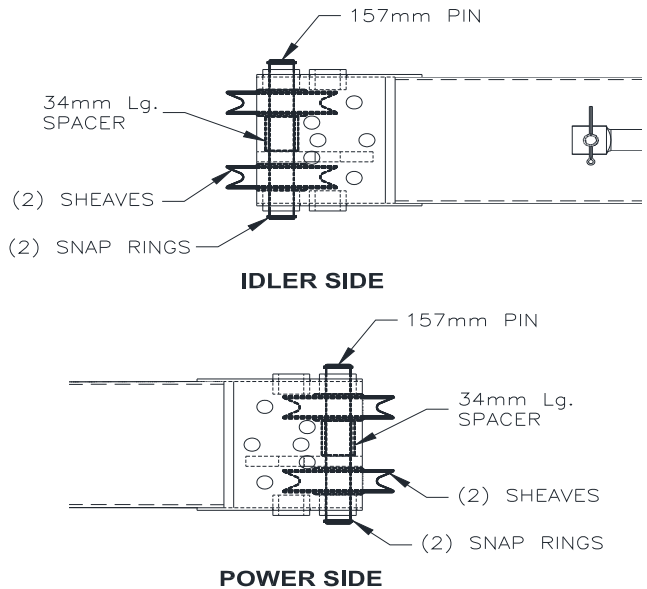
**Fig 7a – Overhead Limit Switch Power Side**

16) Install the Idler Bracket to the Overhead Beam on the Idler Side of the lift. See **Fig 7b**. **Note the orientation of the Idler Bracket. The narrow slot needs to be facing towards the Power Column.** Slide the Shutoff bar over the limit switch on the Power Side. Pin the Shutoff Bar to the Idler Side Bracket with the 10mm dia. x 55mm Lg. clevis pin & hairpin cotter.

**SYMMETRIC**

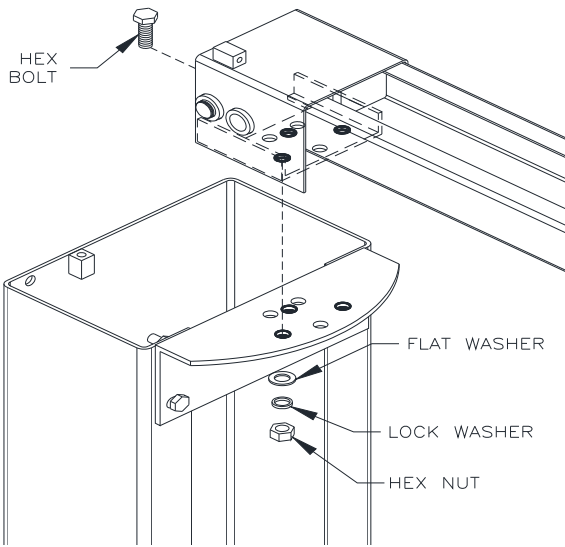
17) For Asymmetric installation, skip to Step 19.

18) With the Overhead positioned **UPSIDE DOWN**, assemble the cable sheaves, spacers, and pins as shown in **Fig 8** below.



**Fig 8 – Symmetric Sheave Assembly**

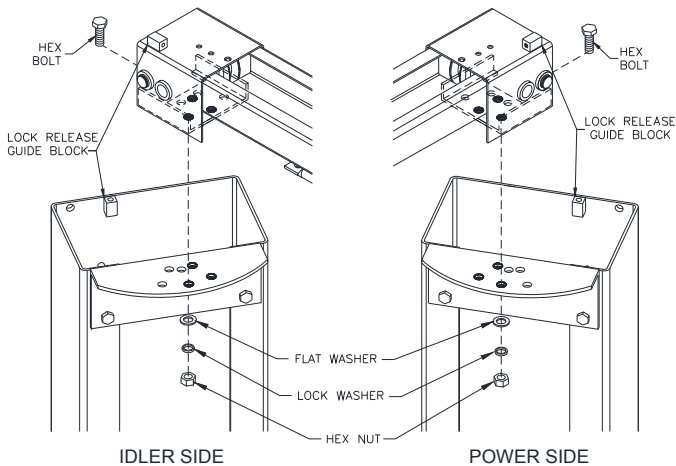
19) Place the Overhead on top of the mounting brackets on Column Extensions and bolt together using (3 sets) M12 x 25 Hex bolt, nut, flat washer, and lock washer. Hand-tighten bolts to allow for column adjustment if needed. Use the holes highlighted below in **Fig 9** below.



**Fig 9 – Symmetric Overhead Mounting**

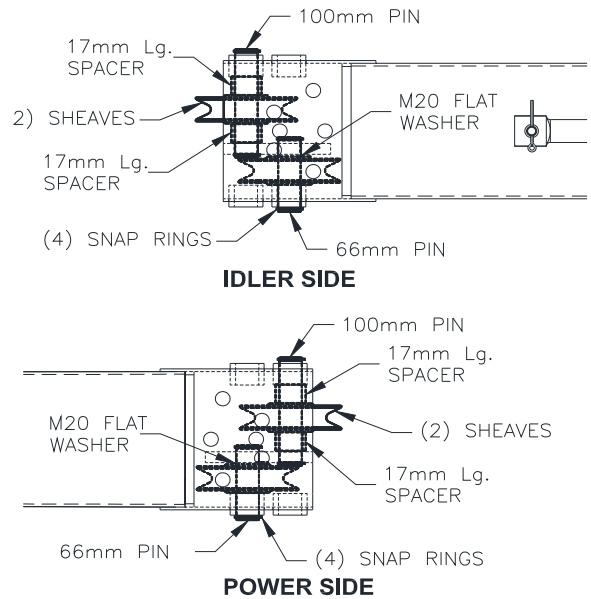
**ASYMMETRIC**

20) Place the Overhead on top of the mounting brackets on Column Extensions and bolt together using (3 sets) M12 x 25 Hex bolt, nut, flat washer, and lock washer. Hand-tighten bolts to allow for column adjustment if needed. Use the holes highlighted in **Fig 10** below.



**Fig 10 – Asymmetric Overhead Mounting**

21) Disassemble sheave assemblies from each end. Assemble the cable sheaves, spacers, and pins as shown in **Fig 11** below as if viewing from underneath the lift. A flat washer should be placed between sheave and offset plate. **Note: The Sheave in the narrow section of the Power Side Overhead Beam should be installed after routing the sync cables.**



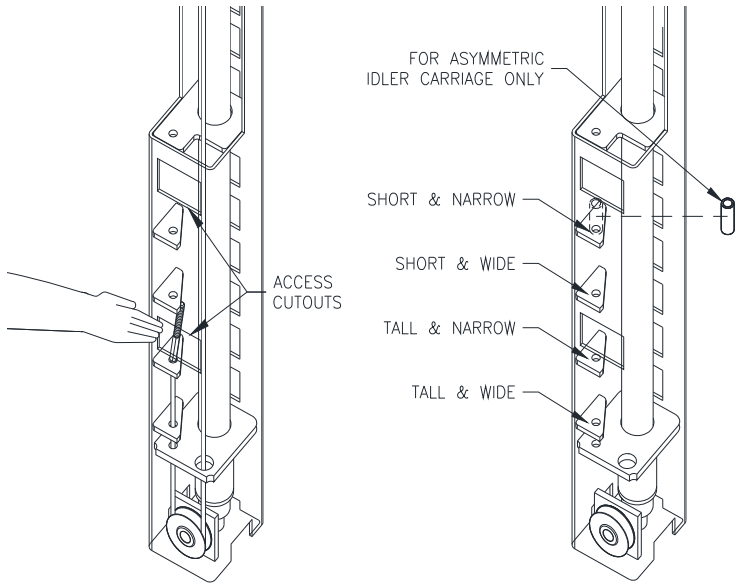
**Fig 11 – Asymmetric Sheave Assembly**

**ANCHORING CONT.**

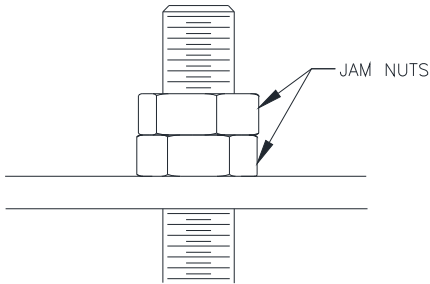
- 22) Check Idler Column shimming. Use additional shims (see **Fig 5**) to remove any gaps that may have been created while installing Overhead. Repeat steps 7-13 for the Idler Column anchoring.
- 23) Tighten all bolts in Overhead after both Columns are secured to the floor.

**SYNCHRONIZER CABLES**

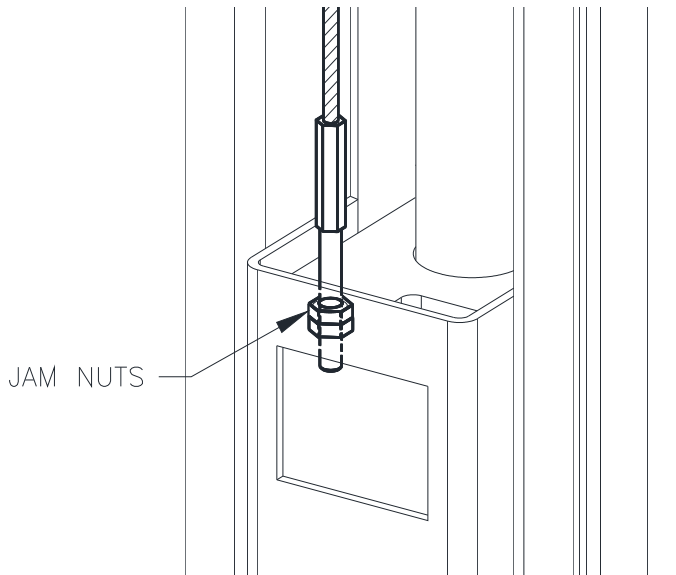
- 24) Carriages should be setting in first lock position as mentioned in an earlier step.
- 25) Each cable is pre-routed around base sheave and up through the bottom of the Carriage. Attach that end of the Synchronizing Cable to the proper carriage tab according to **Fig 12a**. For Asymmetrical lift, use 85mm lg. spacer in Idler Carriage above appropriate tab.
- 26) Secure the cables with the jam nuts provided as shown in **Fig 12b**.
- 27) Route other end of cable up and over sheave in Overhead. Follow across to sheave on opposite Column. Route cable down through Column to top mounting plate in Carriage. Attach cable to Carriage top plate as seen in **Fig 12c** with (2) hex jam nuts. Repeat for opposite side.
- 28) Adjust nuts on cable fitting inside carriage up or down to allow only enough room to get a nut started on the opposite end of the cable to allow adequate thread length to tighten cables.



**Fig 12a – Cable Attachment Points**

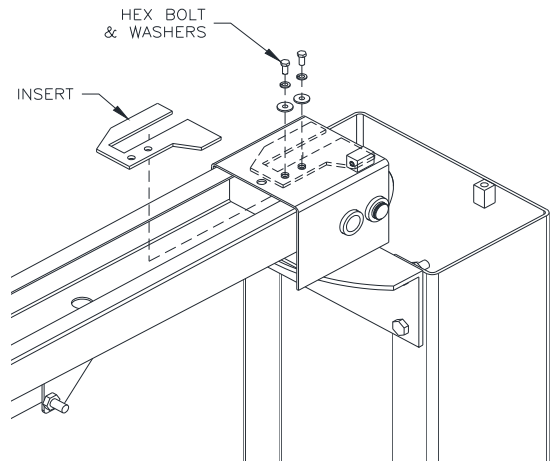


**Fig 12b – Jam Nuts**



**Fig 12c - Carriage Connection**

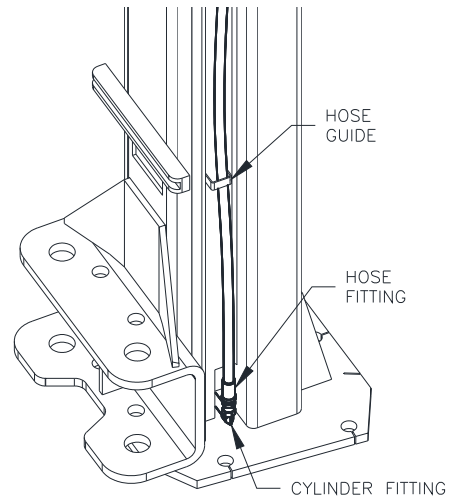
washer, and lock washer as shown in Fig 13. Repeat for both sides.



**Fig 13 – Cable Trapping**

**HYDRAULIC HOSES**

30) Attach Power Hose to Cylinder Fitting at the bottom of the Power Column as shown in Fig 14 below. Repeat with longer Idler Hose and Idler Column. If lift is installed in the “Tall Height” setting, use Hose Extension and Hose Extension Fitting between Idler Hose and Cylinder Fitting.



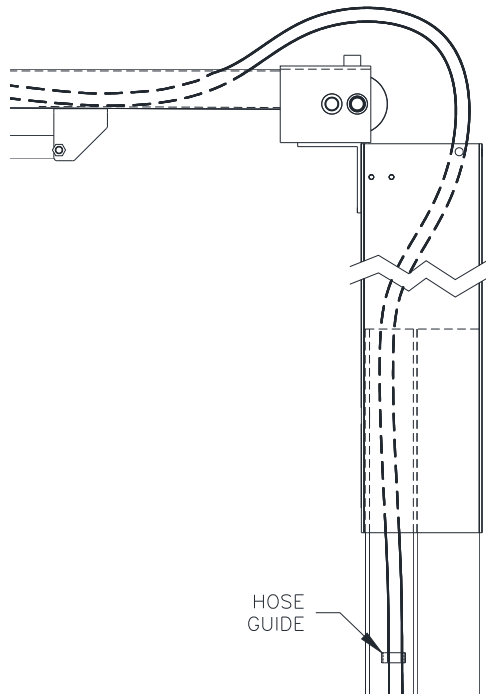
**Fig 14 – Bottom Hose Connection**

31) Route hoses through hose guides in Column. Run Idler hose up through Column Extension, over the top of the Overhead, and down through the opposite Column Extension as shown in Fig 15 below.

**CABLE TRAPPING**

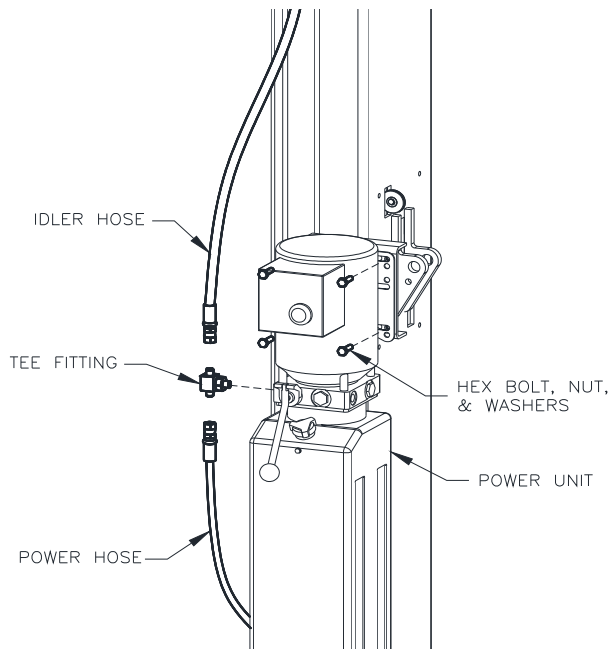
29) Place Cable Trap Plate inside Overhead and slide into end of Overhead. Bolt plate to Overhead end using (2 Sets) M6 bolt, flat





**Fig 15 – Hose Routing**

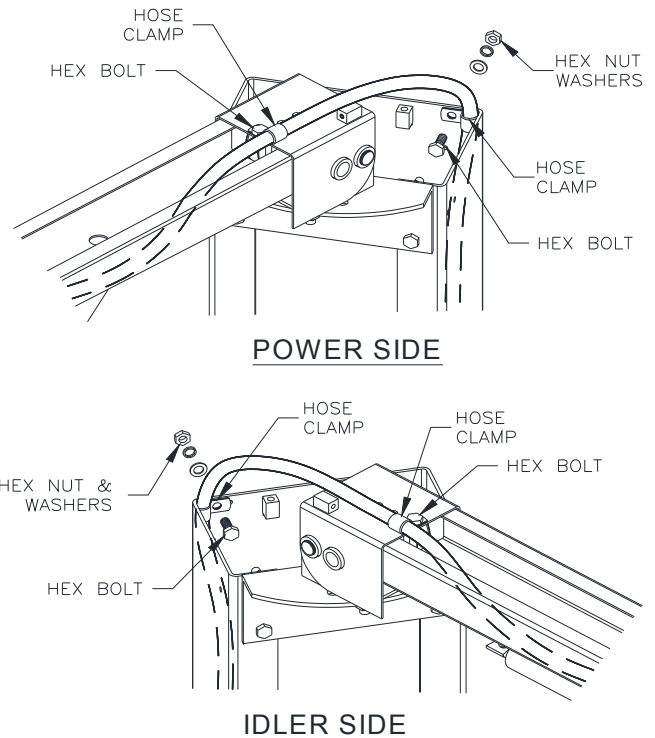
- 32) Remove the Plug from the left side and relocate it to the right side. Assemble Power Unit, Tee Fitting, and hoses together as shown in **Fig 16**. Use (4 sets) M8 bolt, nut, flat washer, and lock washer to attach Power Unit to column bracket.



**Fig 16 – Power Unit Assembly**

- 33) Clamp the Idler Hose to the Overhead and Column Extensions using a (1 set) hose clamp, M10 x 25 hex bolt, nut, flat washer, and lock washer as shown in **Fig 17** below. For both the Symmetric and Asymmetric configuration, the hose clamp in the Column Extension should be

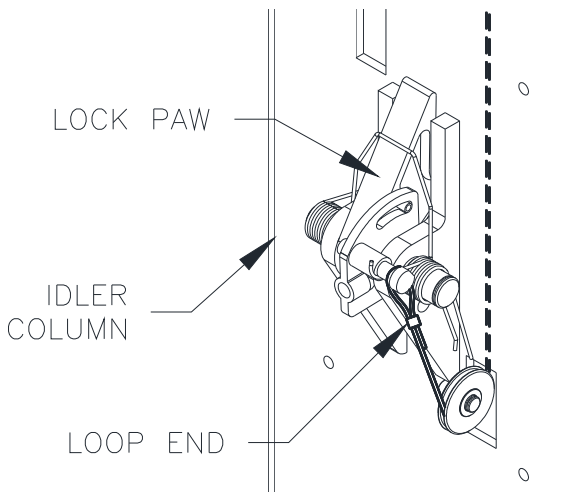
on the same side as the hose guides welded on the Columns. **IMPORTANT: ENSURE HOSE DOES NOT CONTACT CYLINDERS WHEN LIFT IS FULLY RAISED.**



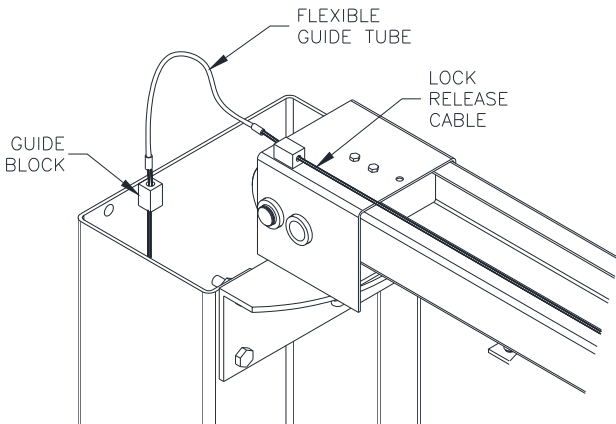
**Fig 17 – Hydraulic Hose Routing**

**LOCK RELEASE**

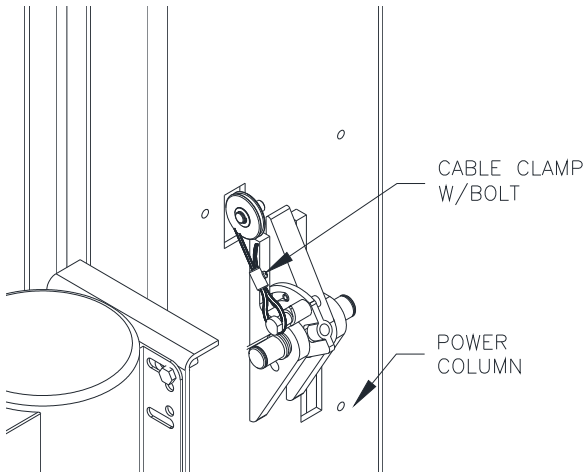
- 34) While the carriages are still sitting in the locks from the previous steps, route the Lock Release Cable assembly (Loop End) through the Idler Column opening, around the pulley and attach to the Lock Release Cam as seen in **Fig 18a**.
- 35) Continue routing the cable up the inside of the Idler Column and through guide block at top of Column Extension. Then route cable through Flexible Guide Tube and guide block on top of Overhead. Insert ends of Flexible Guide Tube into guide blocks. See **Fig 18b**. Reverse this step for the Power side. **IMPORTANT: ENSURE FLEXIBLE GUIDE TUBE DOES NOT CONTACT CYLINDERS WHEN LIFT IS FULLY RAISED.**
- 36) Continue routing the cable down the inside of the Power Column and out through the column opening and around the Upper Pulley as seen in **Fig 18c**. Insert the Lock Release Cable through the Cable Clamp Tube and loop the remaining cable around the pin of the Lock Release Cam and back thru the clamp. Remove all slack in the cable until cam on Idler side is rotated as shown in **Fig. 18a** and tighten the clamp bolt.



**Fig 18a – Lock Release (Idler Side)**

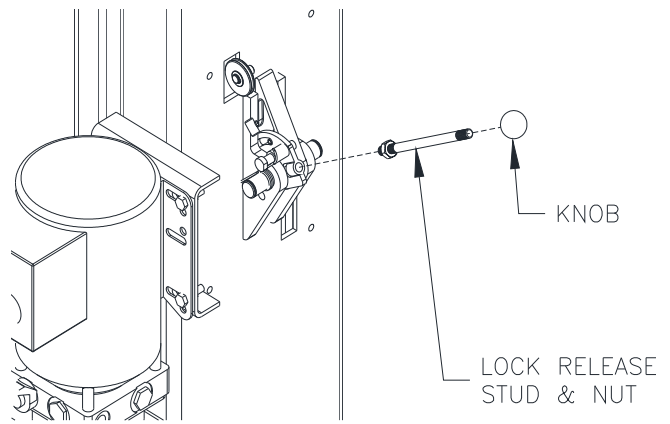


**Fig 18b – Lock Release (Idler Side)**



**Fig 18c – Lock Release (Power Side)**

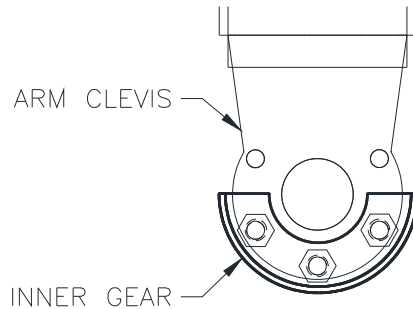
37) Attach Lock Release Stud and M10 Hex Jam Nut to Lock Release Cam. See Fig 19.



**Fig 19– Lock Release Cover**

**SYMMETRIC ARM INSTALLATION**

38) For Asymmetric installation, skip to step 39. Ensure the Inner Gear is positioned on the arms as shown in Fig 20. Lubricate the Arm Pin or carriage arm pin hole with “anti-seize” and install the arms. Place snap ring in groove on bottom of arm pin. Ensure that the arm restraint gears engage and disengage properly. Arm restraint gears should disengage completely when lift is fully lowered. When gears are engaged, Outer Gear should lower enough for top of teeth to be level with top of Inner Gear teeth. If any binding occurs, adjust Inner Gear as necessary.

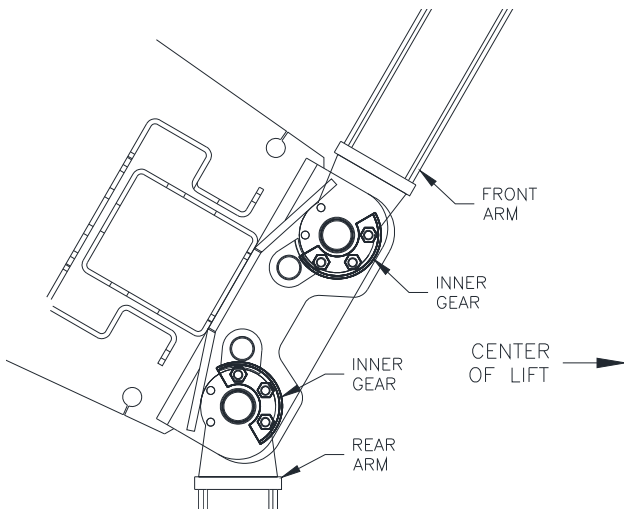


**Fig 20 – Symmetric Inner Gear**

39) Make sure all the arm bolts are tight. Slide all the arms out so they are fully extended making sure that the male is retained in the female.

**ASYMMETRIC ARM INSTALLATION**

40) With arms spread open, Inner Gear should be rotated to face center of lift for all (4) arms as shown in Fig 21. Lubricate the Arm Pin or carriage arm pin hole with “anti-seize” and install the arms. Place snap ring in groove on bottom of Arm Pin. Ensure that the arm restraint gears engage and disengage properly. Arm restraint gears should disengage completely when lift is fully lowered. When gears are engaged, Outer Gear should lower enough for top of teeth to be level with top of Inner Gear teeth. If any binding occurs, adjust Inner Gear as necessary.



**Fig 21 – Asymmetric Inner Gear**

- 41) Make sure all the arm bolts are tight. Slide all the arms out so they are fully extended making sure that the male is retained in the female.

#### **FOOT PADS**

- 42) Extend the Foot Pad to both extents and apply “anti-seize” to the three retaining rings and where the double screw makes contact with the base of the Foot Pad.

**BE CERTAIN ALL FITTINGS AND CONNECTIONS ARE TIGHT. IT IS THE INSTALLERS RESPONSIBILITY TO INSURE THE SYSTEM IS LEAK-FREE.** Fill the Power Unit with three gallons of clean 10wt anti-foam, anti-rust hydraulic oil or Dexron III ATF. **DO NOT USE OILS WITH DETERGENTS.**

#### **ELECTRICAL**

- 43) Refer to **Fig 22 Wiring Diagram** for all steps under this heading.

##### **Single Phase**

- 44) After routing Overhead Limit Switch wires through hole in Overhead and along the hydraulic line to the power unit, connect the Overhead Limit Switch Cord to Power Unit as shown.
- 45) Connect Power Unit to suitable electrical source as shown.

##### **Three Phase**

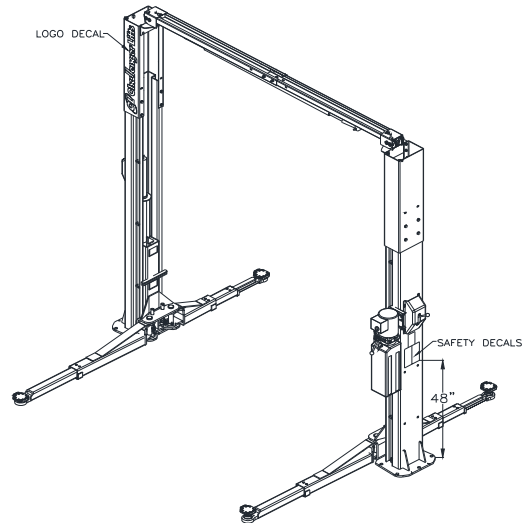
- 46) Power unit is factory wired for 240 volt. Refer to wiring diagram or motor plate for optional voltages.
- 47) Connect Contactor Enclosure to column. Mounting hardware should be centered on the column side to side to avoid the path of the slide blocks.
- 48) Connect Overhead Limit Switch Cord to Contactor as shown.

- 49) Connect Contactor to Power unit as shown. Connect Contactor to suitable electrical source as shown.

**IMPORTANT:** AFTER WIRING HAS BEEN COMPLETED, TEST OPERATION OF POWER UNIT & OVERHEAD LIMIT SWITCH. WHILE RAISING LIFT, OPERATE OVERHEAD SHUTOFF BAR. POWER UNIT MOTOR SHOULD STOP WHEN SHUTOFF BAR IS RAISED.

#### **COLUMN DECAL PLACEMENT**

- 50) Clean the surface of the columns before placing the decals.
- 51) Apply the Safety Decals (Pg. 3) 48” above the base plate on the power column and center the Logo Decal on the idler column extension..



**Fig 23 – Safety & Logo Decal Placement**

#### **FINAL ADJUSTMENTS**

##### **HYDRAULICS**

- 52) Lower the lift to the floor and raise the lift approximately one foot.
- 53) Start with Idler side first. Slowly and carefully loosen the bleed plug on top of the cylinder just enough to allow the entrapped air to escape. Tighten plug if fluid starts leaking out. Repeat for power side.
- 54) If lift lowers completely before all of the air has escaped, raise lift 6 inches. Repeat step 52 until no air comes out of cylinder.
- 55) Pressure test hydraulic system. Energize power unit, raise lift to full rise and continue to run motor for additional 10 seconds. (NOTE: pressure relief will make a high pitch squeal sound for these 10 seconds.) Check hydraulic system for leaks.

- 56) Energize power unit again for 10 seconds. With a clean rag, wipe down both cylinder rods. (The cylinders are shipped with a small amount of clear anti-corrosive lubricant that will be forced out through the wiper when the lift reaches full rise.) If lubricant is not wiped clean from the cylinder rod, the cylinder may appear to be leaking.

#### **SYNCHRONIZING CABLES**

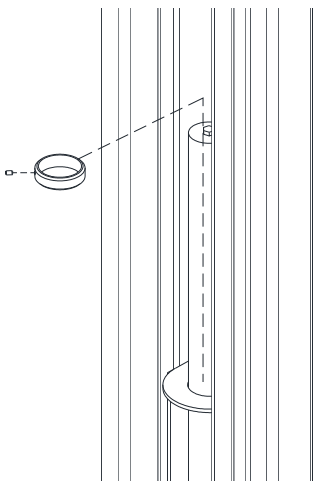
- 57) Raise lift and insure carriages lower into same lock position.
- 58) Adjust synchronizing cables so the tension is equal in both cables and carriages are firmly sitting on locks.
- 59) Cycle lift to insure that latches engage simultaneously.

#### **LOCK RELEASE CABLE**

- 60) Raise lift to a lock position but don't set into the lock. Pull and release Power Column lock release handle while watching Idler Column lock. Adjust Cable tension by removing slack and retightening cable clamp at the power side. Both locks should engage and disengage simultaneously.
- 61) Install Lock Release Covers onto back of Columns. Lever Knob will need to be removed and re-installed to install Power Lock Cover.

#### **CYLINDER**

- 62) Install Cylinder Clamp Ring to each cylinder as shown in **Fig. 24** using M6 set screw.



**Fig. 24 – Cylinder Clamp Ring**

#### **COLUMNS**

- 63) Apply heavy viscous grease to (4) inner corners or Column where the slide blocks travel. Raise and lower the lift as required to get access to entire length of slide tracks.

#### **FINAL CHECKOUT PROCEDURE**

- 64) Demonstrate the operation of the lift to the owner/operator/employer using a typical vehicle and review correct and safe lifting procedures using the **Lifting It Right** booklet as a guide.
- 65) Return all provided literature (including this manual) to the literature pack envelope and deliver the envelope to the owner/operator/employer.
- 66) Complete the online warranty registration (refer to the included warranty statement).

# Wiring Diagram

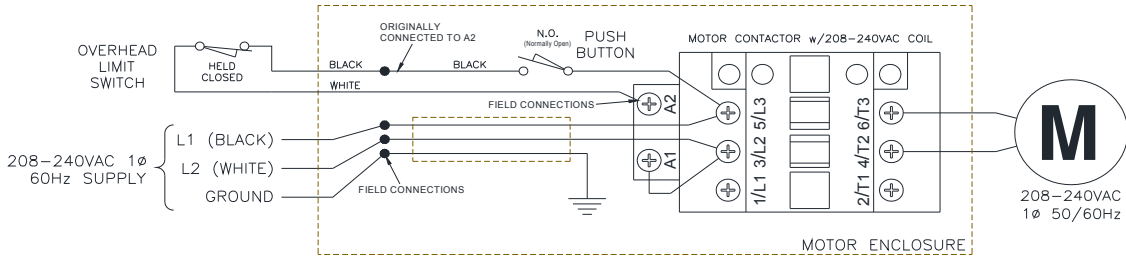
\* EACH LIFT SHOULD HAVE A DEDICATED CIRCUIT WITH A DOUBLE POLE (THREE POLE FOR 3 PHASE) BREAKER OR TIME DELAY FUSE SIZED ACCORDING TO THE FOLLOWING CHART.

	1 $\phi$ 208-240V	3 $\phi$ 208V	3 $\phi$ 220-240V	3 $\phi$ 440-480V
2Hp	30amp	15amp	15amp	5amp

\* WIRING MUST COMPLY WITH ALL LOCAL ELECTRICAL CODES.

\* ELECTRICAL CODE REQUIRES A SERVICE DISCONNECT FOR THIS DEVICE. WE SUGGEST THIS SERVICE DISCONNECT BE LOCATED NEAR THE POINT OF OPERATION.

## FOR SINGLE PHASE



## FOR THREE PHASE

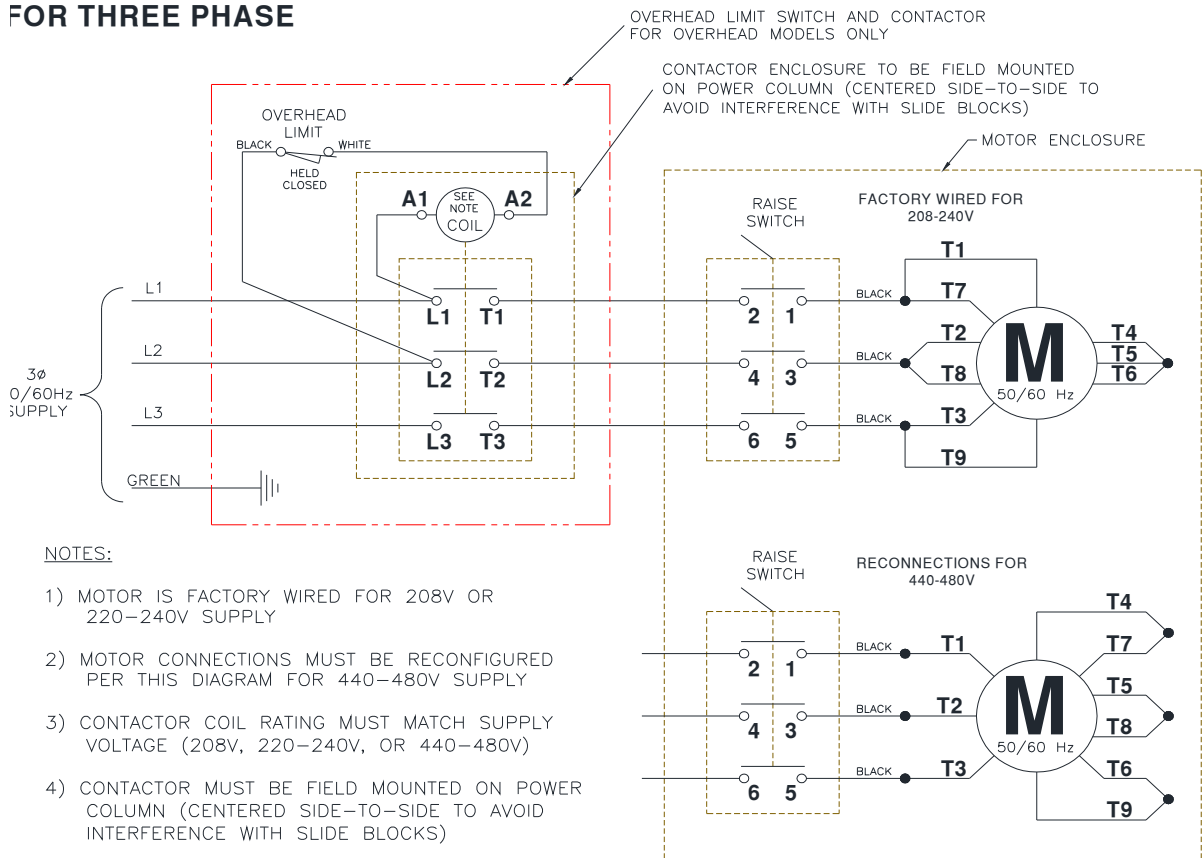


Fig 22 – Electrical Wiring Diagram

## **OPERATION PROCEDURE**

### **SAFETY NOTICES AND DECALS**

This product is furnished with graphic safety warning labels, which are reproduced on page 3 of these instructions. Do not remove or deface these warning labels, or allow them to be removed or defaced. For your safety, and the safety of others, read and understand all of the safety notices and decals included.

### **OWNER/EMPLOYER RESPONSIBILITIES**

This lift has been designed and constructed according to ANSI/ALI ALCTV-2011 standard. The standard applies to lift manufactures, as well as to owners and employers. The owner/employer's responsibilities as prescribed by ANSI/ALI ALOIM-2008, are summarized below. For exact wording refer to the actual standard provided with this manual in the literature pack.

**The Owner/Employer shall** insure that lift operators are qualified and that they are trained in the safe use and operation of the lift using the manufacturer's operating instructions; ALI/SM 93 -1, ALI Lifting it Right safety manual; ALI/ST-90 ALI Safety Tips card; ANSI/ALI ALOIM-2008, American National Standard for Automotive Lifts-Safety Requirements for Operation, Inspection and Maintenance; ALI/WL Series, ALI Uniform Warning Label Decals/Placards; and in case of frame engaging lifts, ALI/LP-GUIDE, Vehicle Lifting Points/Quick Reference Guide for Frame Engaging Lifts.

**The Owner/Employer shall** establish procedures to periodically inspect the lift in accordance with the lift manufacturer's instructions or ANSI/ALI ALOIM-2008, American National Standard for Automotive Lifts-Safety Requirements for Operation, Inspection and Maintenance; and the employer shall insure that the lift inspectors are qualified and that they are adequately trained in the inspection of the lift.

**The Owner/Employer shall** establish procedures to periodically maintain the lift in accordance with the lift manufacturer's instructions or ANSI/ALIOIM-2008, American National Standard for Automotive Lifts-Safety Requirements for Operation, Inspection and Maintenance; and the employer shall insure that the lift maintenance personnel are qualified and that they are adequately trained in the maintenance of the lift.

**The Owner/Employer shall** maintain the periodic inspection and maintenance records recommended by the manufacturer or ANSI/ALI ALOIM-2008, American National Standard for Automotive Lifts-Safety Requirements for Operation, Inspection and Maintenance.

**The Owner/Employer shall** display the lift manufacturer's operating instructions; ALI/SM

93 -1, ALI Lifting it Right safety manual; ALI/ST-90 ALI Safety Tips card; ANSI/ALI ALOIM-2008, American National Standard for Automotive Lifts-Safety Requirements for Operation, Inspection and Maintenance; and in the case of frame engaging lift, ALI/LP-GUIDE, Vehicle Lifting Points/Quick Reference Guide for Frame Engaging Lifts; in a conspicuous location in the lift area convenient to the operator.

### **IMPORTANT SAFETY INSTRUCTIONS**

When using your garage equipment, basic safety precautions should always be followed, including the following:

1. Read all instructions.
2. Care must be taken as burns can occur from touching hot parts.
3. To reduce the risk of fire, do not operate equipment in the vicinity of open containers of flammable liquids (gasoline).
4. Keep hair, loose clothing, fingers, and all parts of body away from moving parts.
5. Use only as described in this manual. Use only manufacturer's recommended attachments.
6. ALWAYS WEAR SAFETY GLASSES. Everyday eyeglasses only have impact resistant lenses, they are not safety glasses.

## **LIFTING A VEHICLE**

- 1) Ensure that the lifting arms are parked, out to full drive thru position.
- 2) Center the vehicle between the columns in the service bay and position the vehicle's center of gravity midpoint between the columns. **NOTE: the center of gravity is based on the weight distribution and is not the same as the center point of the vehicle.**

**DO NOT EXCEED 2500 POUNDS PER ARM.**

**DO NOT ATTEMPT TO LIFT THE VEHICLE WITH ONLY TWO ARMS, AS THIS WILL VOID THE WARRANTY**

**INSURE THAT THE HIGHEST POINT ON THE VEHICLE WILL CONTACT THE OVERHEAD LIMIT SWITCH BAR.**

**DO NOT PLACE THE VEHICLE IN THE SERVICE BAY BACKWARDS.**

**REFER TO THE VEHICLE MANUFACTURERS SERVICE MANUAL, TECHNICAL BULLETINS, "VEHICLE LIFTING POINTS GUIDE" (ALI/LP-GUIDE) OR OTHER PUBLICATIONS TO LOCATE THE RECOMMENDED LIFTING POINTS.**

- 3) Position the arms and adapters so all four pads contact the vehicle simultaneously.

**The vehicle should remain level during lifting.**

- 4) Raise the lift until all four wheels are off the ground. Test the stability of the vehicle by attempting to rock the vehicle. Check adapters for secure contact with vehicle lift points. If the vehicle seems unstable, lower the lift and readjust the arms. If the vehicle is stable, raise the vehicle to a height a few inches above the desired working height.
- 5) Lower the vehicle until the safety locks on both columns engage. The vehicle should remain level when both locks are engaged. If one side engages and the other continues to descend, stop lowering the vehicle, raise it several inches, and try to engage both locks.

**Always lower lift into locks before entering the area beneath the vehicle.**

**Always use safety stands when removing or installing heavy components.**

## **LOWERING A VEHICLE**

- 1) Insure that the area under the vehicle is clear of personnel and tools.
- 2) Raise the vehicle until both latches are free.
- 3) Disengage the locks by pulling and holding the lock release lever.
- 4) Lower the vehicle by depressing the lowering valve handle.
- 5) Continue to lower the vehicle until the carriages stop against the base plate. Retract the extension arms, and park them.

## **LOSS OF POWER**

If for any reason the lift will not raise off the locks or the locks will not retract, consult factory authorized personnel.

**DO NOT OVERRIDE ANY SAFETY FEATURE IN AN ATTEMPT TO LOWER THE LIFT.**

## **MAINTENANCE**

To avoid personal injury, permit only qualified personnel to perform maintenance on this equipment. Maintenance personnel should follow lockout/tagout instructions per ANSI Z244.1.

The following maintenance points are suggested as the basis of a routine maintenance program. The actual maintenance program should be tailored to the installation. See ANSI/ALI ALOIM booklet for periodic inspection checklist and maintenance log sheet.

- If lift stops short of full rise or chatters, check fluid level and bleed both cylinders per Installation Instructions.
- Replace all Safety, Warning or Caution Labels if missing or damaged (**See Installation instructions page 3.**)

### **Daily**

- Keep lift components clean.
- Check for loose or broken parts.
- Check hydraulic system for fluid leaks.
- Check adapters for damage or excessive wear. Replace as required with genuine Challenger Lifts parts.
- Check lock release activation. When properly adjusted, the idler column lock should rest firmly against the back of the column when engaged.

### **Weekly**

- Check synchronizer cables and sheaves for wear. Replace as required with genuine Challenger Lifts parts.
- Check synchronizer cable tension per Installation Instructions. Adjust if necessary.

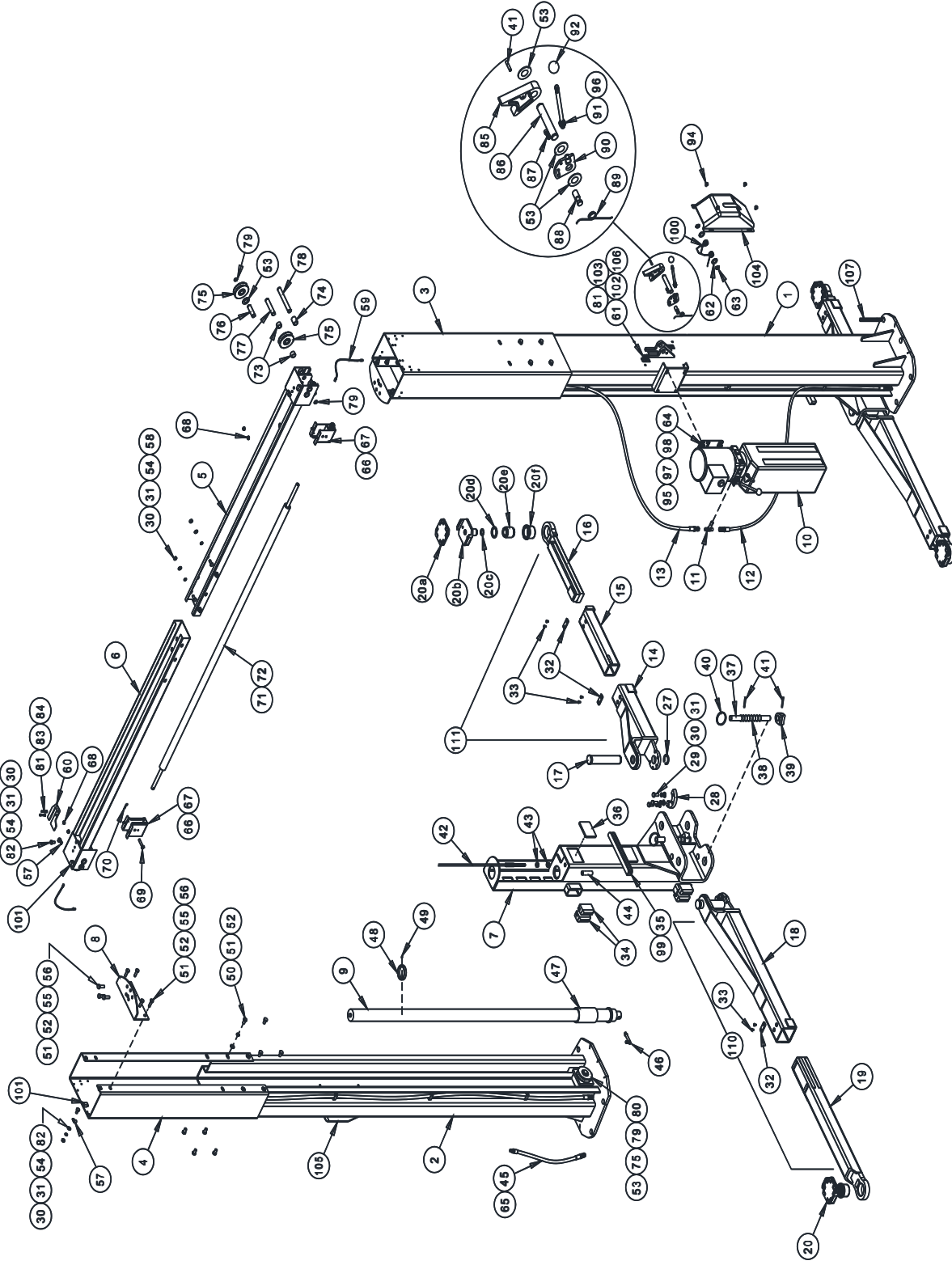
### **Monthly**

- Torque concrete anchor bolts to 80 ft-lbs.
- Visually inspect concrete floor for cracks and/or spawls within 12" of base plate
- Check overhead shutoff switch. While raising lift, operate overhead shutoff bar. Power Unit motor should stop when bar is raised.
- Lubricate carriage slide tracks with heavy viscous grease. (Grease all (4) corners of both columns.)
- Visually inspect concrete floor for cracks and/or spawls within 12" of base plate

**If any problems are encountered, contact your local service representative.**

**If any problems are encountered, contact your local Challenger Service Representative.**

Model SA10  
Installation, Operation and Maintenance  
**PARTS BREAKDOWN**



**IMPORTANT**

Replace worn, damaged, or broken parts with parts approved by **Challenger Lifts, Inc.** or with parts meeting **Challenger Lifts Inc.** specifications. Contact a local Challenger Lifts parts distributor for pricing and availability. Call **Challenger Lifts Inc.** at (502) 625-0700 for the distributor in your area.



Model SA10  
Installation, Operation and Maintenance

Item #	Part #	Qty.	Description
1	3W-01P	1	Power Column Weld
2	3W-01I	1	Idle Column Weld
3	3W-01-05PA	1	Power Col. Extension (Std. Height)
	3W-01-25PA		Power Col. Extension (2Ft. Ext. Height)
4	3W-01-05IA	1	Idle Col. Extension (Std. Height)
	3W-01-25IA		Idle Col. Extension (2Ft. Ext. Height)
5	3W-03PA	1	Power Overhead Weld
6	3W-03IA	1	Idle Overhead Weld
7	3W-02A	2	Carriage Weld
8	3W-03-07	2	Overhead Mounting Bracket
9	16138R	2	Cylinder
10	AB-9367-DLH	1	Power Unit
11	3W-06-15A	1	Tee Fitting
12	3W-06-06A	1	Power Hose Assembly
13	3W-06-07A	1	Idle Hose Assembly
14	3W-04-20A	2	Front Female Arm Weld
15	3W-04-23	2	Front Intermediate Weld
16	3W-04-28	2	Front Male Weld
17	3W-02-12	4	Arm Pin
18	3W-04-02A	2	Rear Female Weld
19	3W-04-09A	2	Rear Male Weld
20	B2270	4	Foot Pad Assembly
	A1104-H		Rubber Insert
20b	A1101-1H	1	Foot Pad Weld
20c	B17256	1	2 dia. x 30mm Retaining Ring
20d	B17257	2	3 dia. x 45mm Retaining Ring
20e	B2261	1	Threaded Sleeve
20f	B17276-1	1	Threaded Insert
27	3W-06-01	4	Arm Pin Retaining Ring
28	3W-04-17	4	Inner Arm Restraint Gear

Item #	Part #	Qty.	Description
29	HEXHM1030	12	M10 x 30 Hex Bolt
30	X10-073	20	M10 Flat Washer
31	B31037	20	M10 Spring Lock Washer
32	3W-04-18	6	Arm Stop Insert
33	3W-10-10	12	M8 x 14 Flat Head Allen Bolt, 10.9
34	3W-02-11A	16	Carriage Slide Block
35	3W-06-03	2	Rubber Bumper Insert
36	3W-06-16	4	Access Cover
37	3W-02-14	4	Arm Restraint Gear Shaft
38	3W-02-15	4	Arm Restraint Shaft Spring
39	3W-02-13	4	Outer Arm Restraint Gear
40	3W-02-16	4	Pull Ring
41	3W-10-01	10	M6 x 40 Roll Pin
42	3W-06-08A	2	Synchronization Cable (Std. Height)
	3W-06-28A		Synchronization Cable (2Ft. Ext. Height)
43	HJNM12	8	M12 Hex Jam Nut
44	3W-06-18	1	Cable Spacer (Asymmetric Only)
45	3W-06-05A	1	Hose Extension (Std. Height)
	3W-06-25A		Hose Extension (2Ft. Ext. Height)
46	3W-06-14A	2	Cylinder Elbow Fitting
47	3W-02-18	2	Cylinder Sleeve
48	3W-02-19	2	Cylinder Clamp Ring
49	3W-10-02	2	M6 x 10mm Set Screw
50	17314	16	M12 x 20 Hex Bolt
51	X10-038	30	M12 Flat Washer
52	X10-039	30	M12 Spring Lock Washer
53	3W-10-07	10	M20 x 1.5 thk. Round Shim
54	HNM10	8	M10 Hex Nut
55	VS10-40-13	14	M12 x 25 Hex Bolt
56	HNM12	14	M12 Hex Nut

Model SA10  
Installation, Operation and Maintenance

Item #	Part #	Qty.	Description
57	3W-10-15A	4	Hose Clamp
58	MR6-002	6	M10 x 20 Hex Bolt
59	3W-01-20	2	Flexible Guide Tube
60	3W-03-18A	2	Cable Trap Plate
61	3W-06-19	1	Lock Release Cable Clamp
62	X10-099	4	20mm Flat Washer
63	X10-020	4	20mm External Snap Ring
64	VS10-10-26	4	M8 Flat Washer
65	3W-06-04	1	Hose Extension Connector
66	B2064-01	1	Limit Switch Package (incl. 67-70)
67	B2065-3	4	M6 x 14mm Screw
68	B2065-4	4	M6 Serrated Flange Hex Nut
69	B2065-5	1	M10 x 55 Clevis Pin
70	GJY12-3	1	Hairpin Cotter Pin
71	A2067	1	Shutoff Bar
72	31129	1	Shutoff Bar Cushion
73	3W-03-09B	4	17mm Sheave Spacer (Asymmetric Only)
74	3W-03-09	2	34mm Sheave Spacer (Symmetric Only)
75	3W-01-04-03	6	Cable Sheave
76	3W-03-12	2	Short Sheave Pin (Asymmetric Only)
77	3W-03-11	2	Medium Sheave Pin (Asymmetric Only)
78	3W-03-10	2	Long Sheave Pin (Symmetric Only)
79	SR-0121	10	M19 Snap Ring
80	3W-01-04-05	2	Sheave Retaining Bolt
81	Q4P09-007	5	M6 x 12 Hex Bolt
82	HEXM1025	4	M10 x 25 Hex Bolt
83	X10-032	4	M6 Flat Washer

**IMPORTANT**

Replace worn, damaged, or broken parts with parts approved by **Challenger Lifts, Inc.** or with parts meeting **Challenger Lifts Inc.** specifications.  
Contact a local Challenger Lifts parts distributor for pricing and availability. Call **Challenger Lifts Inc.** at (502) 625-0700 for the distributor in your area.

Item #	Part #	Qty.	Description
84	X10-033	4	M6 Lock Washer
85	3W-01-08	2	Lock Paw
86	3W-01-14	2	Lock Clevis Pin
87	QRJ9-41	2	M6 x 20 Socket Head Cap Screw
88	3W-01-16	2	Lock Release Cam Pin
89	3W-01-06A	2	Lock Spring (Cam)
90	3W-01-19	2	Lock Release Cam
91	3W-01-17	1	Lock Release Lever
92	3W-01-22	1	Knob
94	VS10-10-25	8	M8 x 8 Phillips Pan Head Screw
95	MR6-008	4	M8 Spring Lock Washer
96	HJNM10	1	M10 Hex Jam Nut
97	X10-088	4	M8 x 30 Hex Bolt
98	HEXNM8	5	M8 Hex Nut
99	Q4P09-006	2	M8 x 20 Socket Head Cap Screw
100	3W-01-13A	2	Lock Spring (Paw)
101	3W-01-23	4	Lock Block Sleeve Insert
102	3W-06-11A	1	Lock Release Cable (Std. Height)
	3W-06-31A		Lock Release Cable (2Ft. Ext. Height)
103	VS10-10-27	2	M9 Snap Ring
104	3W-01-11-01	1	Power Lock Cover
105	3W-01-11-02	1	Idler Lock Cover
106	3W-01-18	2	Lock Pulley
107	31058	10	Anchor Bolt, 3/4 x 5-1/2" Lg
110	3W-04-01A	2	Rear Arm Assy (w/o footpad & pin)
111	3W-04-19A	2	Front Arm Assy (w/o footpad & pin)

## **REVISIONS**

- 11/19/2019- UPDATED MISSING CONNECTION IN ELECTRICAL DIAGRAM. UPDATED SAFETY REQUIREMENTS FOR INSTALLATION AND SERVICE. ADDED STEP TO CHECK THE ARM STOP BOLTS TO MAKE SURE THEY ARE TIGHT.
- 02/14/2020-20mm FLAT WASHERS WERE ADDED TO THE LOCK CLEVIS PIN TO HELP KEEP THE SPRINGS ON THE PIN. THE 20mm EXTERNAL SNAP RINGS WERE MISSING FROM THE PARTS BREAKDOWN AND WERE ADDED.